



U. S. Department of Transportation
Federal Highway Administration

Publication No. FHWA-NHI-10-024
FHWA GEC 011 – Volume I
November 2009

NHI Courses No. 132042 and 132043

Design and Construction of Mechanically Stabilized Earth Walls and Reinforced Soil Slopes – Volume I

Developed following:

*AASHTO LRFD Bridge Design
Specifications, 4th Edition, 2007,
with 2008 and 2009 Interims.*

and

*AASHTO LRFD Bridge Construction
Specifications, 2nd Edition, 2004, with
2006, 2007, 2008, and 2009 Interims.*



NOTICE

The contents of this report reflect the views of the authors, who are responsible for the facts and accuracy of the data presented herein. The contents do not necessarily reflect policy of the Department of Transportation. This report does not constitute a standard, specification, or regulation. The United States Government does not endorse products or manufacturers. Trade or manufacturer's names appear herein only because they are considered essential to the object of this document.

Technical Report Documentation Page

1. REPORT NO. FHWA-NHI-10-024 FHWA GEC 011-Vol I	2. GOVERNMENT ACCESSION NO.	3. RECIPIENT'S CATALOG NO.	
4. TITLE AND SUBTITLE Design of Mechanically Stabilized Earth Walls and Reinforced Soil Slopes – Volume I	5. REPORT DATE November 2009		
	6. PERFORMING ORGANIZATION CODE		
7. AUTHOR(S) Ryan R. Berg, P.E.; Barry R. Christopher, Ph.D., P.E. and Naresh C. Samtani, Ph.D., P.E.	8. PERFORMING ORGANIZATION REPORT NO.		
9. PERFORMING ORGANIZATION NAME AND ADDRESS Ryan R. Berg & Associates, Inc. 2190 Leyland Alcove Woodbury, MN 55125	10. WORK UNIT NO.		
	11. CONTRACT OR GRANT NO. DTFH61-06-D-00019/T-06-001		
12. SPONSORING AGENCY NAME AND ADDRESS National Highway Institute Federal Highway Administration U.S. Department of Transportation Washington, D.C.	13. TYPE OF REPORT & PERIOD COVERED		
	14. SPONSORING AGENCY CODE		
15. SUPPLEMENTARY NOTES FHWA Technical Consultants: Rich Barrows, P.E., Silas Nichols, P.E., and Daniel Alzamora, P.E. Technical Consultant: James G. Collin, Ph.D., P.E.			
16. ABSTRACT <p>This manual is the reference text used for the FHWA NHI courses No. 132042 and 132043 on Mechanically Stabilized Earth Walls and Reinforced Soil Slopes and reflects current practice for the design, construction and monitoring of these structures. This manual was prepared to enable the engineer to identify and evaluate potential applications of MSE walls and RSS as an alternative to other construction methods and as a means to solve construction problems. The scope is sufficiently broad to be of value for specifications specialists, construction and contracting personnel responsible for construction inspection, development of material specifications and contracting methods. With the aid of this text, the engineer should be able to properly select, design, specify, monitor and contract for the construction of MSE walls and RSS embankments.</p> <p>The MSE wall design within this manual is based upon Load and Resistance Factor Design (LRFD) procedures. This manual is a revision (to LRFD) and an update to the FHWA NHI-00-043 manual (which was based upon allowable stress design (ASD) procedures).</p>			
17. KEY WORDS Design, Load and Resistance Factor Design (LRFD), analysis, performance criteria, Mechanically Stabilized Earth (MSE) Walls, Reinforced Soil Slopes (RSS), soil reinforcement, geosynthetics, specifications, contracting methods		18. DISTRIBUTION STATEMENT No restrictions.	
19. SECURITY CLASSIF. Unclassified	20. SECURITY CLASSIF. Unclassified	21. NO. OF PAGES 306	22

SI CONVERSION FACTORS				
APPROXIMATE CONVERSIONS FROM SI UNITS				
Symbol	When You Know	Multiply By	To Find	Symbol
LENGTH				
mm	millimeters	0.039	inches	in
m	meters	3.28	feet	ft
m	meters	1.09	yards	yd
km	kilometers	0.621	miles	mi
AREA				
mm ²	square millimeters	0.0016	square inches	in ²
m ²	square meters	10.764	square feet	ft ²
m ²	square meters	1.195	square yards	yd ²
ha	hectares	2.47	acres	ac
km ²	square kilometers	0.386	square miles	mi ²
VOLUME				
ml	milliliters	0.034	fluid ounces	fl oz
l	liters	0.264	gallons	gal
m ³	cubic meters	35.71	cubic feet	ft ³
m ³	cubic meters	1.307	cubic yards	yd ³
MASS				
g	grams	0.035	ounces	oz
kg	kilograms	2.202	pounds	lb
TEMPERATURE				
°C	Celsius	1.8 C + 32	Fahrenheit	°F
WEIGHT DENSITY				
kN/m ³	kilonewton / cubic m	6.36	poundforce / cubic foot	pcf
FORCE and PRESSURE or STRESS				
N	newtons	0.225	poundforce	lbf
kN	kilonewtons	225	poundforce	lbf
kPa	kilopascals	0.145	poundforce / sq in.	psi
kPa	kilopascals	20.9	poundforce / sq ft	psf

PREFACE

Engineers and specialty material suppliers have been designing reinforced soil structures for the past 35 years. Currently, many state DOTs are transitioning their design of substructures from Allowable Stress Design (ASD) to Load and Resistance Factor Design (LRFD) procedures.

This manual is based upon LRFD for MSE wall structures. It has been updated from the 2001 FHWA NHI-00-043 manual. In addition to revision of the wall design to LRFD procedures, expanded discussion on wall detailing and general updates throughout the manual are provided. The primary purpose of this manual is to support educational programs conducted by FHWA for transportation agencies.

A second purpose of equal importance is to serve as the FHWA standard reference for highway projects involving MSE wall and reinforced soil structures.

This Mechanically Stabilized Earth Walls (MSE) and Reinforced Soil Slopes (RSS), Design and Construction Guidelines Manual which is an update of the current FHWA NHI-00-043, has evolved from the following AASHTO and FHWA references:

- AASHTO LRFD Bridge Design Specifications, 4th Edition, 2007, with 2008 and 2009 Interim Revisions.
- *Earth Retaining Structures*, by B.F. Tanyu, P.J. Sabatini, and R.R. Berg, FHWA-NHI-07-071 (2008).
- AASHTO LRFD Bridge Construction Specifications, 2nd Edition, 2004, with 2006 Interim Revisions.
- *Geosynthetic Design and Construction Guidelines*, by R.D. Holtz, B.R. Christopher, and R.R. Berg, FHWA HI-07-092 (2008).
- *Guidelines for Design, Specification, and Contracting of Geosynthetic Mechanically Stabilized Earth Slopes on Firm Foundations*, by R.R. Berg, FHWA-SA-93-025, January 1993.
- *Reinforced Soil Structures - Volume I, Design and Construction Guidelines - Volume II, Summary of Research and Systems Information*, by B.R. Christopher, S.A. Gill, J.P. Giroud, J.K. Mitchell, F. Schlosser, and J. Dunncliff, FHWA RD 89-043 (1990).
- *Design and Construction Monitoring of Mechanically Stabilized Earth Structures*, by J.A. DiMaggio, FHWA, (1994).
- AASHTO Bridge T-15 Technical Committee unpublished working drafts for the update of Section 11.0 of the AASHTO LRFD Bridge Design Specifications.

The authors recognize the efforts and contributions of Messrs. Richard Barrows, P.E., Silas Nichols, P.E., and Daniel Alzamora P.E. who were the FHWA Technical Consultants for this work.

The authors also recognize the contributions of the other Technical Consultants on this project. They are:

- Tony Allen, P.E. of Washington DOT
- Christopher Benda, P.E. of Vermont DOT
- James Brennan, P.E. of Kansas DOT
- James Collin, Ph.D., P.E. of The Collin Group
- Jerry DiMaggio, P.E. of the National Academy of Sciences
- Kenneth L. Fishman, Ph.D., P.E. of Earth Reinforcement Testing, Inc.
- Kathryn Griswell, P.E. of CALTRANS
- John Guido, P.E. of Ohio DOT
- Dan Johnston, P.E. of South Dakota DOT
- Dov Leshchinsky, Ph.D. of the University of Delaware
- Michael Simac, P.E. of Earth Improvement Technologies, Inc.
- James L. Withiam, Ph.D., P.E. of D'Appolonia Engineers

And the authors acknowledge the contributions of the following industry associations:

- Association of Metallically Stabilized Earth (AMSE)
- Geosynthetic Materials Association (GMA)
- National Concrete Masonry Association (NCMA)

A special acknowledgement of Mr. Jerry A. DiMaggio, P.E. who was the FHWA Technical Consultant for most of the above referenced publications. Mr. DiMaggio's guidance and input to this and the previous works has been invaluable.

Lastly, the authors wish to acknowledge the extensive work of the late Victor Elias, P.E. for his vital contributions and significant effort as Lead Author in preparing the earlier two (1997, 2001) versions of this manual, and as the author of the earlier companion manuals on corrosion/degradation of soil reinforcements. Mr. Elias was instrumental in the introduction and implementation of reinforced soil technology in the U.S., as a Vice President for The Reinforced Earth Company from 1974 to 1985. He was instrumental in research, refinement of design methods, and standards of practice and codes for MSE walls, as a Consultant from 1985 until 2006.

TABLE OF CONTENTS – Volume I

CHAPTER 1 INTRODUCTION	1-1
1.1 OBJECTIVES	1-1
1.1.1 Scope	1-1
1.1.2 Source Documents	1-2
1.1.3 Terminology.....	1-3
1.2 HISTORICAL DEVELOPMENT	1-4
1.3 LOAD AND RESISTANCE FACTOR DESIGN (LRFD)	1-12
CHAPTER 2 SYSTEMS AND PROJECT EVALUATION.....	2-1
2.1 APPLICATIONS	2-1
2.1.1 MSE Walls.....	2-1
2.1.2 Reinforced Soil Slopes.....	2-4
2.2 ADVANTAGES AND POTENTIAL DISADVANTAGES.....	2-6
2.2.1 Advantages of Mechanically Stabilized Earth (MSE) Walls.....	2-6
2.2.2 Advantages of Reinforced Soil Slopes (RSS).....	2-6
2.2.3 Potential Disadvantages	2-7
2.3 RELATIVE COSTS.....	2-7
2.4 DESCRIPTION OF MSE/RSS SYSTEMS	2-10
2.4.1 Systems Differentiation	2-10
2.4.2 Types of Systems	2-11
2.4.3 Facing Systems	2-12
2.4.4 Reinforcement Types.....	2-16
2.4.5 Reinforced Fill Materials	2-17
2.4.6 Appurtenant Materials of Construction	2-18
2.5 CONSTRUCTION SEQUENCE.....	2-18
2.5.1 Construction of MSEW systems with precast facings.....	2-18
2.5.2 Construction of MSE systems with Flexible Facings.....	2-24
2.5.3 RSS Construction.....	2-28
2.6 SITE EVALUATION	2-28
2.6.1 Site Exploration	2-28
2.6.2 Field Reconnaissance.....	2-30
2.6.3 Subsurface Exploration.....	2-30
2.6.4 Laboratory Testing.....	2-32
2.6.5 Foundation Soils	2-33
2.7 PROJECT EVALUATION.....	2-34
2.7.1 Structure Selection Factors	2-34
2.7.2 Geologic and Topographic Conditions	2-35
2.7.3 Environmental Conditions	2-36
2.7.4 Size and Nature of Structure	2-37
2.7.5 Aesthetics.....	2-38
2.7.6 Questionable Applications.....	2-38
2.8 ESTABLISHMENT OF PROJECT CRITERIA	2-38
2.8.1 Alternates	2-39
2.8.2 Facing Considerations.....	2-39

2.8.3	Performance Criteria.....	2-40
2.8.4	Design Life.....	2-46
2.9	PROPRIETARY ASPECTS.....	2-46
2.10	CASE HISTORIES -- MSE WALLS.....	2-47
2.10.1	Mn/DOT Crosstown Project MSE Walls.....	2-47
2.10.2	Veterans Memorial Overpass True Abutment MSE Walls.....	2-49
2.10.3	SEATAC Runway Extension Wall.....	2-50
2.10.4	Guanella Pass Roadway Reconstruction.....	2-51

CHAPTER 3 SOIL REINFORCEMENT PRINCIPLES

	AND SYSTEM DESIGN PROPERTIES.....	3-1
3.1	OVERVIEW.....	3-1
3.2	ESTABLISHMENT OF ENGINEERING PROPERTIES BASED ON SITE EXPLORATION AND TESTING.....	3-2
3.2.1	Reinforced Fill Soil.....	3-2
3.2.2	Retained Backfill and Natural Retained Soil.....	3-8
3.2.3	Electrochemical Properties.....	3-9
3.3	REINFORCED SOIL CONCEPTS.....	3-10
3.3.1	Stress Transfer Mechanisms.....	3-10
3.3.2	Mode of Reinforcement Action.....	3-12
3.3.3	Geometric Characteristics.....	3-12
3.4	SOIL REINFORCEMENT INTERACTION USING NORMALIZED CONCEPTS.....	3-13
3.4.1	Evaluation of Pullout Performance.....	3-13
3.4.2	Estimate of the Reinforcement Pullout Capacity in MSE Structures.....	3-16
3.4.3	Interface Shear.....	3-21
3.5	ESTABLISHMENT OF STRUCTURAL DESIGN PROPERTIES.....	3-22
3.5.1	Strength Properties of Steel Reinforcements.....	3-22
3.5.2	Strength Properties of Geosynthetic Reinforcement.....	3-28
3.5.2.a	Ultimate Tensile Strength, T_{ult}	3-31
3.5.2.b	Installation Damage Reduction Factor, RF_{ID}	3-31
3.5.2.c	Creep Reduction Factor, RF_{CR}	3-32
3.5.2.d	Durability Reduction Factor, RF_D	3-33
3.5.2.e	Durability Reduction Factor, RF_D , at Wall Face Unit.....	3-38
3.5.2.f	LRFD Geosynthetic Resistance Factor, ϕ	3-38
3.5.2.g	Preliminary Design Reduction Factor, RF	3-39
3.5.2.h	Serviceability Limit State.....	3-40
3.6	FACING MATERIALS.....	3-41
3.6.1	Precast Concrete Panels.....	3-41
3.6.1.a	Segmental Panels.....	3-41
3.6.1.b	Full-Height Panels.....	3-42
3.6.2	Modular Block Wall (MBW) Units.....	3-43
3.6.3	Welded Wire Mesh Facing.....	3-46
3.6.4	Geosynthetic Wrap-Around Facing.....	3-47
3.6.5	Other Facings.....	3-47
3.6.6	Two-Stage Facings.....	3-50

CHAPTER 4 DESIGN OF MSE WALLS	4-1
4.1 DESIGN METHODOLOGY AND ANALYSIS METHODS	4-1
4.1.1 Load and Resistance Factor Design (LRFD) Platform	4-1
4.1.2 Analysis Methods.....	4-2
4.2 LOADS AND LOAD COMBINATIONS.....	4-3
4.3 DESIGN OF MSE WALLS USING LRFD METHODOLOGY	4-6
4.3.1 Design Steps.....	4-7
4.4 MSE WALLS DESIGN GUIDELINES	4-9
4.4.1 Step 1 - Establish Project Requirements	4-9
4.4.2 Step 2 - Establish Project Parameters	4-9
4.4.3 Step 3 - Estimate Wall Embedment Depth & Reinforcement Length ...	4-10
4.4.4 Step 4 - Define Nominal Loads	4-11
4.4.5 Step 5 - Summarize Load Combinations, Load Factors, and Resistance Factors	4-17
4.4.6 Step 6 - Evaluate External Stability	4-18
4.4.6.a Evaluate Sliding Stability	4-19
4.4.6.b Evaluate Eccentricity	4-22
4.4.6.c Evaluate Bearing on Foundation.....	4-26
4.4.6.d Settlement Estimate	4-31
4.4.7 Step 7 - Evaluate Internal Stability	4-31
4.4.7.a Select Type of Reinforcement	4-32
4.4.7.b Define Critical Slip Surface	4-33
4.4.7.c Define Unfactored Loads.....	4-35
4.4.7.d Establish Vertical Layout of Soil Reinforcements.....	4-38
4.4.7.e Calculate Factored Tensile Forces in Reinforcements.....	4-39
4.4.7.f Calculate Soil Reinforcement Resistance	4-47
4.4.7.g Select Grade of &/or Number of Elements at Each Level.....	4-49
4.4.7.h Internal Stability with Respect to Pullout Failure.....	4-49
4.4.7.i Check Connection Strength	4-52
4.4.7.j Lateral Movements	4-57
4.4.7.k Vertical Movement and Bearing Pads	4-57
4.4.8 Step 8 - Design of Facing Elements.....	4-58
4.4.8.a Design of Concrete, Steel, and Timber Facings	4-58
4.4.8.b Design of Flexible Wall Facings.....	4-59
4.4.9 Step 9 - Assess Overall Stability.....	4-59
4.4.10 Step 10 - Assess Compound Stability.....	4-61
4.4.11 Step 11 - Wall Drainage Systems	4-65
4.11.a Surface Drainage.....	4-65
4.11.b Surface Water Runoff	4-65
4.11.c Scour	4-65
4.5 TEMPORARY WALLS	4-66
4.6 DESIGN CHECKLIST	4-66
4.7 COMPUTER-AIDED DESIGN	4-80
4.8 VENDOR	4-80
4.9 STANDARD MSEW DESIGNS	4-80

CHAPTER 5 MSE WALL DESIGN DETAILS	5-1
5.1 TOP OF WALL ELEMENTS	5-1
5.1.1 Copings	5-1
5.1.2 Traffic Barriers.....	5-4
5.1.3 Parapets.....	5-4
5.1.4 Post and Beam Barriers.....	5-4
5.1.5 Drainage Related to Top of Wall Elements	5-6
5.2 BOTTOM OF WALL ELEMENTS	5-6
5.3 DRAINAGE.....	5-8
5.3.1 Internal Drainage Systems	5-9
5.3.2 External Drainage	5-17
5.3.3 Filtration and Drainage System Component Requirements.....	5-24
5.3.4 Maintenance of Drainage.....	5-34
5.4 INTERNAL DETAILS.....	5-35
5.4.1 Contact Between Dissimilar Metals.....	5-35
5.4.2 Vertical Obstructions in Reinforced Soil Mass	5-35
5.4.3 Horizontal Obstructions in Reinforced Soil Mass	5-42
5.4.4 Wall Face Penetrations	5-44
5.4.5 Slip Joints.....	5-46
5.4.6 Wall Curves	5-47
5.4.7 Wall Corners	5-51
5.4.8 Two-Stage Facing.....	5-52
5.5 WALL INITIATIONS AND TERMINATIONS	5-54
5.6 AESTHETICS.....	5-56
CHAPTER 6 DESIGN OF MSE WALLS WITH COMPLEX GEOMETRICS	6-1
6.1 BRIDGE ABUTMENTS	6-3
6.1.1 MSEW Abutments on Spread Footings.....	6-3
6.1.2 MSEW Abutments on Stub Footings Supported by Deep Foundations through Reinforced Wall Fill	6-6
6.1.3 Alternative Configuration of MSE Walls at Bridge Abutments.....	6-10
6.1.4 Protection of MSE Wall at Abutments	6-11
6.2 SUPERIMPOSED (TIERED) MSE WALLS.....	6-13
6.2.1 2-Tier Superimposed Wall.....	6-13
6.2.2 Superimposed Walls with More than 2-Tiers	6-15
6.3 WALLS WITH UNEVEN REINFORCEMENT LENGTHS	6-16
6.4 BACK-TO-BACK (BBMSE) WALLS	6-17
6.5 SHORED MSE WALLS FOR STEEP TERRAINS AND LOW VOLUME ROADS.....	6-19
6.6 STABLE FEATURE MSE (SFMSE) WALLS	6-26
CHAPTER 7 DESIGN OF MSE WALLS FOR EXTREME EVENTS.....	7-1
7.1 SEISMIC EVENTS	7-1
7.1.1 External Stability	7-1
7.1.2 Internal Stability.....	7-9
7.1.2.a Tensile Failure	7-11
7.1.2.b Pullout Failure.....	7-12

	7.1.3 Facing Reinforcement Connections.....	7-13
7.2	VEHICULAR IMPACT EVENTS.....	7-14
	7.2.1 Traffic Barriers.....	7-15
	7.2.2 Post and Beam Railings.....	7-17
7.3	FLOODS AND SCOUR.....	7-18

LIST OF TABLES – Volume I

Table 1-1.	Summary of Reinforcement and Face Details for MSE Wall Systems.	1-7
Table 1-2.	Representative List of Geogrid and Geotextile Reinforcement Manufacturers and Suppliers.....	1-11
Table 2-1.	Typical Minimum Length of Reinforcement.....	2-43
Table 2-2.	Minimum MSEW Embedment Depths.....	2-43
Table 2-3.	Relationship Between Joint Width and Limiting Differential Settlements for MSE Precast Panels.....	2-46
Table 3-1.	MSE Wall Select Granular Reinforced Fill Requirements.....	3-3
Table 3-2.	RSS Granular Reinforced Fill Requirements.....	3-6
Table 3-3.	Recommended Limits of Electrochemical Properties for Reinforced Fills with Steel Reinforcement.....	3-9
Table 3-4.	Recommended Limits of Electrochemical Properties for Reinforced Fills with Geosynthetic Reinforcements.....	3-10
Table 3-5.	Basic Aspects of Reinforcement Pullout Performance in Granular and Cohesive Soils of Low Plasticity.....	3-15
Table 3-6.	Summary of Pullout Capacity Design Parameters.....	3-17
Table 3-7.	Minimum Galvanization Thickness by Steel Thickness.....	3-26
Table 3-8.	Steel Corrosion Rates for Mildly Corrosive Reinforced Fill.....	3-26
Table 3-9.	Installation Damage Reduction Factors.....	3-32
Table 3-10.	Anticipated Resistance of Polymers to Specific Environments.....	3-34
Table 3-11.	Durability (Aging) Reduction Factors for PET.....	3-36
Table 3-12.	Minimum Requirements for use of Default Durability Reduction Factors (RF _D) for Primary Geosynthetic Reinforcement.....	3-37
Table 3-13.	Minimum Requirements for use of Preliminary Design Reduction Factor (RF) for Primary Geosynthetic Reinforcement.....	3-40
Table 3-14.	Additional MBW Cold Weather Requirements Recommended by Mn/DOT (2008).....	3-45
Table 4-1.	Typical MSE Wall Load Combinations and Load Factors (after Table 3.4.1-1, AASHTO, 2007).....	4-4
Table 4-2.	Typical MSE Wall Load Factors for Permanent Loads, γ_p (after Table 3.4.1-2, AASHTO, 2007).....	4-4
Table 4-3.	Basic LRFD Design Steps for MSE Walls.....	4-8
Table 4-4.	Equivalent Height of Soil, h_{eq} , for Traffic Loading on Abutments Perpendicular to Traffic (Table 3.11.6.4-1, AASHTO {2007}).....	4-17
Table 4-5.	External Stability Resistance Factors for MSE Walls (Table 11.5.6-1, AASHTO {2007}).....	4-19
Table 4-6.	Bearing Resistance Factors (Table 10.6.3.1.2a-1, AASHTO {2007}).....	4-29
Table 4-7.	Resistance Factors for Tensile and Pullout Resistance for MSE Walls (after Table 11.5.6-1, AASHTO (2007).....	4-48
Table 4-8.	Example MBW Faced MSE Wall Standard Design (Minnesota DOT, 2008) ..	4-82

Table 5-1.	Values of B for Various C_u Values for Soils with less than 50% Passing the No. 200 Sieve	5-27
Table 5-2.	Values of B and AOS for Soils with more than 50% Passing the No. 200 Sieve Based on Type of Geotextile	5-27
Table 5-3.	Geotextile Survivability Requirements (AASHTO M 288, 2006)	5-29
Table 5-4.	Recommended Minimum Properties for General Geomembrane Installation Survivability (after Koerner, 1998)	5-33

LIST OF FIGURES – Volume I

Figure 1-1.	Generic cross section of an MSE structure.....	1-4
Figure 1-2.	Generic cross sections of reinforced soil slope structures, reinforcements used to: (a) increase stability of a slope; and (b) provide improved compaction and surficial stability at edge of a slopes.....	1-5
Figure 2-1.	Representative MSE applications (a) retaining wall; (b) access ramp; (c) waterfront structure; and (d) bridge abutment.....	2-2
Figure 2-2.	MSE walls to support temporary bridge abutment roadway embankment.....	2-3
Figure 2-3.	MSE wall used to temporarily support a permanent roadway embankment for phased construction.....	2-3
Figure 2-4.	Application of reinforced soil slopes.....	2-5
Figure 2-5.	Cost evaluation of reinforced soil slopes.....	2-10
Figure 2-6.	Example MSE wall surface treatments.....	2-13
Figure 2-7.	Examples of commercially available MBW units (NCMA, 1997).....	2-14
Figure 2-8.	Erection of precast panels.....	2-21
Figure 2-9.	Fill spreading and reinforcement connection.....	2-22
Figure 2-10.	Compaction of reinforced wall fill.....	2-23
Figure 2-11.	Lift construction sequence for geosynthetic faced MSE walls.....	2-25
Figure 2-12.	Typical geosynthetic face construction detail.....	2-26
Figure 2-13.	Types of geosynthetic reinforced soil wall facing (after Wu, 1994).....	2-27
Figure 2-14.	Reinforced slope construction: (a) geogrid and fill placement; (b) soil filled erosion control mat placement; and (c) finished, vegetated 1:1 slope.....	2-29
Figure 2-15.	Empirical curve for estimating probable anticipated lateral displacement during construction for MSE walls (after FHWA 89-043 {Christopher et al., 1990}).....	2-41
Figure 2-16.	MSE wall embedment depth requirements, (a) level toe condition and (b) benched slope toe condition.....	2-44
Figure 2-17.	MSE wall construction on Mn/DOT Crosstown Project, 2008.....	2-48
Figure 2-18.	Veterans Memorial Overpass.....	2-49
Figure 2-19.	MSE true bridge abutment.....	2-49
Figure 2-20.	Typical cross section, VMO project.....	2-50
Figure 2-21.	SeaTac Airport runway extension MSE wall.....	2-51
Figure 2-22.	Guanella Pass wire-faced wall.....	2-52
Figure 2-23.	Guanella Pass architectural concrete faced wall.....	2-52
Figure 3-1.	Examples of reinforced fill zone extension beyond the reinforced zone.....	3-8
Figure 3-2.	Stress transfer mechanisms for soil reinforcement.....	3-11
Figure 3-3.	Coverage ratio.....	3-13
Figure 3-4.	Definition of grid dimensions for calculating pullout capacity.....	3-18
Figure 3-5.	Parameters for metal reinforcement strength calculations showing (a) steel strips and (b) metallic grids and bar mats.....	3-24
Figure 3-6.	Long-term geosynthetic reinforcement strength concepts.....	3-29
Figure 3-7.	Large, wet-cast concrete face unit with reinforcement placed between units. ..	3-48
Figure 3-8.	Large, wet-cast concrete face unit with embedded reinforcement connectors. .	3-49
Figure 3-9.	Geocell face unit with vegetation.....	3-49

Figure 4-1.	External stability load factors for simple walls.....	4-5
Figure 4-2.	External analysis: nominal earth pressures; horizontal backslope with traffic surcharge (after AASHTO, 2007)	4-12
Figure 4-3.	External analysis: earth pressure; sloping backfill case (after AASHTO, 2007).	4-13
Figure 4-4.	External analysis: earth pressure; broken backslope case (after AASHTO, 2007)	4-14
Figure 4-5.	Notation for Coulomb active earth pressures used with wall batters, θ , greater than 100° (after AASHTO, 2007).....	4-16
Figure 4-6.	Potential external failure mechanisms for a MSE wall.....	4-18
Figure 4-7.	Calculation of eccentricity and vertical stress for bearing check, for horizontal backslope with traffic surcharge condition	4-24
Figure 4-8.	Calculation of eccentricity and vertical stress for bearing check, for sloping backslope condition	4-25
Figure 4-9.	Location of potential failure surface for internal stability design of MSE Walls (a) inextensible reinforcements and (b) extensible reinforcements	4-34
Figure 4-10.	Variation of the coefficient of lateral stress ratio (K/K_a) with depth in a MSE wall (Elias and Christopher, 1997; AASHTO, 2002; after AASHTO, 2007) ..	4-37
Figure 4-11.	Calculation of vertical stress for sloping backfill conditions for internal stability.....	4-38
Figure 4-12.	Distribution of stress from concentrated vertical load for internal and external stability calculations.....	4-44
Figure 4-13.	Distribution of stresses from concentrated horizontal loads.....	4-45
Figure 4-14.	Reinforcement load contributory height	4-46
Figure 4-15.	Nominal vertical stress at the reinforcement level in the resistant zone, beneath a sloping backfill	4-50
Figure 4-16.	Bodkin connection detail (looking at cross section of segmental panel face	4-53
Figure 4-17.	Determination of hinge height for modular concrete block faced MSE walls (NMCA, 1997)	4-56
Figure 4-18.	Typical geometries where MSE wall compound stability is of concern: steep and tall backslope on top of the wall; tiered walls; slope at the toe of the wall; and water at toe of the slope	4-64
Figure 4-19.	Example of standard MSEW design. (Minnesota DOT, 2008)	4-83
Figure 5-1.	Example copings for MSE walls.....	5-2
Figure 5-2.	Example traffic barrier for MSE walls. (a) Barrier behind coping, (b) barrier on top of panels, (c) barrier on top of modular block units	5-5
Figure 5-3.	Leveling pads, (a) Common size, b) Step detail for precast panel facing units, (c) Step detail for modular block facing units	5-7
Figure 5-4.	Potential sources and flowpaths of water.....	5-10
Figure 5-5.	Example layout of filter at joints between segmental precast facing units.....	5-11
Figure 5-6.	Layout of drainage fabric and drainage fill at the face for modular block units. (Collin et al., 2002).....	5-12
Figure 5-7.	Example layout of geotextile filter near the face for welded wire facing units.	5-13
Figure 5-8.	Example drainage blanket detail behind the retained backfill	5-14
Figure 5-9.	Example drainage detail using a geocomposite sheet drain.....	5-15

Figure 5-10.	Example drainage detail using a blanket drain with chimney drain (Collin et al., 2002)	5-16
Figure 5-14.	Example detail for wall that may experience inundation.....	5-17
Figure 5-12.	Example MSE wall overflow sill at top of wall.....	5-19
Figure 5-13.	Example drainage swale near top of wall. ((b) Collin et al., 2002)	5-20
Figure 5-14.	(a) Example geomembrane barrier details, (b) Installation of geomembrane deicing salt runoff barrier, (c) Geomembrane installation around manhole penetration.....	5-22
Figure 5-15.	Example of undesirable water seepage through pavement due to deficient grades (Collin et al., 2002).....	5-23
Figure 5-16.	Example of surface flow erosion at the bottom of an MSE wall	5-24
Figure 5-17.	Examples of avoiding a vertical obstruction without severing soil reinforcements.....	5-37
Figure 5-18.	Vertical obstructions in reinforced soil mass with segmental precast facing units	5-39
Figure 5-19.	Example of a structural frame around vertical obstruction (a) with segmental precast facing - note that vertically adjacent layers of reinforcement to be separated by a minimum of 3-in. (75 mm) of wall fill, (b)-(c) with modular block face – note corner detail	5-40
Figure 5-20.	Example details of reinforcements around vertical obstructions in reinforced soil mass with modular block units.....	5-41
Figure 5-21.	Navigating horizontal obstruction in MSE walls with inextensible reinforcements.....	5-43
Figure 5-22.	Navigating horizontal obstruction in MSE walls with extensible reinforcement	5-43
Figure 5-23.	Example of backup panels for large horizontal obstructions.....	5-44
Figure 5-24.	Example pipe penetrations through segmental precast panel facing units	5-45
Figure 5-25.	Example pipe penetration through modular block facing units	5-46
Figure 5-26.	Example slip joints for segmental precast panel facings	5-48
Figure 5-27.	Example slip joint for modular block wall facings.....	5-49
Figure 5-28.	Example layout of geogrid reinforcement for walls with curves.....	5-50
Figure 5-29.	Example corner details.....	5-51
Figure 5-30.	Conceptual connection details for a 2-stage facing system	5-53
Figure 5-31.	Common joint details between segmental precast panel facing units and CIP structures	5-55
Figure 5-32.	Common joint between modular block facing units and CIP structures	5-55
Figure 5-33.	Example of MSE wall aesthetics	5-58
Figure 5-34.	Examples of cast-in-place abutment to MSE wall panel transitions.....	5-59
Figure 6-1.	Types of complex MSE structures.....	6-2
Figure 6-2.	Geometry definition, location of critical failure surface and variation of K_r and F^* parameters for analysis of a MSEW abutment on spread footing	6-4
Figure 6-3.	Details of a typical pile supported MSE abutment	6-7
Figure 6-4.	Geometry definition and typical supplemental lateral pressure distribution from deep foundation on MSE wall face	6-9
Figure 6-5.	Example of use of a geosynthetic wrapped face wall behind an integral abutment.....	6-12

Figure 6-6.	Example abutment seat detail	6-12
Figure 6-7.	Design rules for a 2-tier superimposed MSE wall system.....	6-14
Figure 6-8.	Dimensioning of MSE wall with uneven reinforcement lengths.....	6-17
Figure 6-9.	Back-to-back MSE walls.....	6-18
Figure 6-10.	Generic cross-section of a shored MSE (SMSE) wall system for steep terrains (Morrison et al., 2006)	6-19
Figure 6-11.	Minimum recommended geometry of a shored MSE wall system in steep terrains, (a) with extension of upper two rows of reinforcement, and (b) with the upper two rows connected to the shoring wall (Morrison et al., 2006)	6-21
Figure 6-12.	Location of potential failure surface for internal stability design of shored MSE walls (a) extensible reinforcements, (b) inextensible reinforcements (Morrison et al., 2006)	6-23
Figure 6-13.	Distribution of stress from concentrated vertical load for internal and external stability calculations (Morrison et al., 2006)	6-23
Figure 6-14.	Computation for T_{MAX} and evaluation of pullout resistance (after Morrison et al., 2006)	6-25
Figure 6-15.	Example global stability and compound failure surfaces (Morrison et al., 2006)	6-26
Figure 6-16.	Minimum recommended geometry of a stable feature MSE (SFMSE) wall system	6-28
Figure 7-1.	Definition of heights for seismic analyses.....	7-3
Figure 7-2.	Use of a slope stability approach to compute seismic earth pressure.....	7-6
Figure 7-3.	Procedure for determination of k_y (Anderson et al., 2008).....	7-7
Figure 7-4.	Boundary between WUS and CEUS (Anderson et al. 2008)	7-8
Figure 7-5.	Seismic internal stability of a MSE wall.....	7-10
Figure 7-6.	Comparison of static and dynamic impact force with 1-inch (25 mm) maximum displacement (Bligh et al., 2009).....	7-15

TABLE OF CONTENTS – Volume II

CHAPTER 8	REINFORCED (STEEPENED) SOIL SLOPES PROJECT EVALUATION	8-1
8.1	INTRODUCTION	8-1
8.2	REINFORCED SOIL SLOPE SYSTEMS	8-1
8.2.1	Types of Systems	8-1
8.2.2	Construction Materials	8-2
8.3	DESIGN APPROACH	8-2
8.3.1	Use Considerations	8-2
8.3.2	Design of Reinforcement for Compaction Aid	8-4
8.3.3	Design of Reinforcement for Steepening Slopes and Slope Repair	8-4
8.3.4	Computer-Assisted Design	8-6
8.3.5	Evaluation of External Stability	8-8
8.4	CONSTRUCTION SEQUENCE	8-11
8.5	TREATMENT OF OUTWARD FACE	8-15
8.5.1	Grass Type Vegetation	8-15
8.5.2	Soil Bioengineering (Woody Vegetation)	8-16
8.5.3	Armored	8-19
8.6	DESIGN DETAILS	8-20
8.6.1	Guardrail and Traffic Barriers	8-20
8.6.2	Drainage Considerations	8-20
8.6.3	Obstructions	8-21
8.7	CASE HISTORIES	8-21
8.7.1	The Dickey Lake Roadway Grade Improvement Project	8-21
8.7.2	Salmon-Lost Trail Roadway Widening Project	8-24
8.7.3	Cannon Creek Alternate Embankment Construction Project	8-26
8.7.4	Pennsylvania SR 54 Roadway Repair Project	8-27
8.7.5	Massachusetts Turnpike - Use of Soil Bioengineering	8-29
8.7.6	242-foot High 1H:1V Reinforced Soil Slope for Airport Runway Extension	8-32
8.8	STANDARD RSS DESIGNS	8-34
CHAPTER 9	DESIGN OF REINFORCED SOIL SLOPES	9-1
9.1	INTRODUCTION	9-1
9.2	REINFORCED SLOPE DESIGN GUIDELINES	9-3
9.2.1	Step 1 - Establish the geometric, loading, and performance requirements for design	9-3
9.2.2	Step 2 - Determine the engineering properties of the in-situ soils	9-3
9.2.3	Step 3 - Determine the properties of reinforced fill and, if different, the retained fill	9-5
9.2.4	Step 4 - Evaluate design parameters for the reinforcement	9-5
9.2.5	Step 5 - Check unreinforced stability	9-5
9.2.6	Step 6 - Design reinforcement to provide a stable slope	9-7
9.2.7	Step 7 - Check external stability	9-16
9.2.8	Step 8 - Seismic stability	9-18
9.2.9	Step 9 - Evaluate requirements for subsurface and surface water runoff control	9-19

9.3	COMPUTER ASSISTED DESIGN	9-23
9.4	PROJECT COST ESTIMATES	9-24
CHAPTER 10 CONTRACTING METHODS AND SPECIFICATIONS		
	FOR MSE WALLS AND SLOPES.....	10-1
10.1	POLICY DEVELOPMENT.....	10-2
10.2	SYSTEM OR COMPONENT APPROVALS.....	10-2
10.3	DESIGN AND PERFORMANCE CRITERIA	10-5
10.4	AGENCY OR SUPPLIER DESIGN	10-5
	10.4.1 Plan and Elevation Sheets.....	10-6
	10.4.2 Facing/Panel Details	10-7
	10.4.3 Drainage Facilities/Special Details.....	10-7
	10.4.4 Design Computations.....	10-7
	10.4.5 Geotechnical Report.....	10-7
	10.4.6 Construction Specifications	10-8
10.5	END RESULT DESIGN APPROACH	10-8
	10.5.1 Geometric Requirements	10-9
	10.5.2 Geotechnical Requirements	10-9
	10.5.3 Structural and Design Requirements	10-9
	10.5.4 Performance Requirements.....	10-10
10.6	STANDARD DESIGNS.....	10-10
	10.6.1 MSEW Standard Designs	10-10
	10.6.2 RSS Standard Designs	10-12
10.7	REVIEW AND APPROVALS.....	10-13
10.8	CONSTRUCTION SPECIFICATIONS AND SPECIAL PROVISIONS FOR MSEW AND RSS CONSTRUCTION.....	10-14
10.9	EXAMPLE SPECIFICATION FOR MSE WALLS	10-15
10.10	CONSTRUCTION SPECIFICATIONS FOR REINFORCED SLOPE SYSTEMS	10-41
	10.10.1 Specification Guidelines For RSS Construction (Agency Design)	10-42
	10.10.2 Specification for Erosion Control Mat or Blanket.....	10-46
	10.10.3 Specification for Geosynthetic Drainage Composite.....	10-48
	10.10.4 Specification Guidelines for Geosynthetic Reinforced Soil Slope Systems	10-52
CHAPTER 11 FIELD INSPECTION AND PERFORMANCE MONITORING.....		
11.1	PRECONSTRUCTION REVIEWS.....	11-1
	11.1.1 Plans and Specifications	11-3
	11.1.2 Review of Site Conditions and Foundation Requirements.....	11-3
11.2	PREFABRICATED MATERIALS INSPECTION.....	11-11
	11.2.1 Precast Concrete Elements.....	11-11
	11.2.2 Reinforcing Elements.....	11-13
	11.2.3 Facing Joint Materials.....	11-15
	11.2.4 Reinforced Backfill.....	11-15
11.3	CONSTRUCTION CONTROL.....	11-16
	11.3.1 Leveling Pad	11-16
	11.3.2 Erection of Facing Elements.....	11-16

11.3.3	Reinforced Fill Placement, Compaction	11-22
11.3.4	Placement of Reinforcing Elements.....	11-25
11.3.5	Placement of Subsequent Facing Courses (Segmental Facings)	11-26
11.4	PERFORMANCE MONITORING PROGRAMS	11-35
11.4.1	Purpose of Monitoring Program	11-35
11.4.2	Limited Monitoring Program.....	11-36
11.4.3	Comprehensive Monitoring Program	11-37
11.4.4	Program Implementation	11-37
11.4.5	Data Interpretation	11-40
	REFERENCES	R-1

APPENDICES

APPENDIX A	LRFD LOAD COMBINATIONS AND LOAD FACTORS, AND LOAD FACTOR FOR PERMANENT LOADS	A-1
APPENDIX B	DETERMINATION OF PULLOUT RESISTANCE FACTORS	B-1
B.1	EMPIRICAL PROCEDURES TO DETERMINE F^* AND α	B-1
B.2	EXPERIMENTAL PROCEDURES TO DETERMINE F^* AND α	B-2
B.3	CONNECTION RESISTANCE AND STRENGTH OF PARTIAL AND FULL FRICTION SEGMENTAL BLOCK/REINFORCEMENT FACING CONNECTIONS	B-5
B.4	CONNECTION RESISTANCE DEFINED WITH SHORT-TERM TESTING	B-12
B.5	REFERENCES	B-15
APPENDIX C	TYPICAL DIMENSIONS OF STEEL REINFORCEMENTS	C-1
APPENDIX D	DETERMINATION OF CREEP STRENGTH REDUCTION FACTOR ...	D-1
D.1	BACKGROUND	D-1
D.2	STEP-BY-STEP PROCEDURES FOR EXTRAPOLATING STRESS RUPTURE DATA -- CONVENTIONAL METHOD.....	D-5
D.3	STEP-BY-STEP PROCEDURES FOR EXTRAPOLATING STRESS RUPTURE DATA -- STEPPED ISOTHERMAL METHOD (SIM).....	D-10
D.4	DETERMINATION OF RF_{CR}	D-13
D.5	USE OF CREEP DATA FROM "SIMILAR" PRODUCTS AND EVALUATION OF PRODUCT LINES	D-14
D.6	CREEP EXTRAPOLATION EXAMPLES USING STRESS RUPTURE DATA	E-16
D.6.1	Stress Rupture Extrapolation Example	E-16
D.7	REFERENCES	E-20

APPENDIX E EXAMPLE CALCULATIONS

E.1	MBW Unit Faced MSE Wall with Broken Back Sloping Fill and Live Load Surcharge, Reinforced with Geogrid	E.1-1
E.2	Bearing Check for Sloping Toe Conditions, with and without Water	E.2-1
E.3	Segmental Precast Panel MSE Wall with Sloping Backfill Surcharge, Reinforced with Steel Strips	E.3-1
E.4	Segmental Precast Panel MSE Wall with Level Backfill and Live Load Surcharge, Reinforced with Steel Bar Mats.....	E.4-1
E.5	True Bridge Abutment with Segmental Precast Panel MSE Wall, Reinforced with Steel Strips	E.5-1
E.6	Traffic Barrier Impact Loading on Top of an MSE Wall	E.6-1
E.7	Seismic Loading . . . , Psuedo-Static Analysis.....	E.7-1
E.8	Reinforced Soil Slope Design -- Road Widening.....	E.8-1
E.9	Reinforced Soil Slope Design -- High Slope for New Road Construction.	E.9-1
E.10	Reinforced Soil Slope Design -- Facing Stability Calculation	E.10-1

APPENDIX F OTHER DESIGN PROCEDURES AND ANALYSIS MODELS

F.1	ASD Procedure and the Simplified Method	F-2
F.2	Coherent Gravity Method	F-3
F.3	National Concrete Masonry Association Procedure	F-5
F.4	GRS	F-5
F.5	FHWA Structural Stiffness Method.....	F-7
F.6	K-Stiffness Method.....	F-8
F.7	Deep Patch	F-11

LIST OF TABLES – Volume II

Table 8-1.	RSS Slope Facing Options (after Collin, 1996).....	8-14
Table 9-1.	Estimated Project Costs.	9-25
Table 11-1.	Outline of MSE/RSS Field Inspection Checklist.....	11-2
Table 11-2.	Checklist for Drawing Review.....	11-5
Table 11-3.	Checklist for Specification Compliance.	11-7
Table 11-4.	Out-of-Tolerance Conditions and Possible Causes.....	11-30
Table 11-5.	Checklist for Construction.	11-32
Table 11-6.	Possible Instruments for Monitoring Reinforced Soil Structures.	11-38

LIST OF FIGURES – Volume II

Figure 8-1.	Failure modes for reinforced soil slopes including internal failure within the reinforced soil zone, external failure entirely outside the reinforced soil zone, and compound failure starting behind and passing through the reinforced soil zone	8-3
Figure 8-2.	Modified limit equilibrium analysis for reinforced slope design.....	8-5
Figure 8-3.	External failure modes for reinforced soil slopes.	8-9
Figure 8-4.	Construction of reinforced soil slopes.	8-12
Figure 8-5.	Welded wire mesh detail for temporary (during construction) or permanent face support.	8-15
Figure 8-6.	Components of a vegetated reinforced slope (VRSS) system	8-17
Figure 8-7.	Dickey Lake site.	8-23
Figure 8-8.	Salmon Lost Trail site.	8-25
Figure 8-9.	Cannon Creek project.	8-26
Figure 8-10.	Pennsylvania SR54.	8-28
Figure 8-11.	Massachusetts Turnpike during construction, immediately after construction and after the second growing season.	8-31
Figure 8-12.	Reinforced soil slope for runway extension at Yeager Airport, Charleston, West Virginia.....	8-33
Figure 8-13.	Example of standard RSS design.....	8-36
Figure 9-1.	Flow chart of steps for reinforced soil slope design.	9-2
Figure 9-2.	Requirements for design of reinforced soil slopes.....	9-4
Figure 9-3.	Critical zone defined by rotational and sliding surface that meet the required safety factor.....	9-6
Figure 9-4.	Rotational shear approach to determine required strength of reinforcement.....	9-8
Figure 9-5.	Chart solution for determining the reinforcement strength requirements.....	9-10
Figure 9-6.	Reinforcement spacing considerations for high slopes.....	9-11
Figure 9-7.	Developing reinforcement lengths.....	9-14
Figure 9-8.	Failure through the foundation.....	9-17
Figure 9-9.	Seismic stability analysis.....	9-19
Figure 9-10.	Subsurface drainage considerations.....	9-20
Figure 11-1.	Casting yard for precast facing elements.....	11-12
Figure 11-2.	Inspect reinforcing elements: top photo shows a variety of reinforcements including metallic strips, welded wire mesh, and geosynthetics and bottom photo shows reinforcement length painted on geogrid reinforcement.....	11-14
Figure 11-3.	Leveling pads: a) leveling the concrete, b) completed pad, and c) placing the facing elements on the leveling pad.....	11-17
Figure 11-4.	Checking facing element batter and alignment.....	11-18
Figure 11-5.	Full height facing panels require special alignment care.....	11-19
Figure 11-6.	Setting first row of precast facing elements.....	11-21
Figure 11-7.	Placement of reinforced fill.	11-23
Figure 11-8.	Compaction equipment showing: a) large equipment permitted away from face; and b) lightweight equipment within 3 ft (1 m) of the face.	11-24

Figure 11-9. Facing connection examples 11-27
Figure 11-10. Geotextile joint cover and neoprene pads 11-29

CHAPTER 1

INTRODUCTION

1.1 OBJECTIVES

New methods and technologies of retention and steepened-slope construction continue to be developed, often by specialty contractors and suppliers, to solve problems in locations of restricted Right-of-Way (ROW), at marginal sites with difficult subsurface conditions and other environmental constraints, and to expedite construction. Professionals charged with the responsibility for planning, designing, and implementing improvements and additions in such locations should understand the application, limitations and costs associated with a host of measures and technologies available.

This manual was prepared to assist design engineers, specification writers, estimators, construction inspectors and maintenance personnel with the selection, design, construction and maintenance of Mechanically Stabilized Earth Walls (MSEW) and Reinforced Soil Slopes (RSS).

The design, construction and monitoring techniques for these structures have evolved over the last three decades as a result of efforts by researchers, material suppliers and government agencies to improve some single aspect of the technology or the materials used. This manual is a comprehensive document that integrates all design, construction, materials, contracting, and monitoring aspects required for successful project implementation.

This manual has been developed in support of FHWA educational programs on the design, construction, and maintenance of MSE wall and RSS structures construction. Its principal function is to serve as a reference source to the materials presented. The manual serves as FHWA's primary technical guideline on the use of these technologies on transportation facilities.

1.1.1 Scope

The manual addresses in a comprehensive manner the following areas:

- Overview of MSE development and the cost, advantages, and disadvantages of using MSE structures.
- Available MSE systems and applications to transportation facilities.
- Basic soil-reinforcement interaction.
- Design of routine and complex MSE walls.

- Design of MSE walls for extreme events.
- Design detailing of MSE walls.
- Design of steepened RSS.
- Specifications and contracting approaches for both MSE walls and RSS construction.
- Construction monitoring and inspection.
- Design examples.
- A separate companion manual addresses long-term corrosion of metallic reinforcements and long-term degradation of polymeric reinforcements. Sections of the Corrosion/Degradation manual address the background of full-scale, long-term evaluation programs and the procedures required to develop, implement, and evaluate them. These procedures have been developed to provide practical information on this topic for MSE users for non-corrosion or polymer specialists, who are interested in developing long-term monitoring programs for these types of structures.

As an integral part of this Manual, several example calculations are appended that demonstrate individual design aspects.

1.1.2 Source Documents

This Mechanically Stabilized Earth Walls (MSE) and Reinforced Soil Slopes (RSS), Design and Construction Guidelines Manual is an update of the current FHWA NHI-00-043 (Elias et al., 2001), has evolved from the following AASHTO and FHWA references:

- AASHTO LRFD Bridge Design Specifications, 4th Edition, 2007, with 2008 and 2009 Interim Revisions
- *Earth Retaining Structures*, FHWA-NHI-07-071 (Tanyu et al., 2008)
- AASHTO LRFD Bridge Construction Specifications, 2nd Edition, 2004, with 2006, 2007, 2008, and 2009 Interim Revisions
- *Geosynthetic Design and Construction Guidelines*, FHWA NHI-07-092 (Holtz et al., 2008)
- *Guidelines for Design, Specification, and Contracting of Geosynthetic Mechanically Stabilized Earth Slopes on Firm Foundations*, FHWA-SA-93-025 (Berg, 1993)
- *Reinforced Soil Structures - Volume I, Design and Construction Guidelines - Volume II, Summary of Research and Systems Information*, FHWA RD 89-043 (Christopher et al. 1990)
- *Mechanically Stabilized Earth Walls and Reinforced Soil Slopes, Design and Construction Guidelines*, FHWA, (Elias and Christopher, 1997)

Additional guidance, where not available from other sources, was specifically developed for this manual.

1.1.3 Terminology

Certain interchangeable terms will be used throughout this manual. For clarity, they are defined as follows:

Inclusion is a generic term that encompasses all man-made elements incorporated in the soil to improve its behavior. Examples of inclusions are steel strips, geotextile sheets, steel or polymeric grids, steel nails, and steel tendons between anchorage elements. The term *reinforcement* is used only for those inclusions where soil-inclusion stress transfer occurs continuously along the inclusion.

Mechanically Stabilized Earth Wall (MSE wall or MSEW) is a generic term that includes reinforced soil (a term used when multiple layers of inclusions act as reinforcement in soils placed as fill). Reinforced Earth[®] is a trademark for a specific reinforced soil system.

Reinforced Soil Slopes (RSS) are a form of reinforced soil that incorporate planar reinforcing elements in constructed earth-sloped structures with face inclinations of less than 70 degrees.

Geosynthetics is a generic term that encompasses flexible polymeric materials used in geotechnical engineering such as geotextiles, geomembranes, geonets, and geogrids.

Facing is a component of the reinforced soil system used to prevent the soil from raveling out between the rows of reinforcement. Common facings include precast concrete panels, dry cast modular blocks, gabions, welded wire mesh, shotcrete, timber lagging and panels, polymeric cellular confinement systems, and wrapped sheets of geosynthetics. The facing also plays a minor structural role in the stability of the structure. For RSS structures it usually consists of welded wire mesh, geosynthetic wrap-around, and/or some type of erosion control material.

Retained backfill is the fill material located behind the mechanically stabilized soil zone.

Reinforced fill is the fill material in which the reinforcements are placed.

Generic cross sections of MSE structures are shown in Figures 1-1 and 1-2.

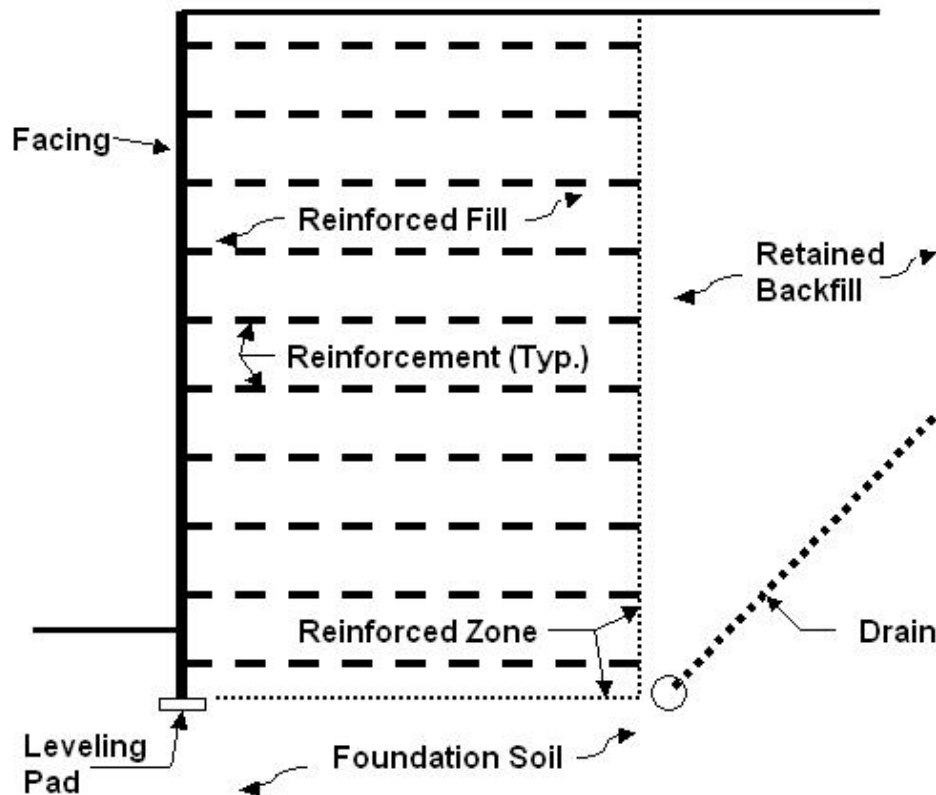
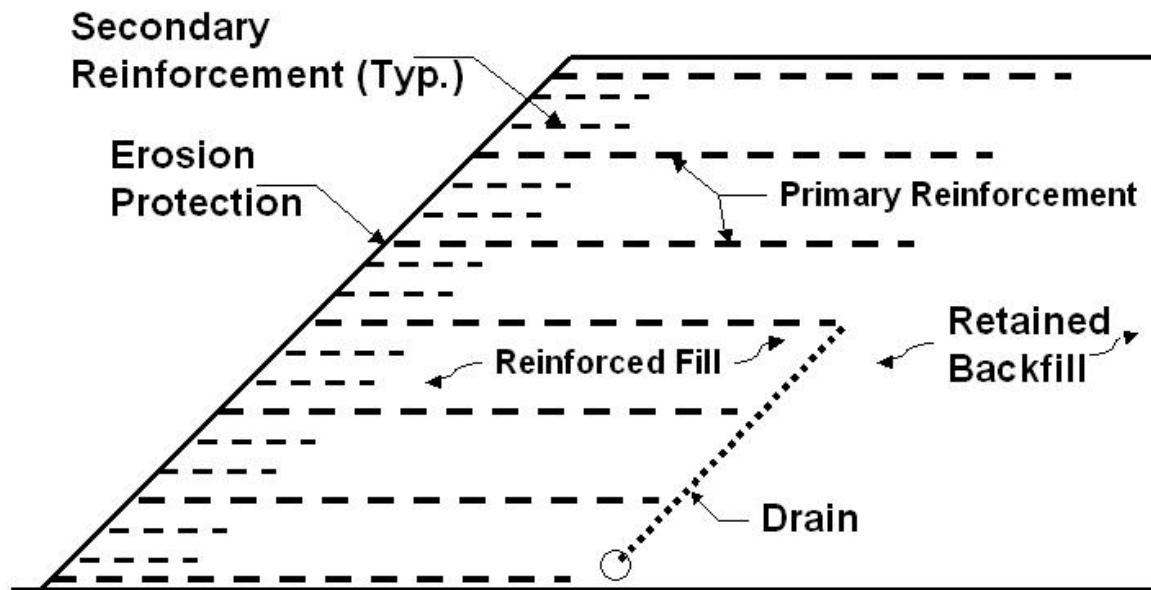

Figure 1-1. Generic cross section of an MSE structure.

1.2 HISTORICAL DEVELOPMENT

Retaining structures are essential elements of every highway design. Retaining structures are used not only for bridge abutments and wing walls but also for slope stabilization and to minimize right-of-way for embankments. For many years, retaining structures were almost exclusively made of reinforced concrete and were designed as gravity or cantilever walls which are essentially rigid structures and cannot accommodate significant differential settlements unless founded on deep foundations. With increasing height of soil to be retained and poor subsoil conditions, the cost of reinforced concrete retaining walls increases rapidly.

Mechanically Stabilized Earth Walls (MSEWs) and Reinforced Soil Slopes (RSSs) are cost-effective soil-retaining structures that can tolerate much larger settlements than reinforced concrete walls. By placing tensile reinforcing elements (inclusions) in the soil, the strength of the soil can be improved significantly. Use of a facing system to prevent soil raveling between the reinforcing elements allows very steep slopes and vertical walls to be constructed safely.



(a)

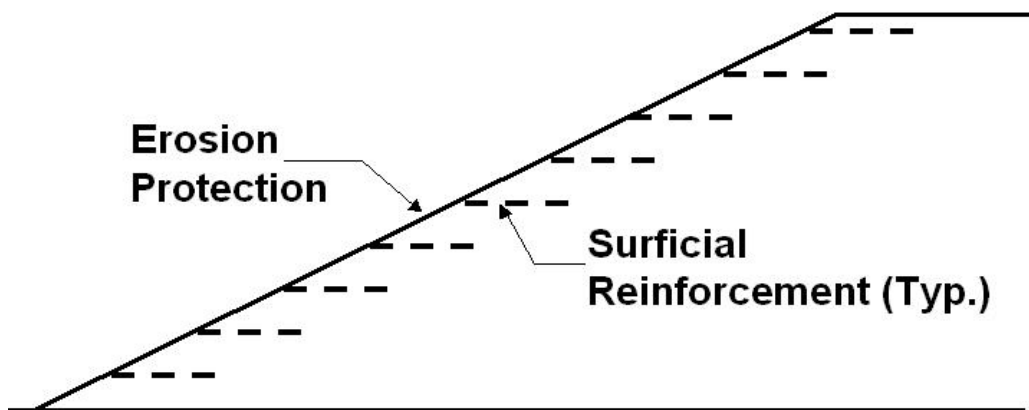

(b)

Figure 1-2. Generic cross sections of reinforced slope structures, reinforcements used to: (a) increase stability of a slope; and (b) provide improved compaction and surficial stability at edge of slopes (after Berg et al., 1990).

Inclusions have been used since prehistoric times to improve soil. The use of straw to improve the quality of adobe bricks dates back to earliest human history. Many primitive people used sticks and branches to reinforce mud dwellings. During the 17th and 18th centuries, French settlers along the Bay of Fundy in Canada used sticks to reinforce mud dikes. Some other early examples of man-made soil reinforcement include dikes of earth and tree branches, which have been used in China for at least 1,000 years (e.g., western portion of the Great Wall) and along the Mississippi River in the 1880s. Other examples include wooden pegs used for erosion and landslide control in England, and bamboo or wire mesh, used universally for revetment erosion control. Soil reinforcing can also be achieved by using live plant roots.

The modern methods of soil reinforcement for retaining wall construction were pioneered by the French architect and engineer Henri Vidal in the early 1960s. His research led to the invention and development of Reinforced Earth[®], a system in which steel strip reinforcement is used. The first wall to use this technology in the United States was built in 1972 on California State Highway 39, northeast of Los Angeles. Today, MSE walls are the wall of choice in most fill situations, and MSE walls are used extensively in the U.S. and worldwide. The highest permanent wall constructed in the United States is on the order of 150 ft (46 m) with an exposed height of approximately 135 ft (41 m).

Since the introduction of Reinforced Earth[®], several other proprietary and nonproprietary systems have been developed and used. Table 1-1 provides a partial summary of some of the current systems by proprietary name, reinforcement type, and facing system.

There are many available systems, as well as new systems that continue to be introduced into the market. Components, engineering details, system quality controls, etc. vary with each system. States, therefore, need a process to sort and evaluate MSE wall systems for potential pre-approval for use on their projects. The Highway Innovative Technology Evaluation Center (HITEC) provides review and evaluation of MSE walls. HITEC was established in 1994 within the American Society of Civil Engineers (ASCE) organization. HITEC's purpose is to accelerate the introduction of technological advances in products, systems, services, materials, and equipment to the highway and bridge markets. The evaluation of new and more cost-effective retaining wall systems is performed through HITEC's nationally-focused, earth retaining system (ERS) group evaluation program. The published reports provide reviews of design, construction, performance, and quality assurance information provided by the wall system suppliers with respect to conformance with the state-of-practice criteria as outlined in the HITEC Protocol. Wall system suppliers are encouraged to conduct an independent review of newly developed components and/or systems related to materials, design, construction, performance, and quality assurance. Some

public agencies, especially state DOTs, require HITEC evaluations or independent evaluations of wall components or wall systems, and obtaining such reviews has proven beneficial to wall system suppliers in securing acceptance of their system.

Currently, most process patents covering soil-reinforced system construction or components have expired, leading to a proliferation of available systems or components that can be separately purchased and assembled by the erecting contractor. The combination of components needs to be evaluated to assure compatibility with respect to longevity, constructability, and connection strength. The remaining patents in force generally cover only the method of connection between the reinforcement and the facing.

In the United States, a segmental precast facing unit 20 to 25 ft² (2 to 2.25 m²) generally square in shape is the facing unit of choice. More recently, larger precast units of up to 50 ft² (4.6 m²) have been used and are becoming more commonplace. Additionally, smaller dry-cast concrete masonry units are being used, generally in conjunction with geosynthetic reinforcements.

Table 1-1. Summary of Reinforcement and Face Details for MSE Wall Systems.

<u>System Name</u>	<u>Reinforcement Detail</u>	<u>Typical Face Detail</u>¹
Stabilized Earth Wall T&B Structural Systems LLC 6800 Manhattan Blvd, Suite 304 Ft. Worth Texas 76120	Galvanized welded steel wire mesh with W7 to W20 bars. Mesh width and spacing can vary. Epoxy-coated meshes also available.	Precast concrete panels 5 ft x 5 ft x 6 in. thick or 5 ft x 10 ft x 6 in. thick. Different size panels used at top and bottom to match project requirements.
Reinforced Earth® The Reinforced Earth Company 8614 Westwood Center Drive Suite 1100 Vienna, VA 22182-2233	Ribbed galvanized steel strips, 0.157 in. thick, 2 in. wide. Or galvanized steel ladder strips, W10 wire, two longitudinal wires and cross bars spaced at 6 in.	Cruciform and square shaped precast concrete nominally 5 ft x 5 ft x 5.0 to 5.5 in. thick. Also rectangular shaped precast concrete nominally 5 ft x 10 ft x 5.5 in. thick. Variable height panels used at top and bottom of wall.
Retained Earth® The Reinforced Earth Company 8614 Westwood Center Drive Suite 1100 Vienna, VA 22182-2233	Rectangular grid of W11, W15 or W20 galvanized steel wire, 24 x 6 in. grid. 2, 4, 5 or 6 longitudinal bars. Stainless steel mesh used in marine and corrosive environments.	Hexagonal and square precast concrete 5 ft x 5 ft x 5.5 in. thick. Also rectangular shaped precast concrete 5 ft x 10 ft x 5.5 in. thick. Variable height panels used at top and bottom of wall.
Mechanically Stabilized Embankment California Dept. of Transportation 1801 30 th Street P.O. Box 168041 Sacramento, CA 95816	Rectangular grid of W11, W15, and W20 galvanized welded wire mats, 6 longitudinal wires with variable transverse spacing.	Precast concrete; 5 ft square, 6 in. thick.
ARES Tensar International Corporation 5883 Glenridge Drive, Suite 200 Atlanta, GA 30328	HDPE Geogrid	Precast concrete panel; rectangular 9 ft wide, 5 ft high, 5.5 in. thick.
Wire Faced Wall T&B Structural Systems LLC 6800 Manhattan Blvd, Ste 304 Ft. Worth Texas 76120	4 ft wide welded steel wire mesh. Mesh is 8 in. x 12, 18 or 24 in., of W4.5 to W20 bars. Size and configuration are variable.	Welded steel wire mesh facing. Several veneer facing options available.

<u>System Name</u>	<u>Reinforcement Detail</u>	<u>Typical Face Detail¹</u>
Welded Wire Wall Hilfiker Retaining Walls 1902 Hilfiker Lane Eureka, CA 95503	Welded steel wire mesh, Galvanized or Non-Galvanized. Mesh reinforcements vary in spacing and gauges to meet project design specifications.	Welded steel wire mesh, 2' tall x 8' wide typical. Backing mat, Hardware Cloth or Filter Fabric depending on project. (With geotextile or shotcrete, if desired).
Reinforced Soil Embankment Hilfiker Retaining Walls 1902 Hilfiker Lane Eureka, CA 95503	Welded steel wire mesh, Galvanized or Non-Galvanized. Mesh reinforcements vary in spacing and gauges to meet project design specifications.	Precast concrete unit 12.5 ft long, 24 in. high.
ArtWeld Gabions Hilfiker Retaining Walls 1902 Hilfiker Lane Eureka, CA 95503	Welded steel wire mesh, Galvanized or Non-Galvanized. Mesh reinforcements vary in spacing and gauges to meet project design specifications.	ArtWeld Gabion baskets of various sizes and heights designed per project requirements.
Gabion Faced M.S.E. Hilfiker Retaining Walls 1902 Hilfiker Lane Eureka, CA 95503	Welded steel wire mesh, Galvanized or Non-Galvanized. Mesh reinforcements vary in spacing and gauges to meet project design specifications.	ArtWeld Gabions of various sizes and heights connected to reinforcing mesh by spiral binders.
Eureka Reinforced Soil Hilfiker Retaining Walls 1902 Hilfiker Lane Eureka, CA 95503	Welded steel wire mesh, Galvanized or Non-Galvanized. Mesh reinforcements vary in spacing and gauges to meet project design specifications.	Precast or cast-in-place concrete facing panels, shotcrete, sculpted shotcrete, or stacked stone.
Steepened Slope Hilfiker Retaining Walls 1902 Hilfiker Lane Eureka, CA 95503	Welded steel wire mesh, Galvanized or Non-Galvanized. Mesh reinforcements vary in spacing and gauges to meet project design specifications.	Welded steel wire mesh, 1 to 1 slope typical. Hardware Cloth or Filter Fabric depending on project. (With geotextile or shotcrete, if desired).
INTER-LOK Atlantic Concrete Industries P.O. Box 129 Tullytown, PA 19007	0.63 or 0.75 in. reinforcing steel bars fitted with 5 x 10 x 0.4 in. anchor plates and connected to a keyplate, and galvanized after fabrication.	Precast concrete panel; cross-shaped 6 ft wide and 3 ft high, 8 and 10 in. thick.
ISOGRID Neel Co. 6520 Deepford Street Springfield, VA 22150	Rectangular grid of W11 x W11 4 bars per grid.	Diamond shaped precast concrete units, 5 ft x 8 ft, 5.5 in. thick.
T-Block Wall System T&B Structural Systems LLC 6800 Manhattan Blvd Ste 304 Ft. Worth Texas 76120	Rectangular 4 ft wide welded steel wire mesh of W7 to W20 steel bars.	Dry cast concrete block 8 in high x 16 in long x 12 in deep.
MESA Tensar International Corporation 5883 Glenridge Drive, Suite 200 Atlanta, GA 30328	HDPE Geogrid	MESA HP (high performance), DOT ³ OR Standard units (8 in. high by 18 in. long face, 10.8 in. nominal depth). (dry cast concrete)
Pyramid TM The Reinforced Earth Company 8614 Westwood Center Drive Suite 1100 Vienna, VA 22182-2233	Galvanized welded wire ladders. Size varies with design requirements.	Dry cast concrete units, 8 in. high, 16 in. nominal length at face, 10 in. nominal depth.
Omega The Reinforced Earth Company 8614 Westwood Center Drive Suite 1100 Vienna, VA 22182-2233	Geostraps composed of high tenacity polyester with polyethylene sheathing. Reinforcement used in marine and corrosive environments only.	Cruciform and square shaped precast concrete 5 ft x 5 ft x 5.5 in. thick. Also rectangular shaped precast concrete 5 ft x 10 ft x 5.5 in. thick. Variable height panels used at top and bottom of wall.
Geotrel TM The Reinforced Earth Company 8614 Westwood Center Dr, Ste 1100 Vienna, VA 22182	Geostraps composed of high tenacity polyester with polyethylene sheathing. Only used in temporary walls.	Welded steel wire mesh with geotextile backing.

<u>System Name</u>	<u>Reinforcement Detail</u>	<u>Typical Face Detail¹</u>
Terratrel™ The Reinforced Earth Company 8614 Westwood Center Drive Suite 1100 Vienna, VA 22182-2233	Ribbed galvanized steel strips, 0.157 in. thick, 2 in. wide. Or, galvanized steel ladder strips or mesh. Size varies with design requirements.	Welded steel wire mesh with geotextile backing or stone fill at wall face.
Maccaferri Terramesh System Maccaferri Gabions, Inc. 43A Governor Lane Blvd. Williamsport, MD 21795	Continuous sheets of galvanized double twisted woven wire mesh with PVC coating.	Rock filled gabion baskets laced to reinforcement.
Strengthened Earth Gifford-Hill & Co. 2515 McKinney Ave. Dallas, Texas 75201	Rectangular grid, W7, W9.5 and W14, transverse bars at 9 and 18 in.	Precast concrete units, rectangular or wing shaped, 6 ft x 7 ft x 5.5 in.
MSE Plus SSL 4740 Scotts Valley Drive Scotts Valley, CA 95066	Rectangular grid with W8 to W24 longitudinal bars and W8 to W20 transverse. Mesh may have 2 – 6 longitudinal bars spaced at 6 or 8 in.	Rectangular precast concrete panels 5 ft high, 5, 6, 10, and 12 ft wide, with a thickness of 6 or 7 in.
KeySystem – Inextensible Keystone Retaining Wall Systems 4444 W. 78 th Street Minneapolis, MN 55435	Galvanized welded wire ladder mat of W7.5 to W17 bars with crossbars at 6 – 24 in.	KeySystem concrete facing unit is 8 in high x 18 in. wide x 12 in. deep (dry cast concrete).
KeySystem – Extensible Keystone Retaining Wall Systems 4444 W. 78 th Street Minneapolis, MN 55435	Miragrid high-tenacity polyester geogrid soil reinforcement by TenCate Mirafi, polymer coated.	Keystone Compac concrete facing units are 8 in. high x 18 in. wide x 12 in. deep (dry cast concrete).
Tricon System Tricon Precast Ltd. 15055 Henry Road Houston, TX 77060	Galvanized welded-wire.	Rectangular precast concrete panels with a face area of 45 sq. ft.
Versa-Lok Retaining Wall Systems 6348 Highway 36 Blvd. Oakdale, MN 55128	PVC coated PET or HDPE geogrids.	Versa-Lok concrete unit 6 in. high x 16 in. long x 12 in. deep (dry cast concrete)
Anchor Wall Systems 5959 Baker Road Minnetonka, MN 55345	PVC coated PET geogrid.	Anchor Landmark concrete unit 15 in. high x 8 in. long x 12 (small unit) or 12.5 (large unit) in. deep (dry cast concrete).
EarthTrac™ HA EarthTec Inc. 413 Browning Ct. Purcellville, VA 20132	Ribbed galvanized steel strips, 0.188 in. thick by 2.36 in. wide.	Rectangular 5 ft x 10 ft precast concrete panels.
EarthTrac™ Wire EarthTec Inc. 413 Browning Ct. Purcellville, VA 20132	Ribbed steel strips, 0.188 in. thick by 2.36 in. wide; galvanized for permanent walls.	Welded wire basket 2.5 ft high by 10 ft wide.
EarthTrac™ Synthetic EarthTec Inc. 413 Browning Ct. Purcellville, VA 20132	PVC coated high tenacity polyester geostraps.	Precast concrete panels, rectangular or T-shaped.

¹Additional facing types are possible with most systems.

The use of geotextiles in MSE walls and RSS started after the beneficial effect of reinforcement with geotextiles was noticed in highway embankments constructed over weak subgrades. The first geotextile-reinforced wall was constructed in France in 1971, and the first structure of this type in the United States was constructed in 1974. Geogrids for soil

reinforcement were developed around 1980. The first use of geogrid in earth reinforcement was in 1981. Extensive use of geogrid products in the United States started in about 1983, and they now comprise a growing portion of the market. Since the early 1980s, the use of geosynthetics in reinforced soil structures has increased significantly.

The first reported use of reinforced steepened slopes is believed to be the west embankment for the Great Wall of China. The introduction and economy of geosynthetic reinforcements has made the use of steepened slopes economically attractive. A survey of usage in the mid 1980s identified several hundred completed projects. At least an order of magnitude more RSS structures have been constructed since that study. The highest constructed RSS structure in the U.S. to date is 242 ft (74 m) (see Chapter 8).

A representative list of geosynthetic reinforcement manufacturers and suppliers is shown in Table 1-2.

Current Usage: It is believed that MSEWs have been constructed in every state in the United States. Major users include transportation agencies in Georgia, Florida, Texas, Pennsylvania, New York, and California, which rank among the largest road building states.

It is estimated that more than 9,000,000 ft² (850,000 m²) of MSE retaining walls with precast facing are constructed on average every year in the United States, which may represent more than half of all retaining wall usage for transportation applications.

The majority of the MSEWs for permanent applications either constructed to date or presently planned use a segmental precast concrete facing and galvanized steel reinforcements. The use of geotextile faced MSEWs in permanent construction has been limited to date. They are quite useful for temporary construction, where more extensive use has been made.

Recently, modular block dry cast facing units have gained acceptance due to their lower cost and nationwide availability. These small concrete units are generally mated with grid reinforcement, and the wall system is referred to as modular block wall (MBW). It is estimated that more than 3,000,000 ft² (280,000 m²) of MBW walls have been constructed yearly in the United States when considering all types of transportation related applications. The current yearly usage for transportation-related applications is estimated at about 100 projects per year.

The use of RSS structures has expanded dramatically in the last decade, and it is estimated that several hundred RSS structures have been constructed in the United States. Currently,

100 to 150 RSS projects are being constructed yearly in connection with transportation related projects in the United States, with an estimated projected vertical face area of 2,000,000 ft²/year (190,000 m²/yr).

Table 1-2 – Representative List of Geogrid and Geotextile Reinforcement Suppliers.

<p>ACE Geosynthetics Enterprise Co., Ltd. No. 8 Kung 10 Rd. Yu-Shih Ind. Park, Tachia Taichung 43768 Taiwan www.geoace.com</p>	<p>Belton Industries Inc. 5600 Oakbrook Pkwy Ste 150 Norcross, GA 30093-1843 www.beltonindustries.com</p>
<p>Carthage Mills 4243 Hunt Rd Cincinnati, OH 45242-6645 www.carthagemills.com</p>	<p>Checkmate Geosynthetics Inc. Unit# 412 44500 South Sumas Rd. Chilliwack, BC V2R 5M3 Canada www.checkmategeogrid.com</p>
<p>Colbond Inc. PO Box 1057 1301 Sand Hill Rd Enka, NC 28728-1057 www.colbond.com</p>	<p>Fiberweb PLC 70 Old Hickory Blvd. Old Hickory, TN 37138 www.fiberweb.com</p>
<p>Dalco Nonwovens PO Box 1479 2050 Evergreen Dr Ne Conover, NC 28613-1479 www.dalcononwovens.com</p>	<p>Geo-Synthetics Inc. 2401 Pewaukee Rd Waukesha, WI 53188 www.geo-synthetics.com</p>
<p>GSE Lining Technology Inc. 19103 Gundle Rd Houston, TX 77073-3515 www.gseworld.com</p>	<p>Highland Industries Inc 629 Green Valley Rd., Suite 210 Greensboro, NC 27408 www.highlandindustries.com</p>
<p>Huesker Inc. PO Box 411529 Charlotte, NC 28241-1529 www.hueskerinc.com</p>	<p>Layfield Plastics Inc. 11603 180th St SW Edmonton, AB T5S 2H6 Canada www.layfieldgroup.com</p>
<p>Luckenhaus Technical Textiles Inc. 3130 Bee Tree Ln Signal Mountain, TN 37377-1441</p>	<p>Maccaferri Inc. 10303 Governor Lane Blvd Williamsport, MD 21795-3115 www.maccaferri-usa.com</p>
<p>NAUE America Inc. 3525 Piedmont Rd NE 7 Piedmont Center Ste 300 Atlanta, GA 30305-1578 www.naue.com</p>	<p>Propex Geosynthetics 6025 Lee Highway, Ste. 425 P.O. Box 22788 Chattanooga, TN 37422 www.propexinc.com</p>
<p>Saint-Gobain Technical Fabrics 1795 Baseline Rd Grand Island, NY 14072-2010 www.glasrid.com</p>	<p>SKAPS Industries 335 Athena Dr Athens, GA 30601 www.nevown.com</p>

Strata Systems, Inc., Div. Glen Raven, Inc. PO Box 791 Statesville, NC 28687-0791 www.geogrid.com	SynTeen Technical Fabrics 1950 W Meeting St Lancaster, SC 29720-8811 www.synteen.com
Tenax Corp. 4800 E Monument St Baltimore, MD 21205-3031	TenCate Geosynthetics 365 S Holland Dr Pendergrass, GA 30567-4625 www.tencate.com
Tensar International Corporation 5883 Glenridge Dr NE Ste 200 Atlanta, GA 30328-5571 www.tensar-international.com	Thrace-LINQ Inc. 2550 W 5th North St Summerville, SC 29483-9665
TNS Advanced Technologies By Crown Resources 856 S Pleasantburg Dr Greenville, SC 29607-2455	Vantage Partners, LLC 1000 Bucks Industrial Park Dr Statesville, NC 28625-2575 www.vp-geos.com
* List is from the Geosynthetics Materials Association.	

1.3 LOAD AND RESISTANCE FACTOR DESIGN (LRFD)

The most significant revision/update of this reference manual is the change of design procedure for MSE walls from an allowable stress design (ASD) basis to load and resistance factor design (LRFD) basis. Transportation superstructures are designed using LRFD procedures, and logically the substructures supporting the superstructures should also be designed on a LRFD basis to provide design consistency on the overall project. Therefore, FHWA and the AASHTO Subcommittee on Bridges and Substructures established an October 1, 2010 deadline for implementation of LRFD in wall design.

Although the implementation of LRFD requires a change in design procedures for engineers accustomed to ASD, many advantages do exist. LRFD separately accounts for uncertainty in both resistance and load, and when appropriately calibrated, can provide more consistent levels of safety in the design of superstructure and substructure components in terms of reliability index. Section 11 of the AASHTO LRFD Specification (2007) provides information on LRFD for earth retaining structures including mechanically stabilized earth (MSE) walls. Section 10.4 of AASHTO (2007) provides detailed information on the evaluation of soil and rock properties to be used for design. Section 3 of AASHTO (2007) provides detailed information on vertical and lateral loads, and load factors for the design of retaining walls.

For many years, engineers have designed walls for highway and other applications using allowable stress design (ASD) methods. (Note that the AASHTO (2002) and FHWA (Elias et al., 2001) ASD references will not be updated by AASHTO or FHWA, respectively.) In

ASD, all uncertainty in applied loads and material resistance are combined in a factor of safety or allowable material stress. Furthermore, the factor of safety is independent of the method used to estimate the resistance. In LRFD, uncertainty in load and material resistance are accounted for separately. The uncertainty in load is represented by a load factor and the uncertainty in material resistance is represented by a resistance factor. More importantly, the resistance factor is a function of the method used to estimate the resistance and thus the model uncertainty is also included in the design process.

In the AASHTO-LRFD framework, there are four limit states, which represent distinct structural performance criteria: (1) strength limit states; (2) serviceability limit states; (3) extreme event limit states; and (4) fatigue limit states. For most earth retaining system designs, the strength or service limit states control the design. For walls subject to earthquake or vessel/vehicle impact, the extreme limit states may control.

This manual, and the accompanying training course curriculum materials, have been prepared assuming that the user is familiar with LRFD general procedures. Agencies can receive detailed training and reference materials on LRFD procedures for substructures from the FHWA NHI 130082 training course (see www.nhi.fhwa.dot.gov).

This manual also provides detailed procedures for the design, specification, and construction of reinforced soil slopes (RSS). The AASHTO LRFD Bridge Design Specifications (2007) do not address RSS structures. Therefore, the design for RSS remains based upon a limit equilibrium slope stability basis within this manual.

CHAPTER 2

SYSTEMS AND PROJECT EVALUATION

This chapter describes available MSE wall (MSEW) and RSS systems and components, their application, advantages, disadvantages and relative costs. Subsequently, it reviews typical construction sequence for MSEW and RSS construction, and outlines required site and project evaluations leading to the establishment of site-specific project criteria and details.

2.1 APPLICATIONS

2.1.1 MSE Walls

MSEW structures are cost-effective alternatives for most applications where reinforced concrete or gravity type walls have traditionally been used to retain soil. These include bridge abutments and wing walls, as well as areas where the right-of-way is restricted, such that an embankment or excavation with stable side slopes cannot be constructed. They are particularly suited to economical construction in steep-sided terrain, in ground subject to slope instability, or in areas where foundation soils are poor.

MSE walls offer significant technical and cost advantages over conventional reinforced concrete retaining structures at sites with poor foundation conditions. In such cases, the elimination of costs for foundation improvements such as piles and pile caps, that may be required for support of conventional structures, have resulted in cost savings of greater than 50 percent on completed projects.

Representative uses of MSE walls for various applications are shown in Figure 2-1.

Temporary MSE wall structures have been especially cost-effective for temporary detours necessary for highway reconstruction projects. Temporary MSE walls are used to support temporary roadway embankments and temporary bridge abutments, as illustrated in Figure 2-2. MSE walls are also used as temporary support of permanent roadway embankments for phased construction, an example is shown in Figure 2-3.

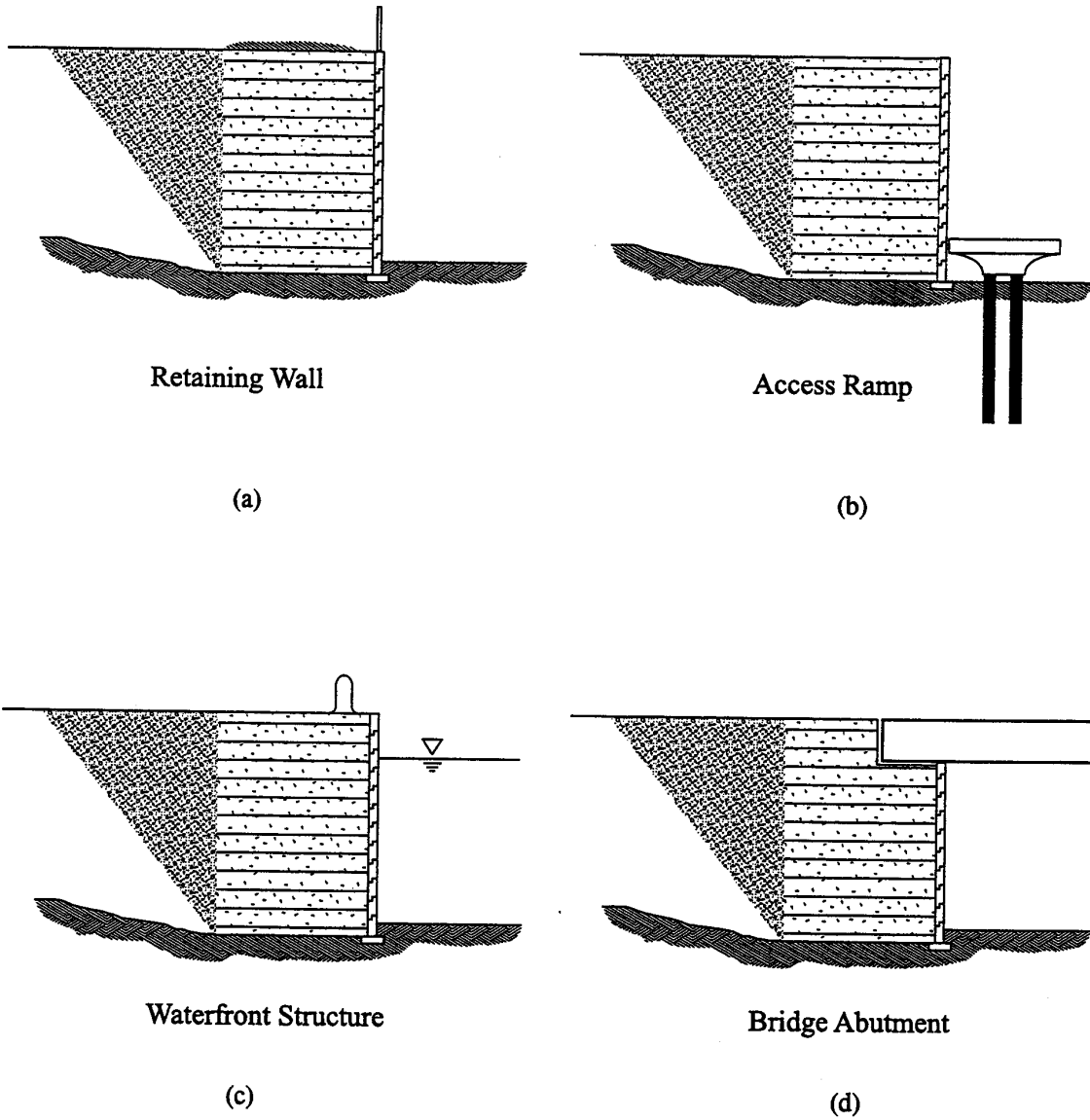

Figure 2-1. Representative MSE wall applications (a) retaining wall; (b) access ramp; (c) waterfront structure; and (d) bridge abutment.



Figure 2-2. MSE walls to support temporary bridge abutment and roadway embankment.



Figure 2-3. MSE wall used to temporarily support a permanent roadway embankment for phased construction.

2.1.2 Reinforced Soil Slopes

Reinforced soil slopes (RSS) are a form of mechanically stabilized earth that incorporate planar reinforcing elements (typically geosynthetics) in constructed earth sloped structures with face inclinations of less than 70 degrees. As shown in Figure 2-4, multiple layers of reinforcement are placed in the slope during construction or reconstruction to reinforce the soil and provide increased slope stability. RSS structures are cost-effective alternatives for new construction and reconstruction where the cost of fill, right-of-way, and other considerations may make a steeper slope desirable.

There are two primary purposes for using reinforcement in engineered slopes.

- To increase the stability of the slope, particularly if a steeper than *safe* unreinforced slope is desirable or after a failure has occurred as shown in Figure 2-4.
- To provide improved compaction at the edges of a slope, thus decreasing the tendency for surface sloughing as shown in Figure 1-2b.

Reinforcement is used to construct an embankment at an angle steeper than could otherwise be safely constructed with the same soil. The increase in stability allows for construction of steepened slopes on firm foundations for new highways and as an alternative to flatter unreinforced slopes and to retaining walls. Roadways can also be widened over existing flatter slopes without encroaching beyond existing right-of-ways. In the case of repairing a slope failure, the new slope will be safer, and reusing the slide debris rather than importing higher quality backfill may result in substantial cost savings. These applications are illustrated in Figure 2-4.

The second purpose for using reinforcement is at the edges of a compacted fill slope to provide lateral resistance during compaction. The increased lateral resistance allows for an increase in compacted soil density over that normally achieved and provides increased lateral confinement for the soil at the face. Even modest amounts of reinforcement in compacted slopes have been found to prevent sloughing and reduce slope erosion. Edge reinforcement also allows compaction equipment to more safely operate near the edge of the slope.

Further compaction improvements have been found in cohesive soils through the use of geosynthetics with in-plane drainage capabilities (e.g., nonwoven geotextiles) that allow for rapid pore pressure dissipation in the compacted soil.

Compaction aids placed as intermediate layers between reinforcement in steepened slopes may also be used to provide improved face stability and to reduce layers of more expensive primary reinforcement as shown in Figure 1-2.

Other applications of reinforced slopes have included:

- Decreased bridge spans.
- Temporary road widening for detours.
- Prevention of surface sloughing during periods of saturation.
- Embankment construction with wet, fine-grained soils.
- Permanent levees.
- Temporary flood control structures.

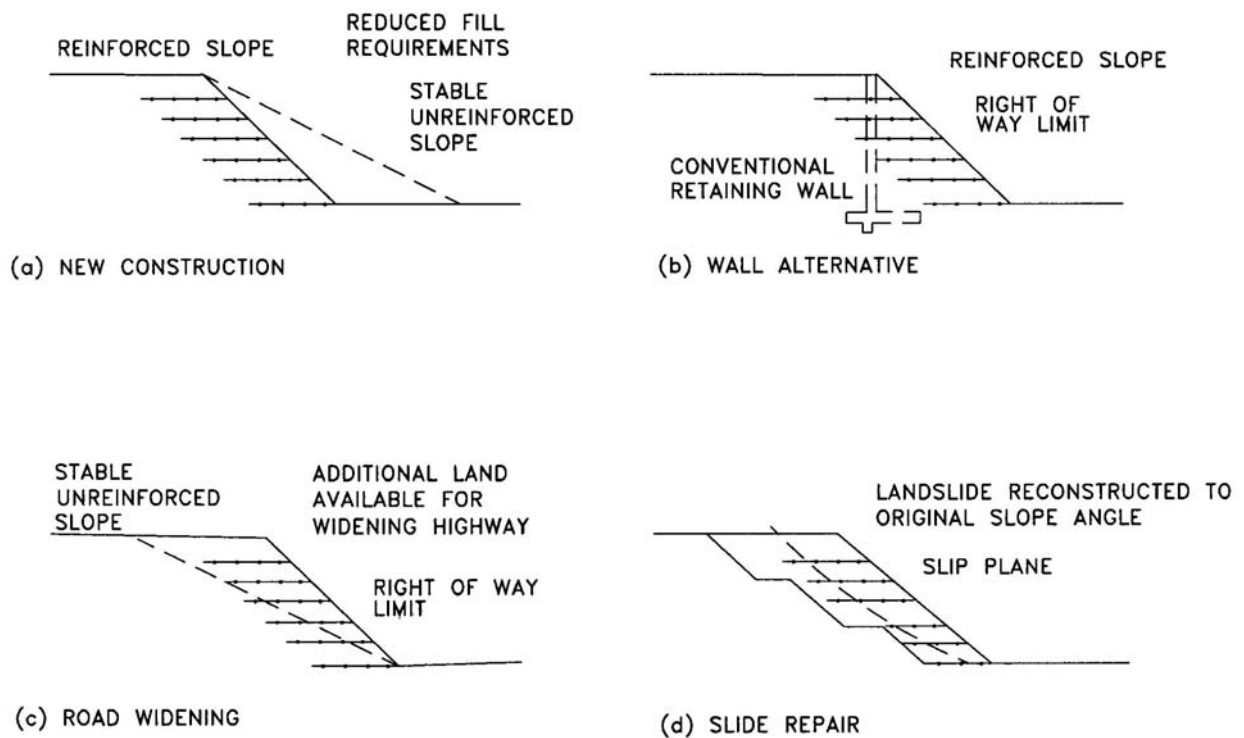

Figure 2-4. Application of reinforced soil slopes.

2.2 ADVANTAGES AND POTENTIAL DISADVANTAGES

2.2.1 Advantages of Mechanically Stabilized Earth (MSE) Walls

MSE walls have many advantages compared with conventional reinforced concrete and concrete gravity retaining walls. MSE walls:

- Use simple and rapid construction procedures and do not require as large of construction equipment.
- Do not require special skills for construction.
- Require less site preparation than other alternatives.
- Need less space in front of the structure for construction operations.
- Reduce right-of-way acquisition.
- Do not need rigid, unyielding foundation support because MSE structures are tolerant to deformations.
- Are cost effective.
- Are technically feasible to heights in excess of 100 ft (30 m).

Pre-manufactured materials, rapid construction, and, competition among different proprietary systems has resulted in a cost reduction relative to traditional types of retaining walls. MSE walls are likely to be more economical than other wall systems for walls higher than about 10 ft (3 m) or where special foundations would be required for a conventional wall.

One of the greatest advantages of MSE walls is their flexibility and capability to tolerate deformations due to poor subsoil foundation conditions. Also, based on observations in seismically active zones, these structures have demonstrated a higher resistance to seismic loading than rigid concrete wall structures.

Precast concrete facing elements for MSE walls can be made with various shapes and textures (with little extra cost) for aesthetic considerations. Masonry units, timber, and gabions also can be used to blend in the environment.

2.2.2 Advantages of Reinforced Soil Slopes (RSS)

The economic advantages of constructing a safe, steeper RSS than would normally be possible are the result of material and right-of-way savings. It also may be possible to decrease the quality of materials required for construction. For example, in repair of landslides it is possible to reuse the slide debris rather than to import higher quality backfill. Right-of-way savings can be a substantial benefit, especially for road widening projects in urban areas where acquiring new right-of-way is always expensive and, in some cases,

unobtainable. RSS also provide an economical alternative to retaining walls. In some cases, reinforced slopes can be constructed at about one-half the cost of MSEW structures.

The use of vegetated-faced reinforced soil slopes that can be landscaped to blend with natural environments may also provide an aesthetic advantage over retaining wall structures. However, there are some potential maintenance issues that must be addressed such as mowing grass-faced steep slopes; however, these can be satisfactorily handled in design.

In terms of performance, due to inherent conservatism in the design of RSS, they are actually safer than flatter, unreinforced slopes designed at the same factor of safety. As a result, there is a lower risk of long-term stability problems developing with a reinforced slope. Such problems often occur in compacted fill slopes that have been constructed to low factors of safety and/or with marginal materials (e.g. deleterious soils such as shale, fine grained low cohesive silts, plastic soils, etc.). The reinforcement may also facilitate strength gains in the soil over time from soil aging and through improved drainage, further improving long-term performance.

2.2.3 Potential Disadvantages

The following general potential disadvantages may be associated with all reinforced soil structures, and are dependent upon local and project conditions:

- Require a relatively large space (e.g., excavation if in a cut) behind the wall or slope face to install required reinforcement.
- MSE walls require the use of select granular fill. (At some sites, the cost of importing suitable fill material may render the system uneconomical.) Reinforced fill requirements for RSS are typically less restrictive.
- The design of soil-reinforced systems often requires a shared design responsibility between material suppliers and owners.

2.3 RELATIVE COSTS

Site specific costs of a soil-reinforced structure are a function of many factors, including cut-fill requirements, wall/slope size and type, in-situ soil type, available backfill materials, facing finish, temporary or permanent application, etc. It has been found that MSE walls with precast concrete facings are usually less expensive than reinforced concrete retaining

walls for heights greater than about 10 ft (3 m) and average foundation conditions. Modular block wall (MBW) unit faced walls are competitive with concrete walls at all heights and also for small projects.

In general, the use of MSE walls results in savings on the order of 25 to 50 percent and possibly more with a conventional reinforced concrete retaining structure, especially when the latter is supported on a deep foundation system (poor foundation condition). A substantial savings is obtained by elimination of the deep foundations, which is usually possible because reinforced soil structures can accommodate relatively large total and differential settlements. Other cost saving features include ease of construction and speed of construction. Typical total costs for permanent transportation MSE walls range from \$30 to \$65 per ft² (\$320 to \$650 per m²) of face, and generally vary as function of height, size of project, aesthetic treatment, site accessibility, and cost of select wall fill. However, reinforced fill costs vary considerably across the U.S. and regional costs may be much higher than the indicated range (not just for MSE walls, but for other wall types as well). Some example costs are presented with the case histories in Section 2.10.

The actual cost of a specific MSEW structure will depend on the cost of each of its principal components. For segmental precast concrete faced structures, typical relative costs are:

- Erection of panels and contractors profit - 20 to 30 percent of total cost.
- Reinforcing materials - 15 to 30 percent of total cost.
- Facing system - 20 to 40 percent of total cost.
- Reinforced wall fill including placement - 30 to 60 percent of total cost, where the fill is a select granular fill from an off-site borrow source.

The additional cost for panel architectural finish treatment ranges from \$0.50 to \$1.50 per ft² (\$5 to \$15 per m²) depending on the complexity of the finish. Traffic barrier costs average \$170 per linear foot (\$550 per linear m). In addition, consideration must be given to the cost of excavation, which may be somewhat greater than for other systems due to the required width of the reinforcement zone. MBW faced walls at heights less than 15 ft (4.5 m) are typically less expensive than segmental panel faced walls by 10 percent or more.

The economy of using RSS must be assessed on a case-by-case basis, where use is not dictated by space constraints. For such cases, an appropriate benefit to cost ratio analysis should be conducted to determine whether a steeper slope with the reinforcement is justified economically over the alternative flatter slope with its increased right-of-way and materials costs, etc. It should be kept in mind that guardrails or traffic barriers are often necessary for steeper embankment slopes and additional costs such as erosion control systems for slope face protection must be considered.

With respect to economy, the factors to consider are as follows:

- Cut or fill earthwork quantities.
- Size of slope area.
- Average height of slope area.
- Angle of slope.
- Cost of nonselect versus select backfills.
- Temporary and permanent erosion protection requirements.
- Cost and availability of right-of-way needed.
- Complicated horizontal and vertical alignment changes.
- Need for temporary excavation support systems.
- Maintenance of traffic during construction.
- Aesthetics.
- Requirements for guardrails and traffic barriers.

The actual bid cost of a specific RSS structure depends on the cost of each of its principal components. Based on limited data, typical relative costs are:

- Reinforcement - 45 to 65 percent of total cost
- Reinforced fill - 30 to 50 percent of total cost
- Face treatment - 5 to 10 percent of total cost

High RSS structures have relatively higher reinforcement and lower backfill costs. Recent bid prices suggest costs ranging from \$10/ft² to \$24/ft² (\$110/m² to \$260/m²) as a function of height.

For applications in the 30 to 50 ft (10 to 15 m) height range, bid costs of about \$16/ft² (\$170/m²) have been reported. These prices do not include safety features and drainage details.

A rapid, first-order assessment of cost items for comparing a flatter unreinforced slope with a steeper reinforced slope is presented in Figure 2-5.

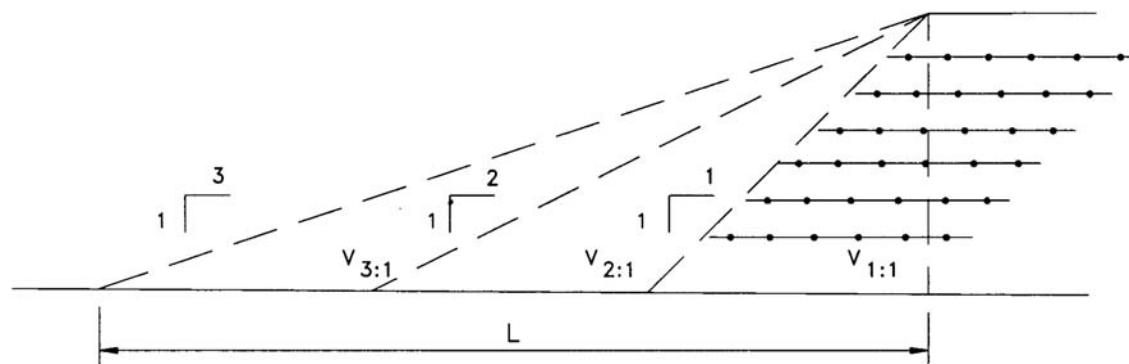

$$\begin{array}{ll} V_{3:1} = V & V_{3:1} = L \\ V_{2:1} = \frac{2}{3}V & V_{2:1} = \frac{2}{3}L \\ V_{1:1} = \frac{1}{3}V & V_{1:1} = \frac{1}{3}L \end{array}$$

COST:

$$\begin{array}{l} 3H:1V = V_{\text{SOIL}} + L_{\text{LAND}} + \text{Guardrail* (?) + Hydroseeding (?)} \\ 2H:1V = \frac{2}{3}V_{\text{SOIL}} + \frac{2}{3}L_{\text{LAND}} + \text{Guardrail + Erosion Control + High Maintenance} \\ 1H:1V = \frac{1}{3}V_{\text{SOIL}} + \frac{1}{3}L_{\text{LAND}} + \text{Reinforcement + Guardrail + Erosion Control} \end{array}$$

* Include guardrail or traffic barrier cost if required.

Figure 2-5. Cost evaluation of reinforced soil slopes.

2.4 DESCRIPTION OF MSE and RSS SYSTEMS

2.4.1 Systems Differentiation

Since the expiration of the fundamental process and concrete facing panel patents obtained by the Reinforced Earth Company for MSE wall systems and structures, the engineering community has adopted a generic term *Mechanically Stabilized Earth* (MSE) to describe this type of retaining wall construction.

Trademarks, such as Reinforced Earth[®], Retained Earth[®], Genesis[®] etc., describe systems with some present or past proprietary features or unique components marketed by nationwide commercial suppliers. Other trademark names appear yearly to differentiate systems marketed by competing commercial entities that may include proprietary or novel components or for special applications.

A system for either MSEW or RSS structures is defined as a complete supplied package that includes design, specifications and all prefabricated materials of construction necessary for

the complete construction of a reinforced soil structure. Often technical assistance during the planning and construction phase is included. Components marketed by commercial entities for integration by the owner, or others, into a coherent package are not classified as systems. Generic systems created by combining components are also possible; however, the components must be tested and evaluated together in the form of the final system. Components cannot be substituted without complete evaluation of the impact on the system.

2.4.2 Types of Systems

MSE/RSS systems can be described by the reinforcement geometry, stress transfer mechanism, reinforcement material, extensibility of the reinforcement material, and the type of facing and connections.

Reinforcement Geometry Three types of reinforcement geometry can be considered:

- **Linear unidirectional.** Strips, including smooth or ribbed steel strips, or coated geosynthetic strips over a load-carrying fiber.
- **Composite unidirectional.** Grids or bar mats characterized by grid spacing greater than 6 in. (150 mm).
- **Planar bi-directional.** Continuous sheets of geosynthetics, welded wire mesh, and woven wire mesh. The mesh is characterized by element spacing of less than 6 in. (150 mm).

Reinforcement Material Distinction can be made between the characteristics of metallic and nonmetallic reinforcements:

- **Metallic reinforcements.** Typically of mild steel. The steel is usually galvanized.
- **Nonmetallic reinforcements.** Generally polymeric materials consisting of polyester or polyethylene.

The performance and durability considerations for these two classes of reinforcement vary considerably and are detailed in the companion Corrosion/Degradation manual (FHWA NHI-09-087; Elias et al., 2009).

Reinforcement Extensibility There are two classes of extensibility relative to the soil's extensibility:

- **Inextensible.** The deformation of the reinforcement at failure is much less than the deformability of the soil. Steel strip and bar mat reinforcements are inextensible.
- **Extensible.** The deformation of the reinforcement at failure is comparable to or even greater than the deformability of the soil. Geogrid, geotextile, and woven steel wire mesh reinforcements are extensible.

2.4.3 Facing Systems

The types of facing elements used in the different MSE systems control their aesthetics because they are the only visible parts of the completed structure. A wide range of finishes and colors can be provided in the facing, as shown in the FHWA Federal Lands Highway Division's Roadway Aesthetic Treatments Photo Album (RATPA) available at <http://gallery.companys39.com/FLH/gallery/>. In addition, the facing provides protection against backfill sloughing and erosion, and provides, in certain cases, drainage paths. The type of facing influences settlement tolerances. Major facing types are:

- **Segmental precast concrete panels.** The various shapes and dimensions of segmental precast panels are summarized in Table 1-1, and examples are illustrated in Figure 2-6 (and in Figure 5-33). The precast concrete panels have a minimum thickness of 5-½ inches (140 mm) and are of a square, rectangular, cruciform, diamond, or hexagonal geometry. Typical nominal panel dimensions are 5-foot (1.5 m) high and 5- or 10-foot (1.5 or 3 m) wide. Temperature and tensile reinforcement of the concrete are required and should be designed in accordance with Section 5 of AASHTO LRFD Specifications for Highway Bridges (2007).
- **Dry cast modular block wall (MBW) units.** These are relatively small, squat concrete units that have been specifically designed and manufactured for retaining wall applications. The weight of these units commonly ranges from 30 to 110 lbs (15 to 50 kg), with units of 75 to 110 lbs (35 to 50 kg) routinely used for highway projects. Unit heights typically range from 4 to 12 in. (100 to 300 mm) for the various manufacturers, with 8-in. (200 mm) typical. Exposed face length usually varies from 8 to 18 in. (200 to 450 mm). Nominal front to back width (dimension perpendicular to the wall face) of units typically ranges between 8 and 24 in. (200 and 600 mm). Units may be manufactured solid or with cores. Full height cores are filled with aggregate during erection. Units are normally dry-stacked (i.e. without mortar or bearing pads) and in a running bond configuration. Vertically adjacent units may be connected with shear pins, lips, or keys. They are referred to by trademarked names such as Keystone[®], Landmark[®], Mesa[®], Versa-Lok[®], etc. Several example MBW units are illustrated in Figure 2-7.
- **Welded Wire Mesh (WWM).** Wire grid can be bent up at the front of the wall to form the wall face. This type of facing is used for example in the Hilfiker, Tensar, and Reinforced Earth wire faced retaining wall systems. This type of facing is commonly used for RSS with face angles of about 45 degrees and steeper.

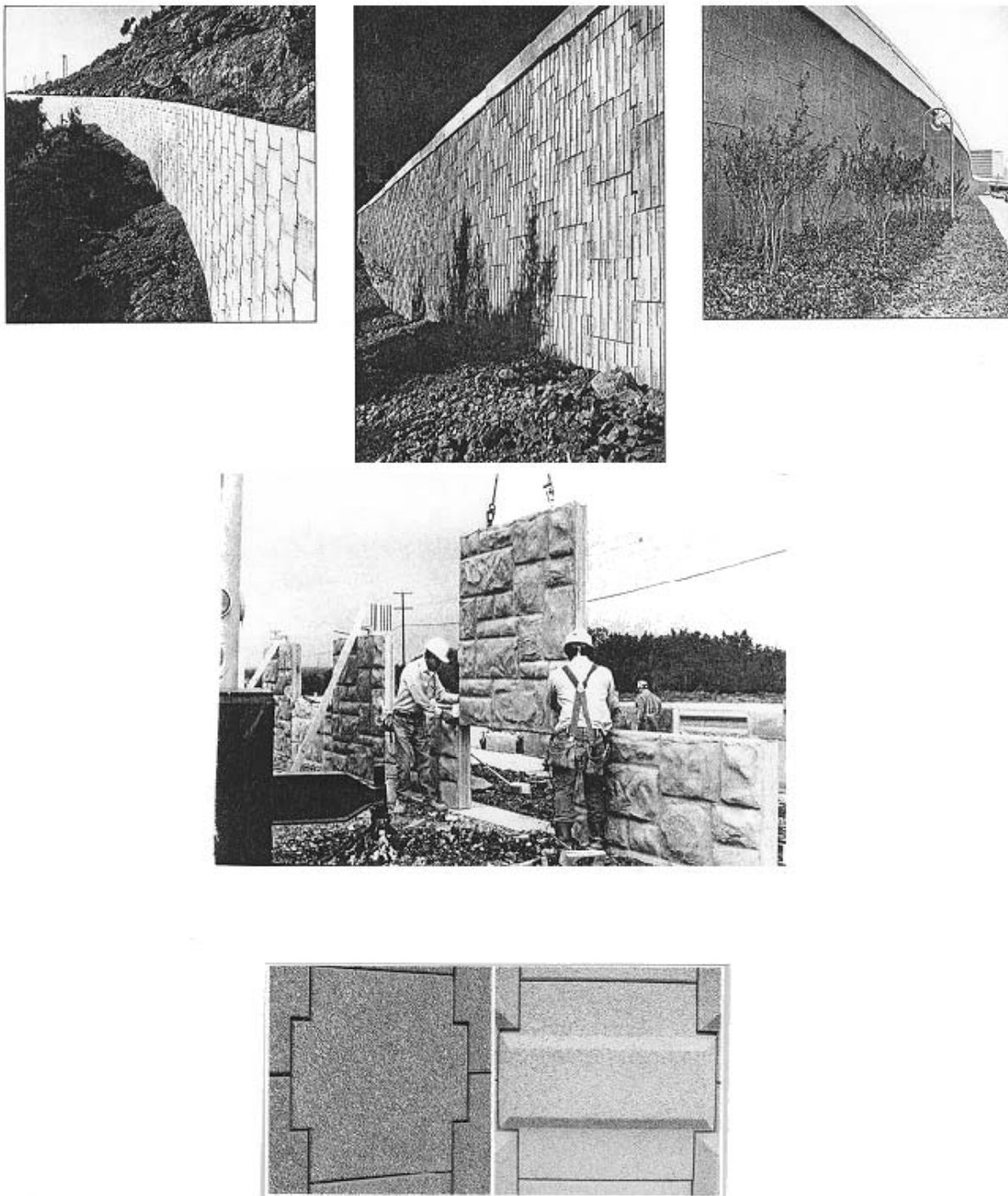
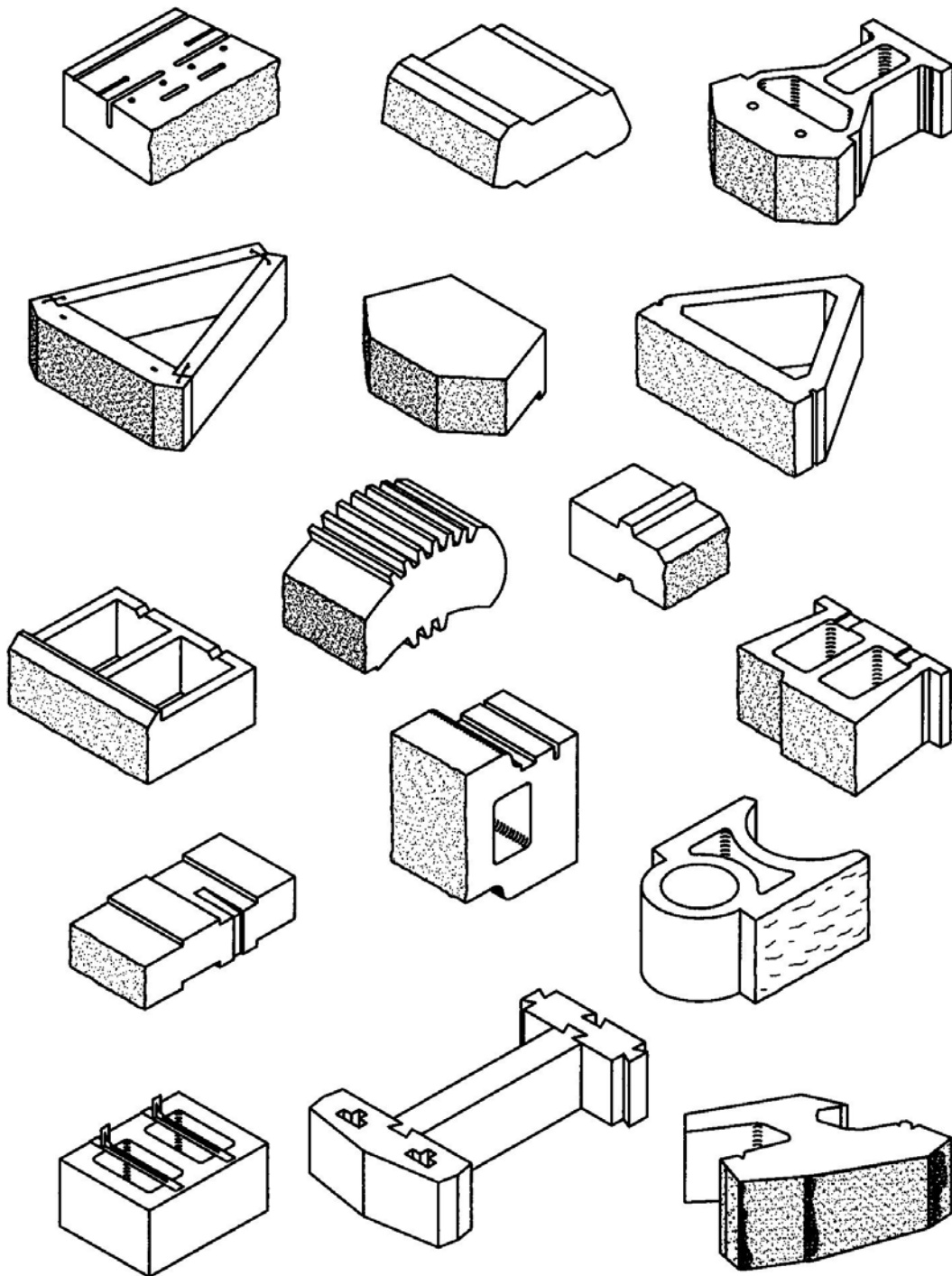

Figure 2-6. Example MSE wall facing treatments.
 (See Figure 5-33 and <http://gallery.company39.com/FLH/gallery/> for additional example facings.)



**NOTE: THE UNITS PRESENTED ARE PROPRIETARY AND/OR
PATENTED SYSTEMS**

Figure 2-7. Examples of commercially available MBW units (NCMA, 1997).

- **Gabion Facing.** Gabions (rock-filled wire baskets) can be used as MSE wall or RSS facing with reinforcing elements consisting of welded wire mesh, welded bar-mats, geogrids, geotextiles or the double-twisted woven mesh placed between or integrally manufactured with the gabion baskets. For example, this facing system is used by Maccaferri for their Terramesh® wall system.
- **Geosynthetic Facing.** Geosynthetic reinforcements are looped around at the facing to form the exposed face of the MSEW or RSS. These faces are susceptible to ultraviolet light degradation, vandalism, and damage due to fire. Geogrid used for soil reinforcement can be looped around to form the face of the completed retaining structure in a similar manner to welded wire mesh and fabric facing. Vegetation can grow through the grid structure and can provide both ultraviolet light protection for the geogrid and a pleasing appearance.
- **Post-construction Facing.** For wrapped faced walls, the facing – whether geotextile, geogrid, or wire mesh – can be attached after construction of the wall by shotcreting, guniting, cast-in-place concrete or by attaching prefabricated facing panels made of concrete, wood, or other materials. This multi-staging facing approach adds cost but is advantageous where significant settlement is anticipated.

Precast elements can be cast in several shapes and provided with facing textures to match environmental requirements and blend aesthetically into the environment. Retaining structures using precast concrete elements as the facings can have surface finishes similar to any reinforced concrete structure.

Retaining structures with metal facings have the disadvantage of shorter life because of corrosion, unless provision is made to compensate for it. Facings using welded wire or gabions have the disadvantages of an uneven surface, exposed backfill materials, more tendency for erosion of the retained soil, possible shorter life from corrosion of the wires, and more susceptibility to vandalism. These disadvantages can, of course, be countered by providing shotcrete or by hanging facing panels on the exposed face and compensating for possible corrosion with galvanization and thicker wire. The greatest advantages of such facings are low cost, ease of installation, design flexibility, good drainage (depending on the type of wall fill) that provides increased stability, and possible treatment of the face for vegetative and other architectural effects. The facing can easily be adapted and well blended with natural country environment. These facings, as well as geosynthetic wrapped facings, are especially advantageous for construction of temporary or other structures with a short-term design life.

Dry cast segmental block MBW facings may raise some concerns as to durability in aggressive freeze-thaw environments where deicing salts are used. Recent research has shown that the MBW mix design must be specifically formulated to produce durable, freeze-thaw resistant units. Agencies should confirm locally manufactured units resistance with laboratory freeze-thaw testing. The current specifications in Chapter 10 have been developed to address this issue. Further, because the cement is not completely hydrated during the dry cast process, (as is often evidenced by efflorescence on the surface of units), a highly alkaline regime may establish itself at or near the face area, and may limit the use of some geosynthetic products as reinforcements.

The slope face of RSS structures is usually vegetated if approximately 1:1 or flatter. The vegetation requirements vary by geographic and climatic conditions and are therefore, project specific. Details are outlined in Section 10.5.

2.4.4 Reinforcement Types

Most, although not all, MSE wall systems with precast concrete panels use steel reinforcements that are typically galvanized. The two types of steel reinforcements currently in use with segmental panel faced MSE walls are:

1. Steel strips. The currently commercially available strips are ribbed top and bottom, 2 in. (50 mm) wide and 5/32-inch (4 mm) thick. Smooth strips 2- to 4³/₄-in. (60 to 120 mm) wide, 1/8 to 5/32-inch (3 to 4 mm) thick have been used.
2. Steel grids. Welded wire grid using two to six W7.5 to W24 longitudinal wire spaced at either 6 or 8 in. (150 or 200 mm). The transverse wire may vary from W11 to W20 and are spaced based on design requirements from 9 to 24 in. (230 to 600 mm). Welded steel wire mesh spaced at 2 by 2-inch (50 by 50 mm) of thinner wire has been used in conjunction with a welded wire facing. Some MBW systems use steel grids with two longitudinal wires.

Most MBW systems use geosynthetic reinforcement, predominantly geogrids. The following soil reinforcement types are widely used and available:

3. High Density Polyethylene (HDPE) geogrid. These are of uniaxial manufacture and are available in up to 6 grades of strength. This type of reinforcement is also used with segmental panel facing.

4. PVC coated polyester (PET) geogrid. Available from a number of manufacturers. They are characterized by bundled high tenacity PET fibers in the longitudinal load carrying direction. For longevity the PET is supplied as a high molecular weight fiber and is further characterized by a low carboxyl end group number.

Other types of soil reinforcements, and their applications, include:

5. Geotextiles. High strength geotextiles can be used principally in connection with reinforced soil slope (RSS) construction. Both polyester (PET) and polypropylene (PP) geotextiles have been used.
6. Double twisted steel mesh. The Terramesh[®] system by Maccaferri, Inc. uses a metallic, soft-temper, double twisted mesh soil reinforcement that is galvanized and then coated with poly vinyl chloride (PVC). This reinforcement is used for RSS and gabion faced MSE wall construction. Note that this reinforcement is classified as an *extensible* type of reinforcement due to its manufacturing geometry even though it is metallic.
7. Geosynthetic strap. Although not (currently) widely used, a geosynthetic strap type reinforcement has been used with segmental panel faced MSE walls. The strap consists of PET fibers encased in a polyethylene (PE) sheath.

2.4.5 Reinforced Fill Materials

MSEW Structures MSE walls require high quality wall fill for durability, good drainage, constructability, and good soil reinforcement interaction which can be obtained from well graded, granular materials. Many MSE systems depend on friction between the reinforcing elements and the soil. In such cases, a material with high friction characteristics is specified and required. Some systems rely on passive pressure on reinforcing elements, and, in those cases, the quality of reinforced wall fill is still critical. These performance requirements generally eliminate soils with high clay contents.

From a reinforcement capacity point of view, lower quality wall fills could be used for MSEW structures; however, a high quality granular wall fill has the advantages of better drainage, providing better durability for metallic reinforcement, and requiring less reinforcement. There are also significant handling, placement and compaction advantages in using granular soils. These include an increased rate of wall erection and improved maintenance of wall alignment tolerances. Appropriate use of lower quality reinforced fill and design considerations for its use is discussed in Chapter 3.

RSS Structures Reinforced Soil Slopes are normally not constructed with rigid facing elements. Slopes constructed with a flexible face can thus readily tolerate minor distortions that could result from settlement, freezing and thawing, or wetting-drying of the backfill. As a result, any soil meeting the requirements for embankment construction could be used in a reinforced slope system. However, a higher quality material offers fewer durability concerns for the reinforcement, and is easier to handle, place and compact, which speeds up construction.

2.4.6 Appurtenant Materials of Construction

Walls using precast concrete panels require bearing pads in their horizontal joints that provide some compressibility and movement between panels during elastic compression and settlement of the reinforced fill and preclude concrete-to-concrete contact. These materials are generally EPDM rubber or HDPE. The compressibility and thickness of the horizontal joint material should be a function of the wall height. Walls with heights greater than 50 ft (15 m) may require thicker or more compressible joints to accommodate the larger vertical loads due to the weight of panels in the lower third of the structure.

All joints of precast concrete panels are covered with a geotextile filter strip to prevent the migration of fines from the reinforced wall fill.

Bearing pads are not routinely used with MBW units. A zone of aggregate fill, usually 1-ft wide, is used behind the MBW units and within units with cores. This gravel readily compacted and conforms to the MBW unit. A filter is required between the gravel zone and wall fill, and can either be a soil filter or a geotextile filter (see Chapter 5).

2.5 CONSTRUCTION SEQUENCE

The following is an outline of the principal sequence of construction for MSEW and RSS. Specific systems, special appurtenances and specific project requirements may vary from the general sequence indicated.

2.5.1 Construction of MSEW systems with precast panel facings

The construction of MSEW systems with a precast panel facing is carried out as follows:

- **Preparation of subgrade.** This step involves removal of unsuitable materials from the area to be occupied by the retaining structure. All organic matter, vegetation, slide debris and other unstable materials should be stripped off and the subgrade compacted.

In unstable foundation areas, ground improvement methods, such as excavation and replacement, or dynamic compaction, stone columns, wick drains, etc. (see FHWA NHI-06-019 and NHI-06-020, Elias et al., 2006) would be constructed prior to wall erection.

- **Placement of a leveling pad for the erection of the facing elements.** This generally unreinforced concrete pad is often only 1 ft (300 mm) wide and 6 in. (150 mm) thick and is used for MSEW construction only, where concrete panels are subsequently erected. A wider concrete pad is recommended for MBW unit erection.

The purpose of this pad is to serve as a guide for facing panel erection and is not intended as a structural foundation support.

- **Erection of the first row of facing panels on the prepared leveling pad.** Facings may consist of either precast concrete panels or dry cast MBW units.

The first row of facing panels may be full, or half-height panels, depending upon the type of facing used. Only the first tier of panels must be braced to maintain stability and alignment. Subsequent rows of panels are simply wedged and clamped to adjacent panels. For construction with MBW units, full sized blocks are used throughout with no shoring.

The erection of facing panels and placement of the soil backfills should proceed simultaneously.

- **Placement and compaction of reinforced wall fill on the subgrade to the level of the first layer of reinforcement and its compaction.** The fill should be compacted to the specified density, usually 95 to 100 percent of AASHTO T-99 maximum density and within the specified range of optimum moisture content. Compaction moisture contents dry of optimum are recommended.

A key to good performance is *consistent* placement and compaction. Wall fill lift thickness must be controlled based on specification requirements and vertical distribution of reinforcement elements. The uniform loose lift thickness of the reinforced backfill should not exceed 12 in. (300 mm). Reinforced wall fill should be dumped into or parallel to the rear and middle of the reinforcement and bladed toward the front face.

Retained backfill placement and compaction behind the reinforced volume should proceed simultaneously.

- **Placement of the first layer of reinforcing elements on the wall fill.** The reinforcements are placed and connected to the facing panels, when the compacted fill has been brought up to the level of the connection. The reinforcements are generally placed perpendicular to back of the facing panels. More detailed construction control procedures associated with each construction step are outlined in Chapter 11.
- **Placement of the wall fill over the reinforcing elements to the level of the next reinforcement layer and compaction of the wall fill.** The previously outlined steps are repeated for each successive layer.
- **Construction of traffic barriers and copings.** This final construction sequence is undertaken after the final panels have been placed, and the wall fill has been completed to its final grade.

A complete sequence is illustrated in Figures 2-8 through 2-10.

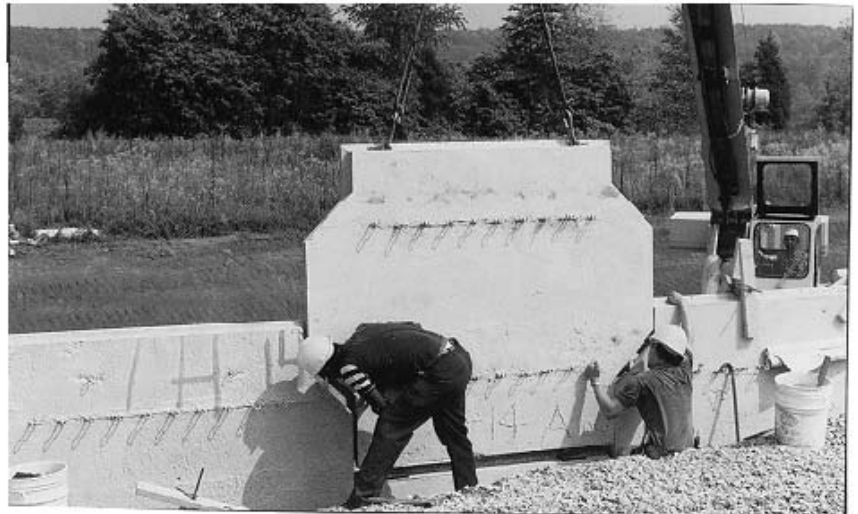

Figure 2-8. Erection of precast panels.

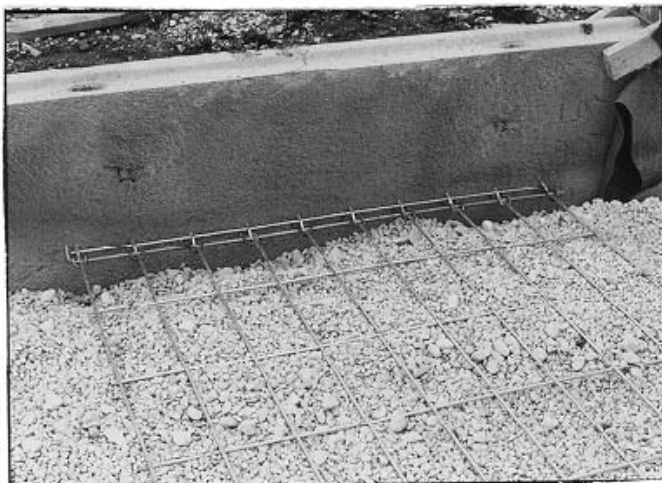

Figure 2-9. Fill spreading and reinforcement connection.



Figure 2-10. Compaction of the reinforced wall fill.

2.5.2 Construction of MSE systems with Flexible Facings

Construction of flexible-faced MSE walls, where the reinforcing material also serves as facing material, is similar to that for walls with precast facing elements. For flexible facing types such as welded wire mesh, geotextiles, geogrids or gabions, the erection of the first level of facing element requires only a level grade. A concrete footing or leveling pad is not usually required unless precast elements are to be attached to the system after construction.

Construction proceeds as outlined for segmental facings with the following exceptions:

- **Placement of first reinforcing layer.** Reinforcement with anisotropic strength properties (i.e., many geosynthetics) should be placed with the principal strength direction perpendicular to face of structure.

The reinforcement should be secured with retaining pins to prevent movement during reinforced fill placement.

Adjacent sheets should be overlapped a minimum of 6 in. (150 mm) along the edges perpendicular to the face. Alternatively, with geogrid or wire mesh reinforcement, the edges may be butted and clipped or tied together.

- **Face Construction.** Place the geosynthetic layers using face forms as shown in Figure 2-11. For temporary support of forms at the face, form holders should be placed at the base of each layer at approximately 4 ft (1.20 m) horizontal intervals. Details of temporary formwork are shown in Figure 2-12. These supports are essential for achieving good compaction. When using geogrids or wire mesh, it may be necessary to use a geotextile or hardware cloth to retain the wall fill material at the face.

When compacting wall fill within 3 ft (~1 m) of the wall face, a hand-operated vibratory compactor is recommended.

The return-type method or successive layer tie method as shown in Figure 2-12 can be used for facing support. In the return method, the reinforcement is folded at the face over the wall fill material, with a minimum return length of 4 ft (1.25 m) to ensure adequate pullout resistance. Consistency in face construction and compaction is essential to produce a wrapped facing with satisfactory appearance.

Apply facing treatment (shotcrete, precast facing panels, etc.). Some alternative facing systems for flexible faced walls and slopes are shown in Figure 2-13.

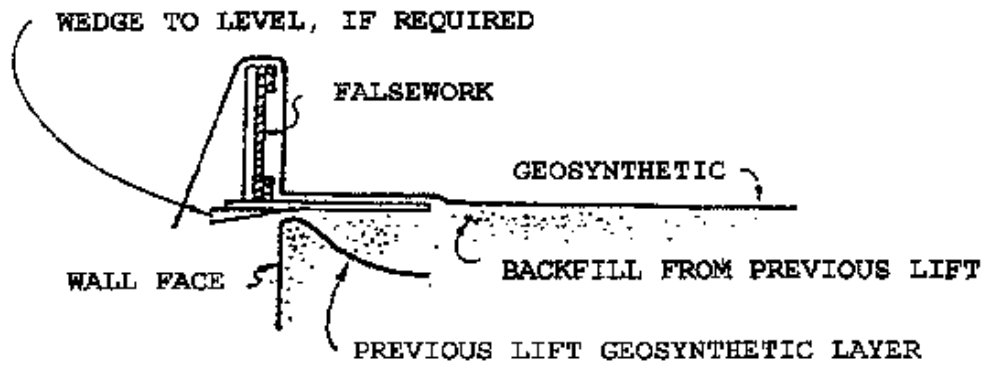

(1) PLACE FALSEWORK AND GEOSYNETHIC ON PREVIOUS LIFT

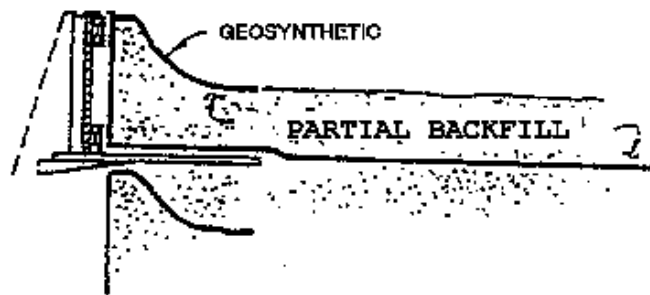

(2) PLACE/COMPACT PARTIAL BACKFILL AND OVERLAP GEOSYNETH

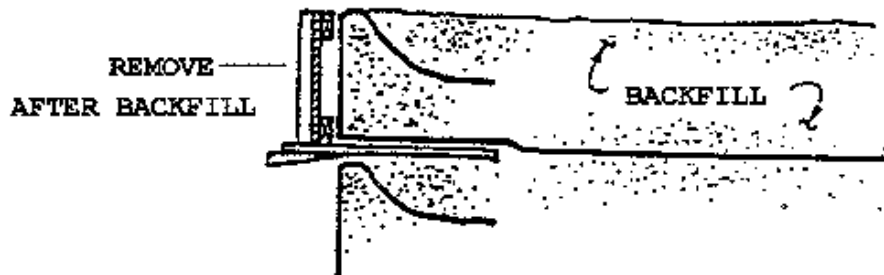

(3) PLACE/COMPACT REMAINDER OF BACKFILL LIFT

Figure 2-11. Lift construction sequence for geosynthetic faced MSE walls.

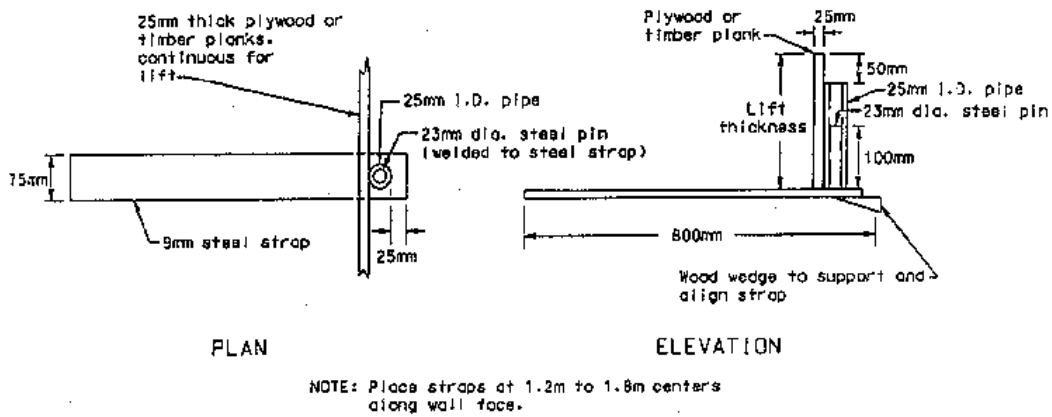

GEOTEXTILE TEMPORARY FORM SYSTEM DETAIL

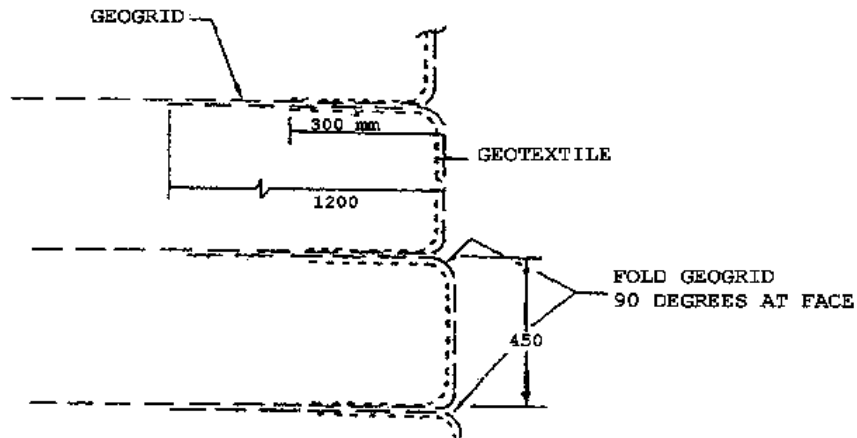
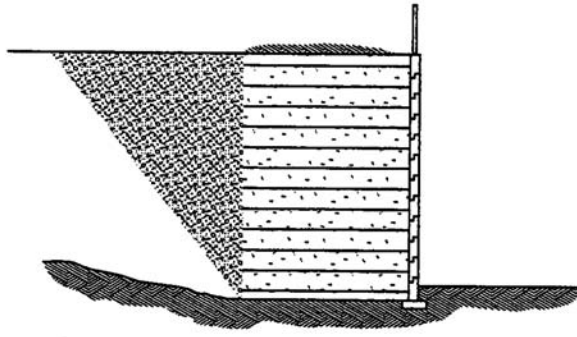
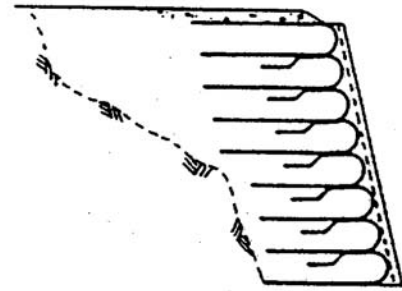

Figure 2-12. Typical geosynthetic face construction detail.
(25 mm = 1 in.)



**Segmental
Precast Concrete**



**Geotextile
Wrapped-Facing
with Shotcrete Cover**

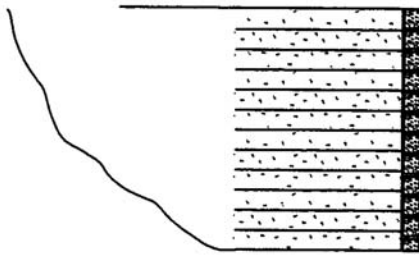

Modular Block Wall Units

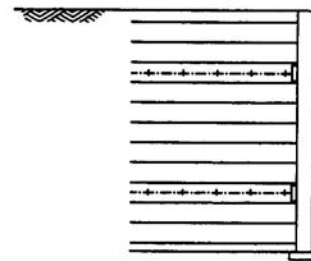

Full-Height Concrete Panel

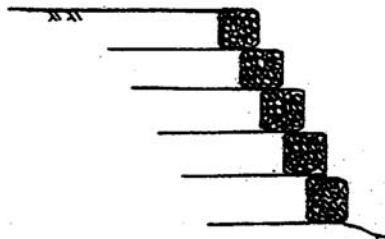

Gabion-Facing

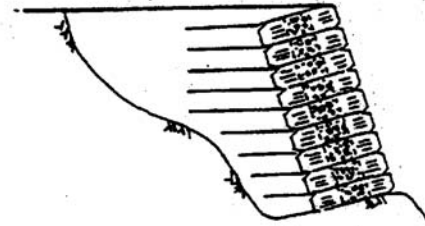

Tire-Facing Units

Figure 2-13. Types of geosynthetic reinforced soil wall facing (after Wu, 1994).

2.5.3 RSS Construction

The construction of RSS embankments is considerably simpler and consists of many of the elements outlined for MSEW construction. They are summarized as follows:

- Site preparation.
- Construct subsurface drainage features.
- Place reinforcement layer.
- Place and compact backfill on reinforcement.
- Construct face. Details of the available methods are outlined in Chapter 8, construction.
- Place additional reinforcement and reinforced fill.
- Construct surface drainage features.

Key stages of construction are illustrated in Figure 2-14, and the complete sequence is fully outlined in Chapter 8.

2.6 SITE EVALUATION

2.6.1 Site Exploration

The feasibility of using an MSEW, RSS or any other type of earth retention system depends on the existing topography, subsurface conditions, and soil/rock properties. It is necessary to perform a comprehensive subsurface exploration program to evaluate site stability, settlement potential, need for drainage, etc., before repairing a slope or designing a new retaining wall or bridge abutment. Where the select backfill is to be obtained from on-site sources, the extent and quality must be fully explored to minimize contractor claims for changed conditions.

Subsurface investigations are required not only in the area of the construction but also behind and in front of the structure to assess overall performance behavior. The subsurface exploration program should be oriented not only towards obtaining all the information that could influence the design and stability of the final structure, but also to the conditions which prevail throughout the construction of the structure, such as the stability of temporary construction slopes that may be required.

The engineer's concerns include the bearing resistance of the foundation materials, the allowable deformations, and the stability of the structure. Necessary parameters for these analyses must be obtained.



Figure 2-14. Reinforced slope construction: (a) geogrid and fill placement; (b) soil filled erosion control mat placement; and (c) finished, vegetated 1:1 slope.

The cost of a reinforced soil structure is greatly dependent on the availability of the required type of reinforced fill and retained backfill materials. Therefore, investigations must be conducted to locate and test locally available materials that may be used for reinforced fill and retained backfill with the selected system.

2.6.2 Field Reconnaissance

Preliminary subsurface investigation or reconnaissance should consist of collecting any existing data relating to subsurface conditions and making a field visit to obtain data on:

- Limits and intervals for topographic cross sections.
- Access conditions for work forces and equipment.
- Surface drainage patterns, seepage, and vegetation characteristics.
- Surface geologic features, including rock outcrops and landforms, and existing cuts or excavations that may provide information on subsurface conditions.
- The extent, nature, and locations of existing or proposed below-grade utilities and substructures that may have an impact on the exploration or subsequent construction.
- Available right-of-way.
- Areas of potential instability such as deep deposits of weak cohesive and organic soils, slide debris, high groundwater table, bedrock outcrops, etc.

Reconnaissance should be performed by a geotechnical engineer or by an engineering geologist. Before the start of field exploration, any data available from previous subsurface investigations and those that can be inferred from geologic maps of the area should be studied. Topographic maps and aerial photographs, if available, should be studied. Much useful information of this type is available from the U.S. Geological Survey, the Natural Resources Conservation Service, the U.S. Department of Agriculture, and local planning boards or county offices.

2.6.3 Subsurface Exploration

The subsurface exploration program generally consists of soil soundings, borings, and test pits. The type and extent of the exploration should be decided after review of the preliminary data obtained from the field reconnaissance, and in consultation with a geotechnical engineer or an engineering geologist. The exploration must be sufficient to evaluate the geologic and subsurface profile in the area of construction. For guidance on the extent and type of required investigation, the FHWA NHI-01-031 Subsurface Investigations – Geotechnical Site Characterization reference manual (Mayne et al., 2002), should be reviewed.

The following guidelines are recommended (Christopher et al., 1990) for the subsurface exploration for potential MSE applications:

- Borings: The type (soil boring and/or cone penetration), number, location, and depth of investigation points generally are dictated by the project stage (i.e., feasibility study, preliminary, or final design), availability of existing geotechnical data, variability of subsurface conditions, length of the structure, what the structure supports, and other project details. Soil borings should be performed along the front and the back of the proposed reinforced soil structure. The width of the MSE wall or slope structure may be assumed as 0.8 times the anticipated height. Borings at the following intervals should be considered:
 - 100 ft (30 m) along the alignment of the reinforced soil structure; and
 - 150 ft (45 m) along the back of the reinforced soil structure
- The boring depth should be controlled by the general subsurface conditions. Where bedrock is encountered within a reasonable depth, rock cores should be obtained for a length of about 10 ft (3 m). This coring will be useful to distinguish between solid rock and boulders. Deeper coring may be necessary to better characterize rock slopes behind new retaining structures. In areas of soil profile, the borings should extend at least to a depth equal to twice the height of the wall/slope. If subsoil conditions within this depth are found to be weak and unsuitable for the anticipated pressures from the structure height, then the borings must be extended until reasonably strong soils are encountered.
- In each boring, soil samples should be obtained at 5-foot (1.5 m) depth intervals and at changes in strata for visual identification, classification, and laboratory testing. Methods of sampling may follow AASHTO T 206 or AASHTO T 207 (*Standard Penetration Test* and *Thin-Walled Shelby Tube Sampling*, respectively), depending on the type of soil. In granular soils, the Standard Penetration Test can be used to obtain disturbed samples. In cohesive soils, undisturbed samples should be obtained by thin-walled sampling procedures. In each boring, careful observation should be made for the prevailing water table, which should be observed not only at the time of sampling but also at later times to obtain a good record of prevailing water table conditions. If necessary, piezometers should be installed in a few borings to observe long-term water levels.
- Both the Standard Penetration Test and the Cone Penetration Test, ASTM D3441, provide data on the strengths and density of soils. In some situations, it may be desirable to perform in-situ tests using a dilatometer, pressuremeter, or similar means to determine soil modulus values.

- Adequate bulk samples of available soils should be obtained and evaluated as indicated in the following testing section to determine the suitability of the soil for use as backfill in the MSE structures. Such materials should be obtained from all areas from which preliminary reconnaissance indicates that borrow materials will be used.
- Test-pit explorations should be performed in areas showing instability or to explore further availability of the borrow materials for backfill. The locations and number of test pits should be decided for each specific site, based on the preliminary reconnaissance.

2.6.4 Laboratory Testing

Soil samples should be visually examined and appropriate tests performed for classification according to the Unified Soil Classification System (ASTM D2488). These tests permit the engineer to decide what further field or laboratory tests will best describe the engineering behavior of the soil at a given project site. Index testing includes determination of moisture content, Atterberg limits, and gradation. The dry unit weight of representative undisturbed samples should also be determined.

Shear strength determination by unconfined compression tests, direct shear tests, or triaxial tests will be needed for external stability analyses of MSE walls and slopes. At sites where compressible cohesive soils are encountered below the foundations of the MSE structure, it is necessary to perform consolidation tests to obtain parameters for performing service state settlement analyses. Both undrained and drained (effective stress) parameters should be obtained for cohesive soils, to permit evaluation of both long-term and short-term conditions.

Of particular significance in the evaluation of any material for possible use as backfill are the grain size distribution and plasticity. The effective particle size (D_{10}) can be used to estimate the permeability of cohesionless materials. Laboratory permeability tests may also be performed on representative samples compacted to the specified density. Additional testing should include direct shear tests on a few similarly prepared samples to determine shear strength parameters under long and short-term conditions. The compaction behavior of potential backfill materials should be investigated by performing laboratory moisture-density relationship tests according to AASHTO T 99, or T 180.

Properties to indicate the potential aggressiveness of the backfill material and the in-situ soils behind the reinforced soil zone must be measured. Tests include:

- pH (AASHTO T 289; ASTM D4972)
- Electrical resistivity.

- Salt content including water soluble sulfate (AASHTO T 290), sulfides (ASTM D4327), and chlorides (ASTM D4327).

The test results will provide necessary information for planning degradation protection measures and will help in the selection of reinforcement elements with adequate durability. designers.

2.6.5 Foundation Soils

The development and implementation of an adequate subsurface investigation program for the existing foundation conditions is a key element for ensuring successful project implementation. Causes for distress experienced in projects are often traced to inadequate subsurface exploration programs that did not disclose local or significant areas of soft soils, causing significant local differential settlement and distress to the facing panels. In a few documented extreme cases, such foundation weakness caused complete foundation failures leading to catastrophic collapses.

Determination of engineering properties for foundation soils should be focused on establishment of bearing resistance, global stability, settlement potential, and position of groundwater levels. For bearing capacity determinations, frictional and cohesive parameters (ϕ , c) as well as unit weights (γ_T) and groundwater position are normally required in order to calculate bearing resistance in accordance with Article 10.6.3.1 for soil and 10.6.3.2 for rock in AASHTO (2007). The effects of load inclination and footing shape may be omitted for Strength Limit State.

For foundation settlement determinations, the results of conventional settlement analyses with Service Limit State load factors, and using laboratory time-settlement data, coefficients of consolidation C_c , in conjunction with approximate value for compression index C_v , obtained from correlations to soil index tests (moisture content, Atterberg limits) should be used. The results of settlement analyses, especially with respect to differential settlement should be used to determine the ability of the facing and connection system to tolerate such movements or the necessity for special details or procedures to accommodate the differential movement anticipated.

Major foundation weakness and compressibility may require the consideration of ground improvement techniques to achieve adequate bearing capacity, or limiting total or differential settlement. Techniques successfully used, include surcharging with or without prefabricated vertical drains, stone columns, dynamic compaction, compaction grouting and the use of lightweight fill to reduce settlement. Additional information on ground improvement

techniques can be found in the FHWA Ground Improvement Manuals, FHWA NHI-06-019 and FHWA NHI-06-020 (Elias et al., 2006). As an alternate for MSE walls, faces constructed of geosynthetic wraps, welded wire mesh or gabion baskets, which will tolerate significant differential settlement, could be constructed and permanent facings such as concrete panels attached after the settlement has occurred, see Section 3.6.6. Of particular concern, are situations where the MSEW structure may terminate adjacent to a rigidly supported structure such as a pile supported abutment at the end of a retained approach fill.

Evaluation of these foundation related issues are typically beyond the scope of services provided by wall/slope system suppliers. Evaluations of this type are the responsibility of agency engineers or consultant geotechnical and are required before selection of the appropriate MSE wall or RSS system.

2.7 PROJECT EVALUATION

2.7.1 Structure Selection Factors

The major factors that influence the selection of an MSE/RSS alternative for any project include:

- Geologic and topographic conditions
- Environmental conditions
- Size and nature of the structure
- Aesthetics
- Durability considerations
- Performance criteria
- Availability of materials
- Experience with a particular system or application
- Cost

Many MSEW systems have proprietary features. Some companies provide services including design assistance, preparation of plans and specifications for the structure, supply of the manufactured wall components, and construction assistance.

The various wall systems have different performance histories, and this sometimes creates difficulty in adequate technical evaluation. Some systems are more suitable for permanent walls, others are more suitable for low walls, and some are applicable for remote areas while others are more suited for urban areas. The selection of the most appropriate system will thus depend on the specific project requirements.

RSS embankments have been constructed with a variety of geosynthetic reinforcements and treatments of the slope face. These factors again may create an initial difficulty in adequate technical evaluation, but with the use of this manual easily addressed by department personnel to prepare generic designs. A number of geosynthetic reinforcement suppliers provide design services as well as technical assistance during construction.

Specific technical issues focused on selection factors are summarized in the following sections.

2.7.2 Geologic and Topographic Conditions

MSE structures are particularly well suited where a "fill-type" wall must be constructed or where side-hill fills are indicated. Under these latter conditions, the volume of excavation may be small, and the general economy of this type of construction is not jeopardized. Economic advantages diminish with large cut volumes to accommodate the reinforced soil structure, but in many instances remain viable.

The adequacy of the foundation to support the fill weight must be determined as a first-order feasibility evaluation.

Where soft compressible soils are encountered, preliminary stability analyses must be made to determine if sufficient shear strength is available to support the weight of the reinforced fill. As a rough first approximation for vertically faced MSE structures, the available shear strength must be equal to at least 2.0 to 2.5 times the weight of the fill structure. For RSS embankments the required foundation strength is somewhat less and dependent on the actual slope considered.

Where these conditions are not satisfied, ground improvement techniques (see FHWA NHI-06-019 and NHI-06-020, Elias et al., 2006) must be considered to increase the bearing capacity at the foundation level. These techniques include but are not limited to:

- Excavation and removal of soft soils and replacement with a compacted structural fill.
- Use of lightweight fill materials.
- In-situ densification by dynamic compaction or improvement by use of surcharging with or without prefabricated vertical drains.
- Construction of aggregate columns.

Where marginal to adequate foundation strength is available, preliminary settlement analyses should be made to determine the potential for differential settlement, both longitudinally along a proposed structure as well as transverse to the face. This second-order feasibility

evaluation is useful in determining the appropriate type of facing systems for MSE walls and in planning appropriate construction phasing to accommodate the settlement.

In general, concrete-faced MSE structures using discrete articulating panels can accommodate maximum longitudinal differential settlements of about 1/100, without the introduction of special sliding joints between panels. Full-height concrete panels are considerably less tolerant and generally should not be considered where differential settlements are anticipated. MBW unit faced walls can accommodate maximum longitudinal differential settlements of about 1/200, with the introduction of special slip joints.

The performance of reinforced soil slopes generally is not affected by differential longitudinal settlements.

2.7.3 Environmental Conditions

The primary environmental condition affecting reinforcement type selection and potential performance of MSE structures is the aggressiveness of the in-situ ground regime that can cause deterioration to the reinforcement. Post construction changes must be considered where deicing salts or fertilizers are subsequently used.

For steel reinforcements, in-situ regimes containing chloride and sulfate salts generally in excess of 200 PPM accelerate the corrosive process as do acidic regimes characterized by a pH of less than 5 (Elias, 1989). Alkaline regimes characterized by pH > 10 will cause accelerated loss of galvanization.

Certain in-situ regimes have been identified as being potentially aggressive for geosynthetic reinforcements. Polyester (PET) degrades in highly alkaline or acidic regimes. Polyolefins appear to degrade only under certain highly acidic conditions.

For additional specific discussions on the potential degradability of reinforcements, refer to the companion Corrosion/Degradation reference manual and are summarized in Section 3.5.

A secondary environmental issue is site accessibility, which may dictate the nature and size of the facing for MSE wall construction. Sites with poor accessibility or remote locations may lend themselves to lightweight facings such as geotextile or geogrid wrapped facings and vegetative covers; metal skins; welded wire mesh, gabions, modular blocks (MBW) which could be erected without heavy lifting equipment.

RSS construction with an organic vegetative cover must be carefully chosen to be consistent with native perennial cover that would establish itself quickly and would thrive with available site rainfall.

2.7.4 Size and Nature of Structure

Theoretically there is no upper limit to the height of MSE wall that can be constructed. Structures up to 135 ft (41 m) have been successfully constructed in the U.S. with steel reinforcements, although such heights for transportation-related structures are rare. RSS embankments have been constructed to up to a height of 242 ft (74 m) in the U.S. with geogrid reinforcements, but again such heights for transportation-related structures are rare.

Practical limits are often dictated by economy, available ROW, and the tensile strength of commercially available soil reinforcing materials. For bridge abutments there is no theoretical limit to the span length that can be supported, although the longer the span, the greater is the area of footing necessary to support the beams. Since the nominal bearing resistance of the reinforced fill for the service limit state is usually limited to 4000 psf (200 kPa), a large abutment footing further increases the span length, adding cost to the superstructure. This additional cost must be balanced by the potential savings of the MSE alternate to a conventional abutment wall, which would have a shorter span length. As an option in such cases, it might be economical to consider support of the bridge beams on deep foundations, placed within (or in front of) the reinforced fill zone.

The lower limit to height is usually dictated by economy. When used with traffic barriers, low walls on good foundations of less than 10 to 14 ft (3 to 4 m) are often uneconomical, as the cost of the overturning moment leg of the traffic barrier approaches one-third of the total cost of the MSE structure in place. For cantilever walls, the barrier is simply an extension of the stem with a smaller impact on overall cost.

The total size of structure (square feet of face) has little impact on economy compared with other retaining wall types. However, the unit cost for small projects of less than 3,000 ft² (300 m²) is likely to be 10 to 15 percent higher.

RSS may be cost effective in rural environments, where ROW restrictions exist or on widening projects where long sliver fills are necessary. In urban environments, they should be considered where ROW is available, as they are generally more economical than vertically faced MSE wall structures.

2.7.5 Aesthetics

Precast concrete facing panels may be cast with an unlimited variety of texture and color for an additional premium that seldom exceeds 15 percent of the facing cost, which on average would mean a 4 to 6 percent increase on total in-place cost.

Modular block wall facings are often comparable in cost to precast concrete panels except on small projects (less than 4,000 ft² {400 m²}) where the small size introduces savings in erection equipment cost and the need to cast special, made-to-order concrete panels to fit what is often irregular geometry. MBW facings may be manufactured in color and with a wide variety of surface finishes.

The outward face treatment of RSS, generally is by vegetation, which is initially more economical than the concrete facing used for MSE structures. However, maintenance costs may be considerably higher, and the long-term performance of many outward face treatments has not been established.

2.7.6 Questionable Applications

The current AASHTO LRFD Specifications (2007) states that MSE walls should not be used under the following conditions:

- When utilities other than highway drainage must be constructed within the reinforced zone where future access for repair would require the reinforcement layers to be cut. A similar limitation should be considered for RSS structures.
- With galvanized metallic reinforcements exposed to surface or ground water contaminated by acid mine drainage or other industrial pollutants as indicted by low pH and high chlorides and sulfates.
- When floodplain erosion may undermine the reinforced fill zone, or where the depth to scour cannot be reliably determined.

2.8 ESTABLISHMENT OF PROJECT CRITERIA

The engineer should consider each topic area presented in this section at a preliminary design stage and determine appropriate elements and performance criteria.

The process consists of the following successive steps:

- Consider all possible alternatives.
- Choose a system (MSEW or RSS).
- Consider facing options.
- Develop performance criteria (loads, design heights, embedment, settlement tolerances, foundation capacity, effect on adjoining structures, etc.).
- Consider effect of site on corrosion/degradation of reinforcements.

2.8.1 Alternates

Cantilever, gravity, semi gravity, or counterforted concrete walls or soil embankments are the usual alternatives to MSE walls and abutments and RSS.

In cut situations, in-situ walls such as tieback anchored walls, soil nailed walls or nongravity cantilevered walls are often more economical, although where limited ROW is available, a combination of a temporary in-situ wall at the back end of the reinforcement and a permanent MSE wall is often competitive.

For waterfront or marine wall applications, sheetpile walls with or without anchorages or prefabricated concrete bin walls that can be constructed in the wet are often, if not always, both more economical and more practical to construct.

2.8.2 Facing Considerations

The development of project-specific aesthetic criteria is principally focused on the type, size, and texture of the facing, which is the only visible feature of any MSE structure.

For permanent applications, considerations should be given to MSE walls with precast concrete panels. They are constructed with a (near) vertical face. Currently, the size of panels commercially produced varies from 20 to 50 ft² (1.8 to 4.5 m²). Generally, full height panels may be considered for walls up to about 14 to 16 ft (4 to 5 m) in height on foundations that are not expected to settle. Experienced contractors have successfully constructed taller full height panels (e.g., 25 ft {7.5 m}) on competent foundations. The precast concrete panels can be manufactured with a variety of surface textures and geometries, as shown in Figure 2-6.

For permanent applications, considerations should be given to MBW facings, which are available in a variety of shapes and textures as shown in Figure 2-7. They range in facial area from 0.5 to 1 ft² (0.05 to 0.1 m²). An integral feature of this type of facing is a front

batter ranging from nominal up to 15 degrees. Project geometric constraints, i.e., the bottom of wall and top of wall horizontal limits, may limit the amount of permissible batter and, thus, the types of MBW units that may be used. Note that the toe of these walls step back as the foundation elevation steps up, due to the stacking arrangement and automatic batter.

Other facing options are gabion, timber faced, or vegetated.

For temporary walls, significant economy can be achieved with geosynthetic wrapped facings. They may be made permanent by applying gunite or cast-in-place concrete in a post-construction application.

For RSS structures, the choice of slope facing may be controlled by climatic and regional factors. For structures of less than 33 ft (10 m) height with slopes of approximately 1 Horizontal:1 Vertical (1H:1V) or flatter, a vegetative "green slope" can be usually constructed using an erosion control mat or mesh and local grasses. Where vegetation cannot be successfully established and/or significant run-off may occur, armored slopes using natural or manufactured materials may be the only choice to reduce future maintenance. For additional guidance see Section 8.5.

2.8.3 Performance Criteria

Performance criteria for MSE structures with respect to design requirements are governed by design practice or codes such as contained in Article 11.10 of 2007 AASHTO LRFD Specifications for Highway Bridges. These requirements consider load and resistance factors with respect to various failure modes and materials, and for various limit states. No specific AASHTO guidance is presently available for RSS structures.

With respect to lateral wall displacements, no method is presently available to definitively predict lateral displacements, most of which occur during construction. The horizontal movements depend on compaction effects, reinforcement extensibility, reinforcement length, reinforcement-to-panel connection details, and details of the facing system. A rough estimate of probable lateral displacements of simple structures that may occur during construction can be made based on the reinforcement length to wall-height ratio and reinforcement extensibility as shown in Figure 2-15, for the serviceability limit check.

This figure indicates that increasing the length-to-height ratio of reinforcements from its theoretical lower limit of 0.5H to 0.7H, decreases the deformation by 50 percent.

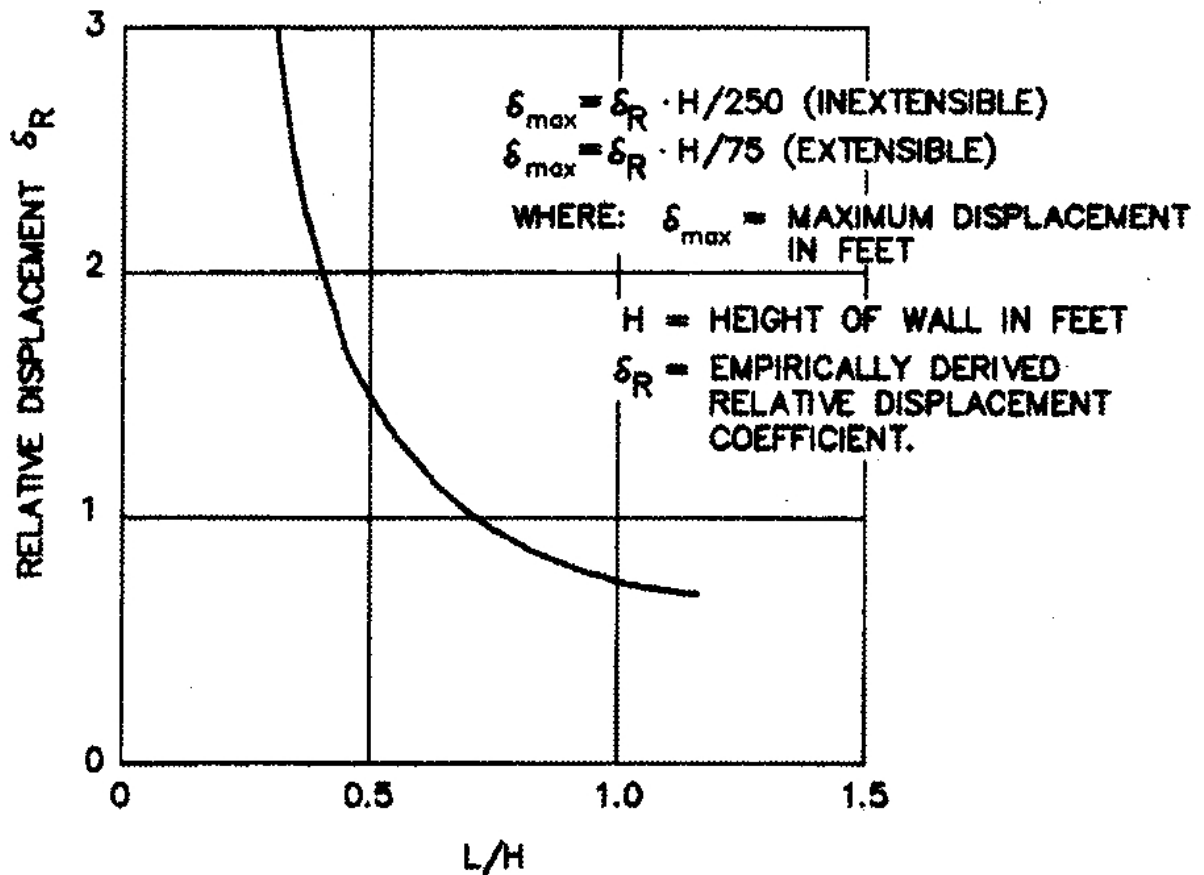

For $L = 0.7 H$

Metallic (inextensible) reinforcement $\approx 3/4$ -in. per 10 ft of wall height

Geogrid (moderately extensible) reinforcement ≈ 1 in. per 10 ft of wall height

Geotextile (extensible) reinforcement ≈ 1.5 in. per 10 ft of wall height

Based on 20 ft high walls, relative displacement increases approximately 25% for every 400 psf surcharge. Experience indicates that for higher walls, the surcharge effect may be greater.

NOTE: This figure is only a guide. Actual displacement will depend, in addition to the parameters addressed in the figure, on soil characteristics, compaction effort, and contractor

Figure 2-15. Empirical curve for estimating lateral displacement during construction for MSE walls (after FHWA RD 89-043 {Christopher et al., 1990}).

Performance criteria are both site and structure-dependent. Structure-dependent criteria consist of safety factors or a consistent set of load and resistance factors as well as tolerable movement criteria of the specific MSE structure selected.

Recommended MSE Wall load and resistance factors with respect to the various potential failure modes and limit states are presented in Chapter 4.

A number of site-specific project criteria need to be established at the inception of design:

- **Design limits and wall height.** The length and height required to meet project geometric requirements must be established to determine the type of structure and external loading configurations.
- **Alignment limits.** The horizontal (perpendicular to wall face) limits of bottom and top of wall alignment must be established as alignments vary with batter of wall system. The alignment constraints may limit the type and maximum batter of the wall facing, particularly with MBW units.
- **Length of reinforcement.** A minimum reinforcement length of $0.7H$ is recommended for MSE walls. Longer lengths are required for structures subject to surcharge loads, or where foundation conditions affect lateral sliding and/or global/compound slope stability, as listed in Table 2-1. Shorter lengths can be used in special situations (see Chapter 6).
- **External loads.** The external loads may be soil surcharges required by the geometry, adjoining footing loads, loads as from traffic, and/or traffic impact loads. The magnitude of the minimum traffic loads outlined in Article 3.11.6.4 (AASHTO, 2007) is a uniform load equivalent to 2 ft (0.6 m) of soil over the traffic lanes. The traffic load is greater for some cases (see Tables 4-5 and 4-6).
- **Wall embedment.** The minimum embedment depth for walls from adjoining finished grade to the top of the leveling pad should be based on bearing, settlement, and slope stability considerations. Current practice based on local bearing considerations, recommends the minimum embedment depths listed in Table 2-1.

Table 2-1. Typical Minimum Length of Reinforcement.

Case	Typical Minimum L/H Ratio
Static loading with or with traffic surcharge	0.7
Sloping backfill surcharge	0.8
Seismic loading	0.8 to 1.1

Table 2-2. Minimum MSEW Embedment Depths.

Slope in Front of Wall	Minimum Embedment Depth to Top of Leveling Pad*
All Geometries	2 ft minimum
horizontal (walls)	H/20
horizontal (abutments)	H/10
3H:1V	H/10
2H:1V	H/7
1.5H:1V	H/5
* Minimum depth is the greater of applicable values listed, frost depth, or scour depth.	

Larger values may be required, depending on shrinkage and swelling of foundation soils, seismic activity, and/or scour. A greater embedment depth may also be required based upon bearing, settlement, and/or global stability calculations. As noted, the minimum in any case is 2 ft (0.6 m), except for structures founded on rock at the surface, where no embedment may be used. Alternately, frost-susceptible soils could be overexcavated and replaced with non-frost susceptible fill, hence reducing the embedment depth (and overall wall height).

A minimum horizontal bench 4-ft (1.2 m) wide as measured from the face shall be provided in front of walls founded on slopes. The bench may be formed or the slope continued above that level (11.10.2.2, AASHTO {2007}), as illustrated in Figure 2-16. The horizontal bench is intended to provide resistance against general bearing failure and to provide access for maintenance inspections (C11.10.2.2, AASHTO {2007}).

For walls constructed along rivers and streams where the depth of scour has been reliably determined, a minimum embedment of 2 ft (0.6 m) below scour depth is recommended.

Embedment is not required for RSS unless dictated by stability requirements.

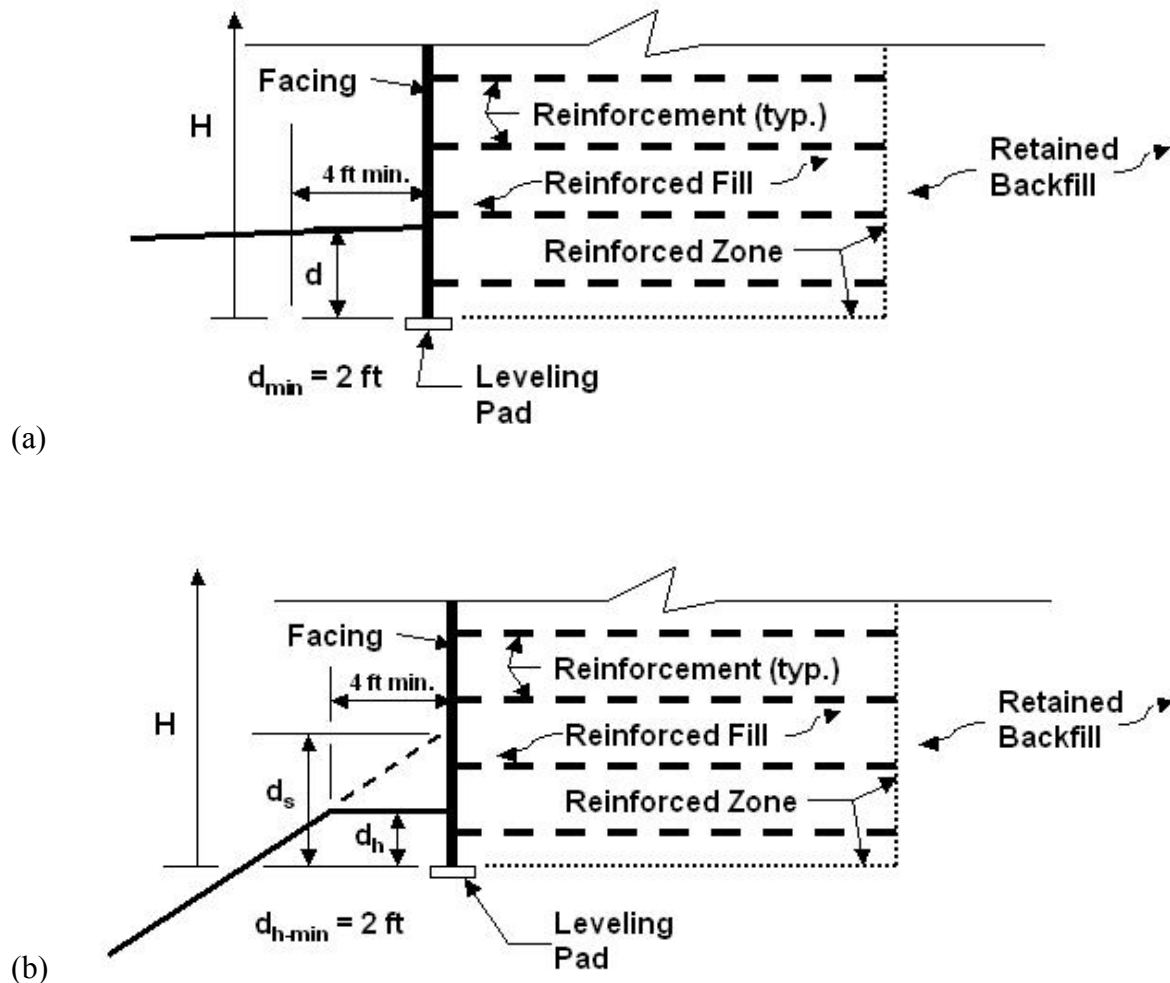

Figure 2-16. MSE wall embedment depth requirements, (a) level toe condition and (b) benched slope toe condition (d_h = minimum depth for horizontal slope and d_s = minimum depth for sloping toe, from Table 2-2).

- **Seismic Activity.** Due to their flexibility, MSE wall and slope structures are quite resistant to dynamic forces developed during a seismic event, as confirmed by the excellent performance in several recent earthquakes.

Seismic loading analysis of MSE walls is an Extreme Event limit state. Pseudo-static analysis procedures for seismic stability are presented in Chapter 7. Note that for sites

where the anticipated ground acceleration is greater than 0.29 g, significant total lateral structure movements may occur, and a deformation analysis for the structure is recommended (C11.10.7.1, AASHTO {2007}).

MSE walls should be designed/checked for seismic stability on all sites where the A_s coefficient is greater than 0.05. For RSS structures, seismic analyses should be included regardless of acceleration magnitude.

- **Tolerance of precast facing panels to settlement.** MSE structures have significant deformation tolerance both longitudinally along a wall and perpendicular to the front face. Therefore, poor foundation conditions seldom preclude their use. However, where significant differential settlements are anticipated (greater than 1/100) sufficient joint width and/or slip joints must be provided to preclude panel cracking. This factor may influence the type and design of the facing panel selected.

Square panels generally adapt to larger longitudinal differential settlements better than long rectangular panels of the same surface area. A joint width of $\frac{3}{4}$ -inch (20 mm) is generally recommended. Guidance on differential settlements that can be tolerated is presented in Table 2-3, for panels with a surface of 30 ft² (2.8 m²) or less and for panels with surface area greater than 30 ft² (2.8 m²) and less than or equal to 75 ft² (7 m²).

Bearing pads used between segmental precast concrete panels should be designed to accommodate downdrag forces on it due to elastic settlement of the wall fill. Bearing pad design and specification are addressed in Section 3.6.1.a and Section 10.5, respectively.

MSE walls constructed with full height panels should be limited to differential settlements of 1/500. Walls with drycast facing (MBW) should be limited to settlements of 1/200. For walls with welded wire facings, the limiting differential settlement should be 1/50.

Where significant differential settlement perpendicular to the wall face is anticipated, the reinforcement connection may be overstressed. Where the back of the reinforced soil zone will settle more than the face, the reinforcement could be placed on a sloping fill surface which is higher at the back end of the reinforcement to compensate for the greater vertical settlement. This may be the case where a steep surcharge slope is constructed. This latter construction technique, however, requires that surface drainage be carefully controlled after each day's construction. Alternatively, where significant differential settlements are anticipated, ground improvement techniques may be warranted to limit the settlements.

Table 2-3. Relationship Between Joint Width and Limiting Differential Settlements for MSE Precast Panels (after C11.10.4.1 AASHTO {2007}).

Joint Width	Limiting Differential Settlement	
	Area \leq 30 ft ²	30 ft ² < Area \leq 75 ft ²
³ / ₄ -in. (20 mm)	1/100	1/200

2.8.4 Design Life

MSE walls should be designed for a service life based on consideration of the potential long-term effects of material deterioration, seepage, stray currents and other potentially deleterious environmental factors on each of the material components comprising the wall. For most applications, permanent retaining walls should be designed for a minimum service life of 75 years. Retaining walls for temporary applications are typically designed for a service life of 36 months or less.

A greater level of safety and/or longer service life (i.e., 100 years) may be appropriate for walls that support true bridge abutments, buildings, critical utilities, or other facilities for which the consequences of poor performance or failure would be severe.

The quality of in-service performance is an important consideration in the design of permanent retaining walls. Permanent walls shall be designed to retain an aesthetically pleasing appearance, and not require significant maintenance throughout their design service life.

For RSS structures, similar minimum design life ranges should be adopted.

2.9 PROPRIETARY ASPECTS

The distinguishing characteristics of MSE trademarked systems from generic systems are patented features or materials of construction.

At present the following significant components are known to be covered by unexpired patents:

- Connection details between grid reinforcement and precast panel covered by a number of patents issued to various suppliers. In general, these patents cover a specific design for the concrete-embedded portion of connecting member only.
- Most MBW facing units are covered by recent design patents.

A number of patents may be in force for specific MSE construction methods under water, specific types of traffic barriers constructed over MSE walls, and facing attachments to temporary facings.

2.10 CASE HISTORIES – MSE WALLS

2.10.1 Mn/DOT Crosstown Project MSE Walls

MSE walls were used extensively on the Crosstown Project, located in Minneapolis, Minnesota. The walls are used to widen existing roadways, construct new ramps, and construct new bridge approaches. The project enlarges and streamlines the I35W and Mn Hwy 62 interchange. This is a heavily traveled roadway in a congested urban area. Several bridges were widened and several new bridges were constructed as part of this project. The detailed wall designs and the wall components were supplied by a Minnesota Department of Transportation (Mn/DOT) pre-approved MSE wall vendor. Design followed the ASD method (AASHTO 17th Edition, 2002). Most of the walls were constructed during the 2008 and 2009 construction seasons.

Approximately 300,000 ft² (28,000 m²) of MSE walls were constructed in 24 separate walls. Typical wall heights are approximately 25 to 30 ft (7.5 to 9 m), and the maximum wall height is 45 ft (14 m). The MSE walls are faced with architectural segmental precast panels and reinforced with steel bar mats. Facing panels are painted after wall construction. The architectural relief included false columns, on the long and tall walls, as shown in Figure 2-17. The reinforced wall fill is an angular, well-graded sand. The walls are designed for a 100-year life. Many walls have traffic barriers on top of the reinforced zoned. The barriers were designed by the Mn/DOT project design consultant. A geomembrane was specified and installed across the top of the reinforced zones to prevent, or minimize, infiltration of de-icing salt runoff into the reinforced fill.

Temporary welded wire mesh (WWM) faced walls were also used on this project for temporary bridge abutments (see Figure 2-2), bridge approach embankments, and

construction staging. These walls were also designed and supplied by the same Mn/DOT pre-approved vendor.

The use of MSE walls on this project provided a relatively rapid means of wall construction, and produced structures designed for a 100-year life. Cast-in-place, concrete cantilever walls were also extensively used on this project. Approximately 500,000 ft² (49,000 m²) of C.I.P. walls were constructed.

The cost of these MSE walls was \$30.50 per ft² (\$330 per m²) of face area, plus \$17.00 per yd³ (\$20 per m³) for the reinforced wall fill and \$375.00 per yd³ (\$450 per m³) of concrete for the traffic barrier moment slab. MSE wall cost with the select granular wall fill and moment slab was approximately \$54.50 per ft² (\$585 per m²) of face area. The MSE wall costs do not include the traffic barrier and noise wall. The cost of the cast-in-place walls on the project was \$67.20 per ft² (\$723 per m²) of face area plus cost of backfill, for an approximate total cost of \$76 per ft² (\$820 per m²) of face area.



Figure 2-17. MSE wall construction on Mn/DOT Crosstown Project, 2008.

2.10.2 Veterans Memorial Overpass True Abutment MSE Walls

The Pima County Department of Transportation's Veterans Memorial Overpass (VMO) project is located in Tucson, Arizona. The project included a 5-span, 348-ft long bridge (shown in Figure 2-18) that takes Palo Verde Road over Aviation Parkway, Union Pacific railroad assembly area tracks, and 36th Street. The North and South abutments consist of spread footings on top of 25-ft and 35-ft high MSE walls, respectively. MSE walls were proposed as part of value engineering proposal to replace cast-in-place walls. The walls were designed using the ASD method (AASHTO 17th Edition, 2002). The walls were constructed in 2004 and 2005.

An abutment is shown in Figure 2-19, and abutment cross section is illustrated in Figure 2-20. Both abutments are 150 ft long. The bridge consists of simply supported AASHTO Type III girders on elastomeric bearing pads resting on an abutment footing. The bridge footing at each abutment is 10.75 ft wide and 10.2 ft high. Clearance between the back of the coping and the toe of the footing is 6 in. The length of reinforcements was equal to the height of the abutment. Reinforced fill was a select granular fill, in accordance with AASHTO/FHWA requirements. Ribbed steel reinforcing strips were used for soil reinforcements, with 5-ft tall x 10-ft wide precast concrete segmental panels.

The upper 9 ft of foundation soils were over-excavated and replaced with engineered fill because they were loose and potentially collapsible. Underlying soils were dense to very dense clayey sands with refusal N-values. Groundwater depth is greater than 150 ft.

This project was monitored with over 500 survey points. Settlements of less than 1 in., primarily occurring during construction, were measured. No noticeable post-construction settlement has been observed.



Figure 2-18. Veterans Memorial Overpass. Figure 2-19. MSE true bridge abutment.

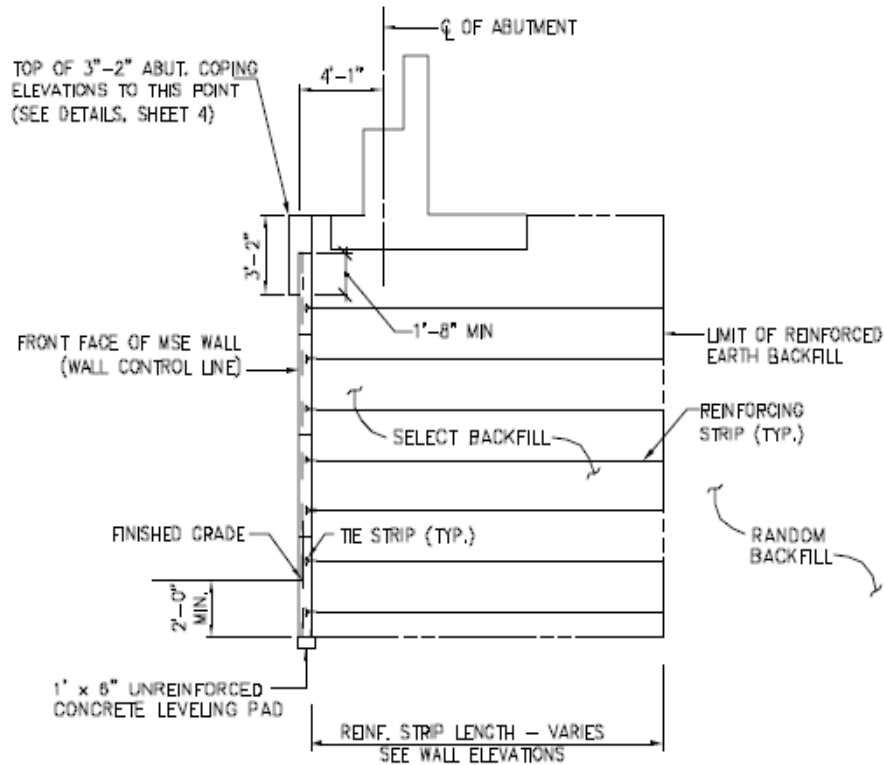

TYPICAL SECTION AT ABUTMENT

SCALE: N.T.S.

Figure 2-20. Typical cross section, VMO project.

2.10.3 SeaTac Airport Runway Extension MSE Wall

The tallest MSE wall in the U.S. to date has an exposed height of 138 ft (42 m) at its tallest section and was constructed to limit encroachment on adjacent creeks and wetlands and increase the land use area for the Third Runway project at SeaTac Airport (Figure 2-21). The West MSE wall was one of several walls constructed for the runway extension and is approximately 1430 ft (436 m) long, has four tiers formed by 8 ft (2.4 m) setbacks, and had a constructed height of 150 ft (148 m). The wall supports 20 ft (6.1 m) high, unreinforced 2H:1V slope. The MSE wall used steel reinforcing strips with concrete facing panels. In the lower tier, up to 25, 2 in. (50 mm) wide by 0.24 in. (6 mm) thick strips with a length of 116 ft (35.4 m) were connected to the 5 by 5-ft (1.5 by 1.5-m) panels. A full discussion of project background, design aspects, and instrumentation of these MSE walls are provided by Sankey et al. (2007) and Stuedlein et al. (2007).



Figure 2-21. SeaTac Airport runway extension MSE wall.

2.10.4 Guanella Pass Roadway Reconstruction

The Guanella Pass project is located in the Front Range of the Colorado Rocky Mountains within the Pike and Arapaho National Forests approximately 50 miles west of Denver. The overall goal of the Guanella Pass Road improvement project is to balance transportation requirements and roadway maintenance within a sensitive human and natural environment. The 24-mile long route connects two principal east-west corridors, US 285 and Interstate Highway 70. The original roadway supported two-way traffic with various widths and many sharp switchbacks in very steep mountainous terrain.

Twenty-one wired-faced MSE walls, extending a total length of almost 12,000 feet, were constructed along the project to gain adequate roadway width (typical wall is shown in Figure 2-22). Alternately, very long and steep down-slope embankments could have been constructed, but would have significantly impacted the forest. The MSE walls were able to

limit the width of disturbance to a little more than the roadway width. Some of the walls, which were visible from the road, were faced with an architectural concrete cast-in-place facing (as shown in Figure 2-23). The facing form liner was specifically designed by the Forest Service to simulate a more natural rockery type of wall, which was used extensively on the cut side of the road.

Due to the site geometry, these walls were constructed on very steep slopes ranging from 1.3H:1V to 1.5H:1V. MSE retaining walls for this project were evaluated for global stability using limit equilibrium methods using a minimum factor of safety for global stability of 1.3. In order to achieve this factor of safety under these geometric and loading conditions, the designers needed to work with each site individually. The reinforcement lengths were longer than typically used on MSE walls; they ranged from 70% to 120% of the wall height. In addition, the designers were able to vary the wall embedment below finished grade. These two parameters were used to provide a stable structure to support the new roadway.

In addition, the project was able to utilize the on-site soils for the reinforced backfill. The reinforced backfill met most of the AASHTO and FHWA requirements with the exception of the No. 200 sieve. In order to be able to use most of the soils excavated during construction, the project specifications allowed the use of up to 20% passing the No. 200 sieve instead of 15%. This was a significant savings to the project since it would have been difficult to waste the excavated material within the construction limits and it would have been very costly to import material for the walls, since the project was so remote.

MSE walls were selected for this project primarily due to their ease of construction and flexibility in difficult terrain and remote sites.



Figure 2-22. Guanella Pass wire-faced wall.



Figure 2-23. Guanella Pass architectural concrete faced wall.

CHAPTER 3

SOIL REINFORCEMENT PRINCIPLES AND SYSTEM DESIGN PROPERTIES

This chapter outlines the fundamental soil reinforcement principles that governs structure behavior, and develops system design parameters which are used for specific MSE wall and RSS design, detailed in Chapters 4, 6, 7, and 9.

The objectives of this chapter are to develop:

- An understanding of soil-reinforcement interaction.
- Introduce normalized pullout capacity concepts.
- Develop design soil parameters for select reinforced fill, retained backfill and foundation bearing capacity.
- Establish structural design properties.

3.1 OVERVIEW

As discussed in Chapter 2, mechanically stabilized earth systems (MSEW and RSS) have three major components: reinforcing elements, facing system, and reinforced fill. Reinforcing elements may be classified by stress/strain behavior and geometry. In terms of stress/strain behavior, reinforcing elements may be considered inextensible (metallic) or extensible (polymeric). This division is not strictly correct because some newer glass-fiber reinforced composites and ultra-high-modulus polymers have moduli that approach that of mild steel. Likewise, certain metallic woven wire mesh reinforcements, such as hexagon gabion material, have a structure that will deform more than the soil at failure and are thus considered extensible. Based on their geometric shapes, reinforcements can be categorized as strips, grids or sheets. Facing elements, when employed, can be precast concrete panels or modular blocks, gabions, welded wire mesh, cast-in-place concrete, timber, shotcrete, vegetation, or geosynthetic material. Reinforced fill refers to the soil material placed within the zone of reinforcement. The retained soil refers to the material, placed or in-situ, directly adjacent to the reinforced fill zone. The retained soil is the source of earth pressures that the reinforced zone must resist. A drainage system below and behind the reinforced fill is also an important component, especially when using poorly draining backfill.

3.2 ESTABLISHMENT OF REINFORCED AND RETAINED FILL ENGINEERING PROPERTIES

3.2.1 Reinforced Fill Soil

The selection criteria of reinforced fill should consider long-term performance of the completed structure, construction phase stability and the degradation environment created for the reinforcements. Much of engineering communities' knowledge and experience with MSE wall structures to date has been with select, cohesionless backfill. Hence, knowledge about internal stress distribution, pullout resistance, and failure surface shape is constrained and influenced by the unique engineering properties of these soil types. Granular soils are ideally suited to MSE wall and RSS structures. Many agencies have adopted conservative reinforced fill requirements for both walls and slopes. These conservative properties are suitable for inclusion in standard specifications or special provisions when project specific testing is not feasible and when the quality of construction control and inspection may be in question. **It should be recognized, however, that using conservative reinforced fill property criteria cannot completely replace a reasonable degree of construction control and inspection.**

In general, these select reinforced fill materials will be more expensive than lower quality materials. The specification criteria for each application (walls and slopes) differ somewhat primarily based on performance requirements of the completed structure (allowable deformations) and the design approach. Material suppliers of proprietary MSE systems each have their own criteria for reinforced fills. Detailed project reinforced fill specifications, which uniformly apply to all MSE wall and RSS systems, should be provided by the contracting agency. The following requirements are consistent with current practice:

Select Granular Fill Material for the Reinforced Zone of Walls. All fill material used in the structure volume for MSE wall structures should be reasonably free from organic or other deleterious materials and should conform to the gradation limits, PI and soundness criteria listed in Table 3-1. Note that Table 3-1 presents a broad gradation range that is applicable across the United States. Individual DOTs may adjust this range based upon locally available and economical select granular fill. The reinforced fill should be well-graded in accordance with the Unified Soil Classification System (USCS) in ASTM D2487. Unstable broadly graded soils (i.e., $C_u > 20$ with concave upward grain size distributions) and gap-graded soils should be avoided (see Kenney and Lau, 1985, 1986 for a method to identify unstable soils). These soils tend to pipe and erode internally, creating problems with both loss of materials and clogging of drainage systems.

Table 3-1. MSE Wall Select Granular Reinforced Fill Requirements.

<u>Gradation:</u> (AASHTO T-27)	<u>U.S. Sieve Size</u>	<u>Percent Passing</u> ^(a)
	4 in. (102 mm) ^(a,b)	100
	No. 40 (0.425 mm)	0-60
	No. 200 (0.075 mm)	0-15
<u>Plasticity Index, PI</u> (AASHTO T-90)	$PI \leq 6$	
<u>Soundness:</u> (AASHTO T-104)	The materials shall be substantially free of shale or other soft, poor durability particles. The material shall have a magnesium sulfate soundness loss of less than 30 percent after four cycles (or a sodium sulfate value less than 15 percent after five cycles).	
Notes: (a) To apply default F* values, C_u , should be greater than or equal to 4. (b) As a result of recent research on construction survivability of geosynthetics and epoxy coated reinforcements, it is recommended that the maximum particle size for these materials be reduced to ¾-in. (19 mm) for geosynthetics, and epoxy and PVC coated steel reinforcements unless construction damage assessment tests are or have been performed on the reinforcement combination with the specific or similarly graded large size granular fill. Prequalification tests on reinforcements using standard agency fill materials should be considered.		

The fill material must be free of organic matter and other deleterious substances, as these materials generally result in poor performance of the structure and enhance degradation for reinforcements. Other materials *such as soils containing mica, gypsum, smectite, montomorrilonite or other soft durability* particles should be carefully evaluated as large strains are typically required to reach peak strength and pullout capacity, resulting in larger lateral and vertical deformation than with higher quality granular fills. Use of salvaged materials such as asphaltic concrete millings or Portland Cement Concrete rubble is not recommended. Recycled asphalt is prone to creep resulting in both wall deformation and reinforcement pullout. Recycled concrete has a potential to produce tufa precipitate from unhydrated cement, which can clog drains and exude a white pasty substance onto the wall face creating aesthetic problems. The recycled concrete typically does not meet electrochemical properties and its corrosion potential has also not been fully evaluated, especially if residual wire and rebar are present that could create problems with dissimilar metals.

The compaction specifications should include a specified lift thickness and allowable range of moisture content with reference to optimum. Compaction moisture control should be $\pm 2\%$ of optimum moisture, w_{opt} .

The compaction requirements of reinforced fill are different in close proximity to the wall facing (within 3 ft {1 m}). Lighter compaction equipment (e.g., walk-behind vibratory plate or roller) and thinner lifts are used near the wall face to prevent buildup of high lateral pressures from the compaction and to prevent facing panel movement. **Because of the use of this lighter equipment, a reinforced fill material of good quality in terms of both friction and drainage, such as crushed stone may be used close to the face of the wall to provide adequate strength and minimize settlement in this zone.** If an open graded fill is used adjacent to the face, filtration requirements with the reinforced wall fill must be addressed, see Section 5.3.3. It should be noted that granular fill containing even a few percent fines (which can even develop or increase due to breakdown during compaction) may not be free draining and drainage requirements should always be carefully evaluated.

Marginal Reinforced Fill for MSE walls. MSE wall reinforced fill materials outside of these gradation and plasticity index requirements (Table 3-1) have been used successfully; however, problems including significant distortion and structural failure have been observed with finer grained and/or more plastic soils. A recent NCHRP research study (NCHRP 24-22) on Selecting Reinforced Fill Materials for MSE Retaining Walls has confirmed that that reinforced fill with up to 35% passing a No. 200 (0.75 mm) sieve could be safely allowed in the reinforced fill, provided the properties of the materials are well defined and controls are established to address the design issues. Design issues include drainage, corrosion, deformations, reinforcement pullout, constructability, and performance expectations. While there may be a significant savings in using lower quality reinforced fill, the affect on performance must be carefully evaluated.

For MSE walls constructed with reinforced fill containing more than 15% passing a No. 200 (0.075 mm) sieve and/or a PI exceeding 6, both total and effective shear strength parameters should be evaluated in order to obtain an accurate assessment of horizontal stresses, sliding, compound failure (behind and through the reinforced zone) and the influence of drainage on the analysis. Both long-term and short-term reinforcement pullout tests as well as soil/reinforcement interface friction tests should be performed. Settlement characteristics must be carefully evaluated, especially in relation to downdrag stresses imposed on connections at the face and settlement of supported structures. Drainage requirements at the back, face, and beneath the reinforced zone must be carefully evaluated (e.g., use flow nets to evaluate influence of seepage forces and hydrostatic pressure). If marginal fill is used the surface of the wall should be positively sloped such that water drains away from the wall (which is a good practice for all MSE walls as discussed in Chapter 5, but most important if marginal fills are used). In addition, a geomembrane is recommended above the wall to preclude infiltration of seepage water into the fill (see Chapter 5, Section 5.3 for drainage design details). Again, these drainage features are good practice for all MSE walls. The

length of the upper 2 layers of reinforcement should be extended at least 3 to 5 ft beyond the lower reinforcement layers to reduce the potential for tension cracks to develop directly behind the reinforced zone. If the soil reinforcement is steel, the extended layers must be contained within select granular fill to avoid differential corrosion conditions.

Electrochemical tests should be performed on the reinforced fill to obtain data for evaluating degradation of reinforcements and facing connections (see Section 3.2.3). Moisture and density control during construction must be carefully controlled in order to obtain strength and interaction values. Deformation during construction also must be carefully monitored and maintained within defined design limits. Performance monitoring is also recommended for reinforced fill soils that fall outside of the requirements listed above, as detailed in Chapter 11.

Reinforced Rock Fill for Wall or RSS Structures. Material that is composed primarily of rock fragments (material having less than 25 percent passing a $\frac{3}{4}$ in (20 mm) sieve) should be considered to be a rock backfill. The maximum particle size should not exceed the limits listed in Table 3-1. Such material should meet all the other non-gradation requirements such as soundness and electrochemical properties in Tables 3-1 to 3-4. When such material is used, a very high survivability geotextile filter (e.g., Type 1 geotextile in accordance with AASHTO M 288), designed for filtration performance following the guidelines in FHWA NHI-07-092 (Holtz et al., 2008), should encapsulate the rock backfill to within 3 ft (1 m) below the wall coping. Adjoining sections of separation fabric should be overlapped by a minimum of 12 in. (0.30 m). Additionally, the upper 3 ft (1 m) of fill should contain no stones greater than 3 in. (75 mm) in their greatest dimension, and should be composed of material not considered to be rock backfill, as defined herein. Where density testing is not possible, trial fill sections should be constructed with agency supervisory personnel and geotechnical specialist present to determine appropriate watering, in situ modification requirements (e.g., grading), lift thickness, and number of passes to achieve adequate compaction. Compaction can be determined by measuring the settlement of the trial section at a number of points after each pass (e.g., a minimum of 5 points measured at the center of a 1 ft square plate is typically required). Several lifts should be constructed to determine the appropriate number of passes, which will maximize compaction without excessively crushing the rock at the surface. The number of passes to achieve at least 80 percent of the maximum settlement should be required.

Select Reinforced Fill for RSS Structures. Less select reinforced fill can be used for RSS since facings are typically flexible and can tolerate some distortion during construction. Even so, a high quality embankment fill meeting the following gradation requirements to facilitate compaction and minimize reinforcement requirements is recommended. The

guidelines listed in Table 3-2 are provided as recommended reinforced fill requirements for RSS construction.

RSS reinforced fill compaction should be based on 95% of AASHTO T-99, and $\pm 2\%$ of optimum moisture, w_{opt} .

RSS fill materials outside of these gradation and plasticity index requirements have been used successfully as well as unsuccessfully. For fill materials outside of these limits, default values for strength and pullout are no longer applicable and laboratory tests must be performed. Issues with drainage problems, excessive distortion and settlement (as discussed above for marginal fill in MSE walls) must be carefully evaluated with finer grained and/or more plastic soils. Performance monitoring is also recommended for reinforced fill soils that fall outside of the requirements listed above, as detailed in Chapter 11.

Table 3-2. RSS Granular Reinforced Fill Requirements.

<u>Gradation:</u> (AASHTO T-27)	<u>U.S. Sieve Size</u>	<u>Percent Passing</u>
	4 in. (102 mm) ^(a,b) 3/4-inch (20 mm) ^(a)	100
	No. 4 (4.76 mm)	100 – 20
	No. 40 (0.425 mm)	0-60
	No. 200 (0.075 mm)	0 – 50
<u>Plasticity Index, PI</u> (AASHTO T-90)	$PI \leq 20$	
<u>Soundness:</u> (AASHTO T-104)	Magnesium sulfate soundness loss less than 30% after 4 cycles, based on AASHTO T-104 or equivalent sodium sulfate soundness of less than 15 percent after 5 cycles.	
Note:		
(a) To apply default F^* values, C_u , should be greater than or equal to 4.		
(b) As a result of recent research on construction survivability of geosynthetics and epoxy coated reinforcements, it is recommended that the maximum particle size for these materials be reduced to 3/4-in. (19 mm) for geosynthetics, and epoxy and PVC coated steel reinforcements unless construction damage assessment tests are or have been performed on the reinforcement combination with the specific or similarly graded large size granular fill. Prequalification tests on reinforcements using standard agency fill materials should be considered.		

Design Strength of Select Granular Reinforced Fill. The MSE wall and RSS reinforced fill criteria outlined previously represent materials that have been successfully used throughout the United States and resulted in excellent performance of MSEW and RSS structures. Peak shear strength parameters are used in the wall and slope analyses. For MSE walls using well fill meeting the gradation requirements in Table 3-1, a maximum effective friction angle ϕ' of 34 degrees is usually assumed (in accordance with Article 11.10.6.2, AASHTO, 2007), unless project-specific fill is tested by triaxial (per AASHTO T-296) or direct shear (per AASHTO T-236), per Article 11.10.6.2 (AASHTO, 2007). However, some nearly uniform fine sands meeting the specifications limits may exhibit friction angles of 30 to 32 degrees. When contractor furnished sources are used, the specification may also require testing of the source material to verify that its friction angle meets specification requirements (e.g., 34 degrees). Higher values may be used if substantiated by laboratory direct shear or triaxial test results for the site specific material used or proposed. If the measured friction angle is greater than 40 degrees, the angle of friction used for design should not exceed 40 degrees (Article 11.10.6.2, AASHTO {2007}). In all cases, the cohesion of the reinforced fill is assumed to be zero.

For RSS structures, where a considerably greater percentage of fines (minus No. 200 sieve) is permitted, lower bound values of frictional strength equal to 28 to 30 degrees would be typical for the reinforced fill requirements listed. A significant economy could again be achieved if laboratory direct shear or triaxial test results on the proposed fill are performed, justifying a higher value. Likewise, soils outside the gradation range listed should be carefully evaluated and monitored.

Limits of Reinforced Fill. For MSE walls, except back-to-back walls, and RSS, many agencies extend the reinforced fill beyond the free end of the reinforcement. Some agencies extend the reinforced fill 1 ft (0.3 m) beyond the reinforcement length, and some others extend the fill in a wedge behind the reinforced zone, as illustrated in Figure 3-1. For back-to-back walls wherein the free ends of the reinforcement of the two walls are spaced apart less than or equal to one-half the design height of the taller wall, reinforced backfill should be used for the space between the free ends of the reinforcements as well.

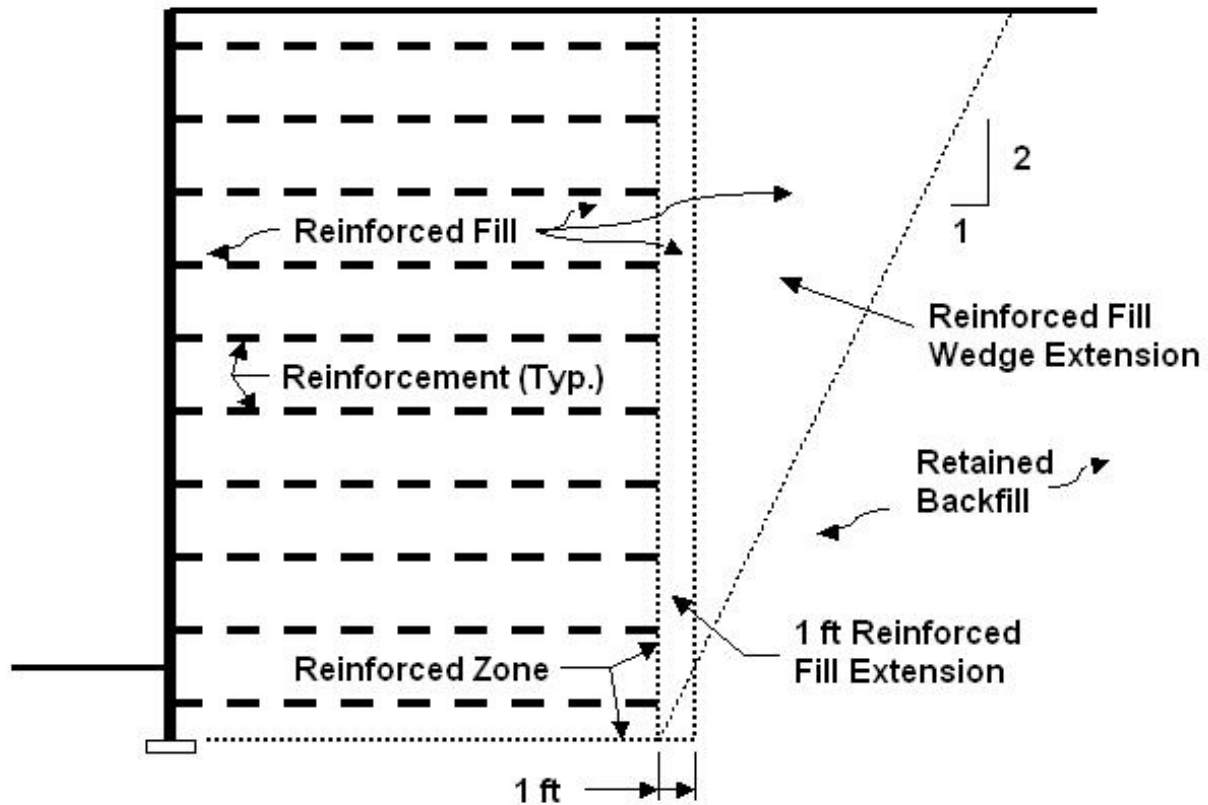

Figure 3-1. Examples of reinforced fill zone extension beyond the reinforced zone.

3.2.2 Retained Backfill and Natural Retained Soil

The key engineering properties required for the retained backfill are the strength and unit weight based on evaluation and testing of subsurface or borrow pit data. Friction angles (ϕ) may be determined from either by consolidated drained triaxial tests with pore pressure measurements or drained direct shear tests. As with reinforced fill, a cohesion value of zero is conservatively recommended for the long-term, effective strength of the retained fill. For backcut construction, if undisturbed samples cannot be obtained, friction angles may be obtained from in-situ tests or by correlations with index properties. The strength properties are required for the determination of the coefficients of earth pressure used in design as well as for overall stability analysis. In addition, the position of groundwater levels above the proposed base of construction must be determined in order to evaluate hydrostatic stresses in the retained fill and plan an appropriate drainage scheme to control ground water conditions. For most retained backfills lower bound frictional strength values of 28 to 30 degrees are reasonable for granular and low plasticity cohesive soils. For highly plastic retained fills and natural soils ($PI > 20$), even lower values would be indicated and should be evaluated for both drained and undrained conditions.

Backfill and natural soil behind the limits of the reinforced fill should be considered to be in the retained zone for a distance equal to 50 percent of the design height of the MSE wall. For the reasons discussed previously for reinforced fill, use of soils containing shale, mica, gypsum, smectite, montmorillonite or other soft particles of poor durability is discouraged and soundness limits should meet the criteria in Table 3-1.

The following are good practice to preclude potential problems with retained backfill soils. The percent fines, i.e., the fraction passing No. 200 sieve (0.075 mm), should be less than 50 and the Liquid Limit and Plasticity Index (PI) should be less than 40 and 20 percent, respectively, as determined in accordance with AASHTO T-90. The potential differential settlement/performance between the reinforced fill and retained backfill should be assessed. The agency should consider transition detailing between the reinforced zone and retained backfill by lengthening the upper two layers of soil reinforcement or extending the reinforced zone beyond the reinforcement length, as previously discussed. The maximum particle size in the retained backfill should be limited to the maximum particle size in the reinforced wall fill, at least within this transition zone. Material that is composed primarily of rock fragments (material having less than 25 percent passing a 3/4-inch sieve), should be considered to be a rock backfill (see Section 3.2.1).

3.2.3 Electrochemical Properties

The design of buried steel elements of MSE structures is predicated on reinforced fills exhibiting minimum or maximum electrochemical index properties and then designing the structure for maximum corrosion rates associated with these properties. These recommended index properties and their corresponding limits are shown in Table 3-3. **Reinforced fill soils must meet the indicated criteria to be qualified for use in MSE construction using steel reinforcements.**

Table 3-3. Recommended Limits of Electrochemical Properties for Reinforced Fills with Steel Reinforcement.

<u>Property</u>	<u>Criteria</u>	<u>Test Method</u>
Resistivity	> 3000 ohm-cm	AASHTO T-288
pH	> 5 and < 10	AASHTO T-289
Chlorides	< 100 PPM	ASMT D4327
Sulfates	< 200 PPM	ASTM D4327
Organic Content	1% max.	AASHTO T-267

Table 3-4. Recommended Limits of Electrochemical Properties for Reinforced Fills with Geosynthetic Reinforcements (FHWA NHI-09-087, Elias et al., 2009).

<u>Base Polymer</u>	<u>Property</u>	<u>Criteria</u>	<u>Test Method</u>
Polyester (PET)	pH	$3 < \text{pH} < 9$	AASHTO T-289
Polyolefin (PP & HDPE)	pH	$\text{pH} > 3$	AASHTO T-289

Where geosynthetic reinforcements are planned, the limits for electrochemical criteria will vary depending on the polymer. Limits, based on current research, are shown in Table 3-4.

3.3 REINFORCED SOIL CONCEPTS

A reinforced soil mass is somewhat analogous to reinforced concrete in that the mechanical properties of the mass are improved by reinforcement placed parallel to the principal strain direction to compensate for soil's lack of tensile resistance. The improved tensile properties are a result of the interaction between the reinforcement and the soil. The composite material has the following characteristics:

- Stress transfer between the soil and reinforcement takes place continuously along the reinforcement.
- Reinforcements are distributed throughout the soil zone with a degree of regularity. localized.

3.3.1 Stress Transfer Mechanisms

Stresses are transferred between soil and reinforcement by friction (Figure 3-2a) and/or passive resistance (Figure 3-2b) depending on the reinforcement geometry.

Friction develops at locations where there is a relative shear displacement and corresponding shear stress between soil and the reinforcement surface. Reinforcing elements dependent on friction should be aligned with the direction of soil reinforcement relative movement. Examples of such reinforcing elements are steel strips, longitudinal bars in grids, geotextile, geosynthetic straps, and some geogrid layers.

Passive resistance occurs through the development of bearing type stresses on "transverse" reinforcement surfaces normal to the direction of soil reinforcement relative movement. Passive resistance is generally considered to be the primary interaction for bar mat, wire mesh reinforcements, and geogrids with relatively stiff cross machine direction ribs. The transverse ridges on "ribbed" strip reinforcement also provide some passive resistance.

The contribution of each transfer mechanism for a particular reinforcement will depend on the roughness of the surface (skin friction), normal effective stress, grid opening dimensions, thickness of the transverse members, and elongation characteristics of the reinforcement. Equally important for interaction development are the soil characteristics, including grain size, grain size distribution, particle shape, density, water content, cohesion, and stiffness.

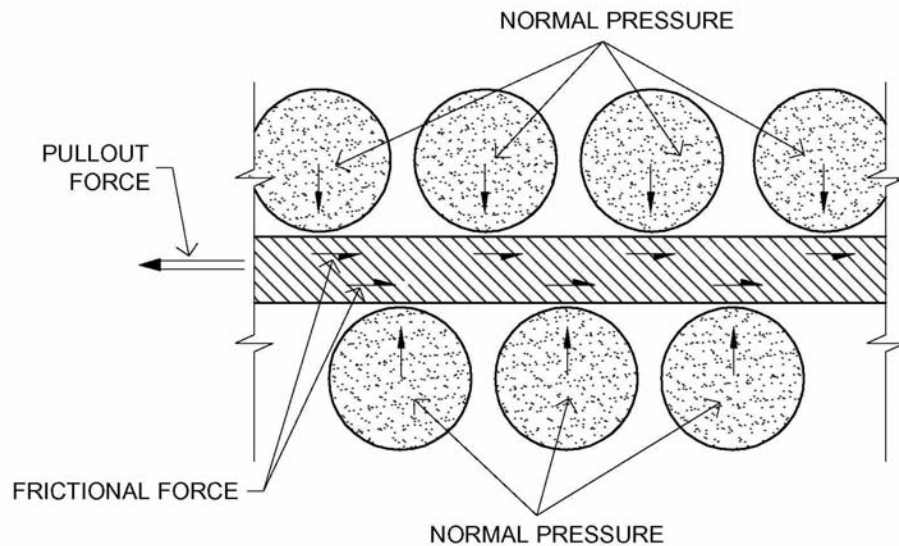

A) Frictional Stress Transfer Between Soil and Reinforcement Surfaces.

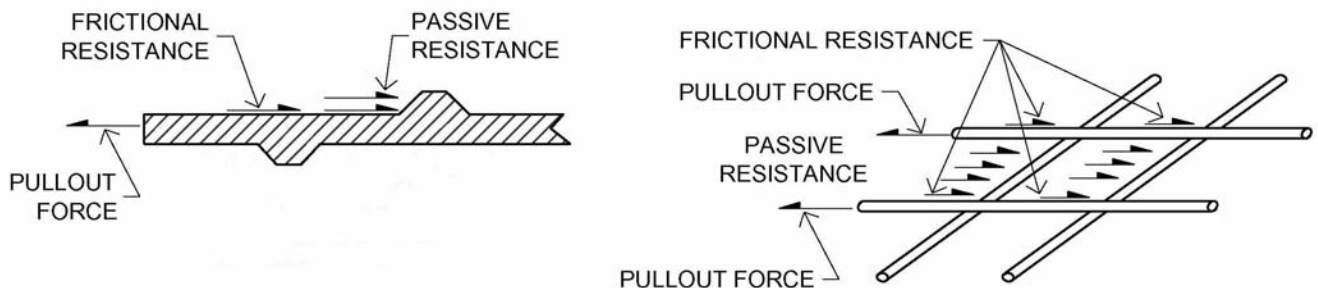

B) Soil Passive (Bearing) and Frictional Resistance on Reinforcement Surfaces.

Figure 3-2. Stress transfer mechanisms for soil reinforcement.

3.3.2 Mode of Reinforcement Action

The primary function of reinforcements is to restrain soil deformations. In so doing, stresses are transferred from the soil to the reinforcement. These stresses are resisted by the reinforcement tension and/or shear and bending.

- **Tension** is the most common mode of action of tensile reinforcements. All "longitudinal" reinforcing elements (i.e., reinforcing elements aligned in the direction of soil extension) are generally subjected to high tensile stresses. Tensile stresses are also developed in flexible reinforcements that cross shear planes.
- **Shear and Bending.** "Transverse" reinforcing elements that have some rigidity, can withstand shear stress and bending moments.

3.3.3 Geometric Characteristics

Two types can be considered:

- **Strips, bars, and steel grids.** A layer of steel strips, bars, or grids is characterized by the cross-sectional area, the thickness and perimeter of the reinforcement element, and the center-to-center horizontal distance between elements (for steel grids, an element is considered to be a longitudinal member of the grid that extends into the wall).
- **Geotextiles and geogrids.** A layer of geosynthetic strips is characterized by the width of the strips and the center-to-center horizontal distance between them. The cross-sectional area is not needed, since the strength of a geosynthetic strip is expressed by a tensile force per unit width, rather than by stress. Difficulties in measuring the thickness of these thin and relatively compressible materials preclude reliable estimates of stress.

The coverage ratio R_c is used to relate the force per unit width of discrete reinforcement to the force per unit width required across the entire structure. See Figure 3-3 (and later Figure 3-5) for an illustration of these terms.

$$R_c = \frac{b}{S_h} \quad (3-1)$$

where:

b = the gross width of the strip, sheet, or grid. For grids, b is measured from the center to center of the outside longitudinal bars as shown in Figure 3-3.

S_h = center-to-center horizontal spacing between strips, sheets, or grids

Note, $R_c = 1$ in the case of continuous reinforcement, i.e., each reinforcement layer covers the entire horizontal surface of the reinforced soil zone. Alternatively, for discrete reinforcements and segmental precast concrete facing, force per width may be more conveniently calculated per panel width, as defined later in Equation 4-25c, for layout and detailing.

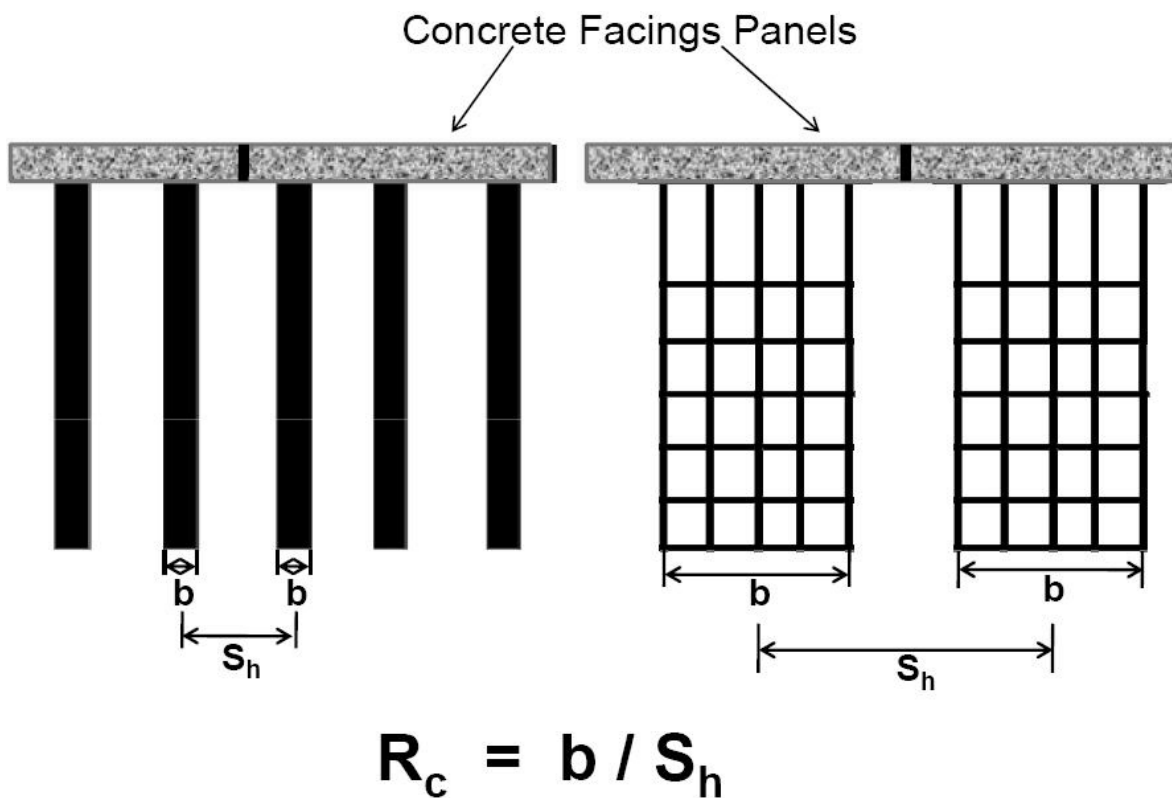

Figure 3-3. Coverage ratio.

3.4 SOIL REINFORCEMENT INTERACTION USING NORMALIZED CONCEPTS

Soil-interaction (pullout capacity) coefficients have been developed by laboratory and field studies, using a number of different approaches, methods, and evaluation criteria. A unified normalized approach developed in a FHWA research project is detailed below.

3.4.1 Evaluation of Pullout Performance

The design of the soil reinforcement system requires an evaluation of the long-term pullout performance with respect:

- Pullout capacity, i.e., the pullout resistance of each reinforcement should be adequate to resist the factored tensile force in the reinforcement with a specified resistance factor (or factor of safety in the case of RSS).
- Allowable displacement, i.e., the relative soil-to-reinforcement displacement required to mobilize the design tensile force should be smaller than the allowable displacement.
- Long-term displacement, i.e., the pullout load should be smaller than the critical creep load.

The pullout resistance of the reinforcement is mobilized through one or a combination of the two basic soil-reinforcement interaction mechanisms, interface friction and passive soil resistance against transverse elements of reinforcements such as bar mats, wire meshes, or geogrids. The load transfer mechanisms mobilized by a specific reinforcement depends primarily upon its structural geometry (i.e., composite reinforcement such as grids, versus linear or planar elements, thickness of transverse elements, and aperture dimension). The soil-to-reinforcement relative movement required to mobilize the design tensile force depends mainly upon the load transfer mechanism, the extensibility of the reinforcement material, the soil type, and the confining pressure.

The long-term pullout performance (i.e., displacement under constant design load) is predominantly controlled by the creep characteristics of the soil and the reinforcement material. Soil reinforcement systems will generally not be used with cohesive soils susceptible to creep. Therefore, creep is primarily controlled by the type of reinforcement. Pullout performance in terms of the main load transfer mechanism, relative soil-to-reinforcement displacement required to fully mobilize the pullout resistance, and creep potential of the reinforcement in granular (and low plasticity cohesive) soils for generic reinforcement types is provided in Table 3-5.

Table 3-5. Reinforcement Pullout Performance in Granular and Cohesive Soils of Low Plasticity.

Generic Reinforcement Type	Major Load Transfer Mechanism	Range of Displacement at Specimen Front	Long Term Deformation
Inextensible strips			
Smooth	Frictional	0.05 in. (1.2 mm)	Noncreeping
Ribbed	Frictional + passive	0.5 in. (12 mm)	Noncreeping
Extensible composite plastic strips	Frictional	Dependent on reinforcement extensibility	Dependent on reinforcement structure and polymer creep
Extensible sheets			
Geotextiles	Frictional	Dependent on reinforcement extensibility (1 to 4 in.) {25 to 100 mm}	Dependent on reinforcement structure and polymer creep characteristics
Inextensible grids			
bar mats	Passive + frictional	0.5 to 2 in. (12 to 50 mm)	Noncreeping
welded wire meshes	Frictional + passive	0.5 to 2 in. (12 to 50 mm)	Noncreeping
Extensible grids			
Geogrids	Frictional + passive	Dependent on extensibility (1 to 2 in.) {25 to 50 mm}	Dependent on reinforcement structure and polymer creep characteristics
woven wire meshes	Frictional + passive	1 to 2 in. (25 to 50 mm)	Noncreeping

3.4.2 Estimate of the Reinforcement Pullout Capacity in MSE Structures

The pullout resistance of the reinforcement is defined by the ultimate tensile load required to generate outward sliding of the reinforcement through the reinforced soil zone. Several approaches and design equations have been developed and are currently used to estimate the pullout resistance by considering frictional resistance, passive resistance, or a combination of both. The design equations use different interaction parameters, so it is difficult to compare the pullout performance of different reinforcements for a specific application.

For design and comparison purposes, a normalized definition of pullout resistance will be used throughout the manual. The pullout resistance, P_r , at each of the reinforcement levels per unit width of reinforcement is given by:

$$P_r = F^* \alpha \sigma'_v L_e C \quad (3-2)$$

where:

- $L_e C$ = the total surface area per unit width of the reinforcement in the resistive zone behind the failure surface
- L_e = the embedment or adherence length in the resisting zone behind the failure surface
- C = the reinforcement effective unit perimeter; e.g., $C = 2$ for and sheets, and because the edges are neglected $C = 2$ for strips and grids
- F^* = the pullout resistance (or friction-bearing-interaction) factor
- α = a scale effect correction factor to account for a non linear stress reduction over the embedded length of highly extensible reinforcements, based on laboratory data (generally 1.0 for metallic reinforcements and 0.6 to 1.0 for geosynthetic reinforcements, see Table 3-6).
- σ'_v = the effective vertical stress at the soil-reinforcement interfaces.

The correction factor α depends, therefore, primarily upon the strain softening of the compacted granular backfill material, and the extensibility and the length of the reinforcement. For inextensible reinforcement, α is approximately 1, but it can be substantially smaller than 1 for extensible reinforcements. The α factor (a scale correction factor) can be obtained from pullout tests on reinforcements with different lengths as presented in Appendix B, or derived using analytical or numerical load transfer models which have been "calibrated" through numerical test simulations. In the absence of test data, $\alpha = 0.8$ for geogrids and $\alpha = 0.6$ for geotextiles (extensible sheets) is recommended (see Table 3-6).

Table 3-6. Summary of Pullout Capacity Design Parameters.

Reinforcement Type	S_{opt}	Grid Spacing	Tan ρ	F_q	α_β	α Default Value
Inextensible strips		NA	Obtain Tan ρ from tests, or use default values	NA	NA	1.0
Inextensible grids (bar mats and welded wire)	$\frac{t F_q}{2 \tan \phi}$	$S_t \leq S_{opt}$	Obtain Tan ρ from tests	NA	NA	1.0*
	$\frac{t F_q}{2 \tan \phi}$	$S_t > S_{opt}$	NA	Obtain F_q from tests, or use default values	$\frac{t}{2S_t}$	1.0*
Extensible grids with $\frac{\text{min. grid opening}}{d_{50}} > 1$	$\frac{t F_q}{2 \tan \phi}$	$S_t \leq S_{opt}$	Obtain Tan ρ from tests	NA	NA	0.8
	$\frac{t F_q}{2 \tan \phi}$	$S_t > S_{opt}$	NA	Obtain F_q from tests, or use default values	$\frac{f_b t}{2S_t}$	0.8
Extensible grids with $\frac{\text{min. grid opening}}{d_{50}} < 1$		NA	Obtain Tan ρ from tests	NA	NA	0.8
Extensible sheets		NA	Obtain Tan ρ from tests	NA	NA	0.6

NOTES:

(i) It is acceptable to use the empirical values provided in or referenced by this table to determine F^* in the absence of product and backfill specific test data, provided granular reinforced fill as specified in Table 3-1 for MSE walls is used and $C_u \geq 4$. For fill outside these limits, tests must be run.

(ii) Pullout testing to determine α is recommended if α shown in table is less than 1.0. These values of α represent highly extensible geosynthetics.

(iii) For grids where Tan ρ is applicable, apply Tan ρ to the entire surface area of the reinforcement sheet (i.e., soil and grid), not just the surface area of the grid elements.

(iv) NA means "not applicable." ϕ is the soil friction angle. ρ is the interface friction angle mobilized along the reinforcement. S_{opt} is the optimum transverse grid element spacing to mobilize maximum pullout resistance as obtained from pullout tests (typically 6 in. (150 mm) or greater). S_t is the spacing of the transverse grid elements. t is the thickness of the transverse elements. F_q is the embedment (or surcharge) bearing capacity factor. α_β is a structural geometric factor for passive resistance. f_b is the fraction of the transverse member on which bearing can be fully developed (typically ranging from 0.6 to 1.0) as obtained from an evaluation of the bearing surface shape. D_{50} is the backfill grain size at 50% passing by weight. α is the scale effect correction factor.

(v) Definitions of the geometric variables are illustrated in Figure 3-4.

* For longitudinal bars/wires spacing greater than 6 inches, α may be less than 1.0 and pullout tests are required.

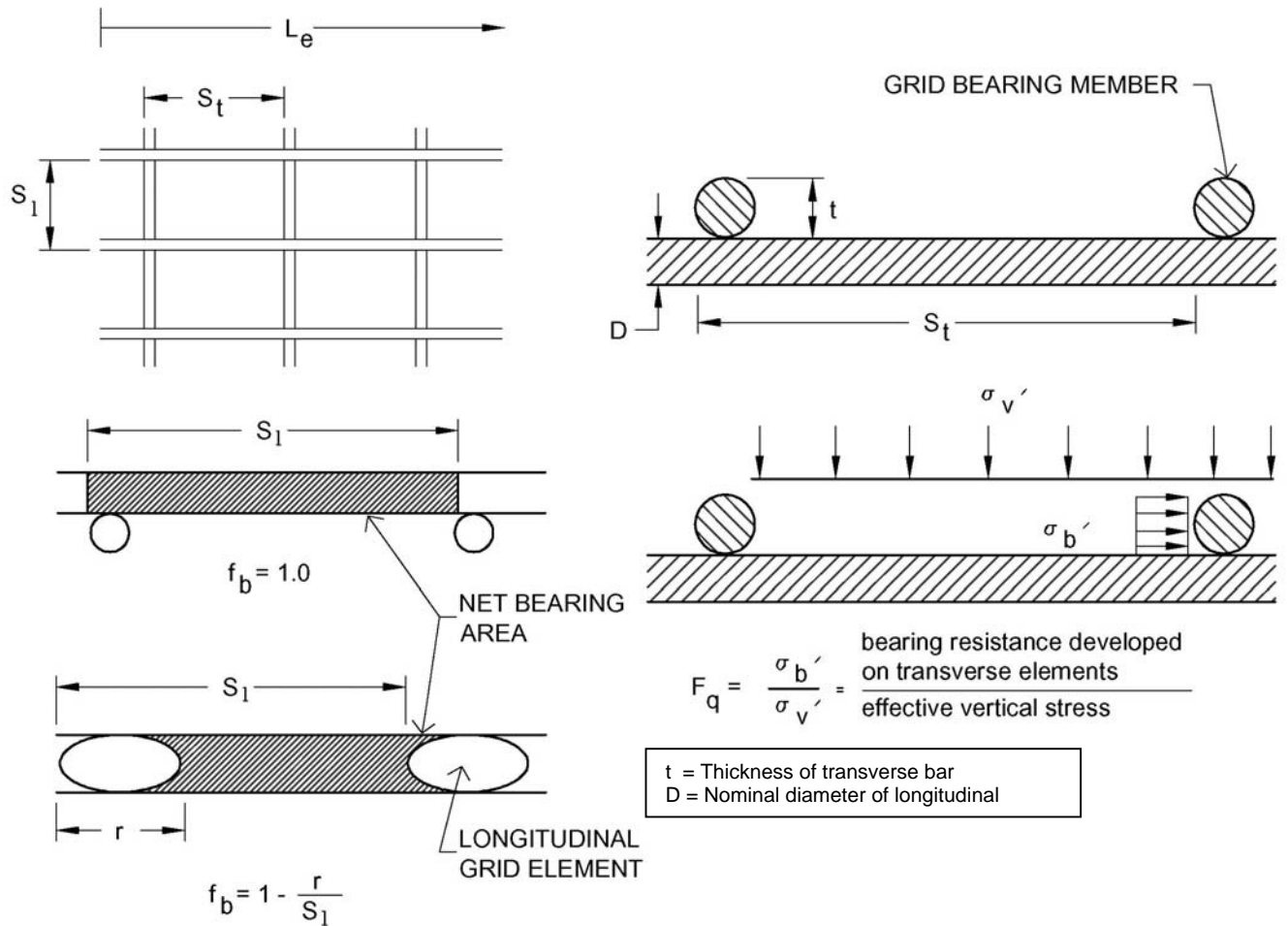

S_1 = Distance between longitudinal bars.

S_t = Distance between transverse bars.

Notes:

1. Transverse bar thickness does not need to be reduced for corrosion.
2. This is applicable up to a maximum transverse bar spacing of 24 in. (610 mm).

Figure 3-4. Definition of grid dimensions for calculating pullout capacity.

The Pullout Resistance Factor F^* can be obtained most accurately from laboratory or field pullout tests performed in the specific backfill to be used on the project. Test procedures for determining pullout parameters are presented in Appendix B. Alternatively, F^* can be derived from empirical or theoretical relationships developed for each soil-reinforcement interaction mechanism and provided by the reinforcement supplier. For any reinforcement, F^* can be estimated using the general equation:

$$F^* = \text{Passive Resistance} + \text{Frictional Resistance}$$

$$\text{or, } F^* = F_q \cdot \alpha_\beta + \tan \rho \quad (3-3)$$

where:

F_q = the embedment (or surcharge) bearing capacity factor

α_β = a bearing factor for passive resistance which is based on the thickness per unit width of the bearing member.

ρ = the soil-reinforcement interaction friction angle.

The pullout capacity parameters for Equation 3-3 are summarized in Table 3-6 and Figure 3-4 for the soil reinforcement systems considered in this manual.

A significant number of laboratory pullout tests have been performed for many commonly used reinforcement backfill combinations and correlated to representative field pullout tests. Therefore, the need for additional laboratory and/or field pullout tests, is generally limited to reinforcement/reinforced fill combinations where this data is sparse or nonexistent (e.g., uniform and marginal reinforced fill discussed in Section 3.1). Where applicable, laboratory pullout tests should be made in accordance with the device and procedures in ASTM D6706 and Appendix B of this manual. Note that this test procedure provides a short-term pullout capacity and does not account for soil or reinforcement creep deformations, which may be significant in MSE wall and RSS structures utilizing fine grained soil fills.

When using laboratory pullout tests to determine design parameters, vertical stress variations and reinforcement element configurations for the actual project should be used. Tests should be performed on samples with a minimum embedded length of 24 in. (600 mm). The pullout resistance is the greater of the peak pullout resistance value prior to, or the value achieved at, a maximum deformation of $\frac{3}{4}$ -in. (20 mm) as measured at the front of the embedded section for inextensible reinforcements and $\frac{5}{8}$ -in. (15 mm) as measured at the end of the embedded sample for extensible reinforcements. This allowable deflection criterion is based on a need to limit the structure deformations, which are necessary to develop sufficient pullout capacity.

Long-term pullout tests to assess soil/reinforcement creep behavior should be conducted when silt or clay reinforced fill is being used. Soil properties and reinforcement type will determine if the allowable pullout resistance is governed by creep deformations. The placement and compaction procedures for both short-term and long-term pullout tests should simulate field conditions. The allowable deformation criteria in the previous paragraph should be applied.

A summary of the procedures for evaluating laboratory tests to obtain pullout design parameters is outlined in Appendix B of this manual.

Most specialty system suppliers have developed recommended pullout parameters for their products when used in conjunction with the select backfill detailed in this chapter for MSEW and RSS structures. The semi-empirical relationships summarized below are consistent with results obtained from laboratory and field pullout testing at a 95 percent confidence limit, and generally consistent with suppliers developed data. Some additional economy can be obtained from site/product specific testing, where the source of the backfill in the reinforced volume has been identified during design.

In the absence of site-specific pullout testing data, it is reasonable to use the semi-empirical relationships described in the following paragraphs in conjunction with the standard specifications for reinforced fill to provide a conservative evaluation of pullout resistance.

For steel ribbed reinforcement, the Pullout Resistance Factor F^* is commonly taken as:

$$F^* = \tan \rho = 1.2 + \log C_u \text{ at the top of the structure} = 2.0 \text{ maximum} \quad (3-4)$$

$$F^* = \tan \phi \text{ at a depth of 20 ft (6 m) and below} \quad (3-5)$$

where C_u is the uniformity coefficient of the backfill (D_{60}/D_{10}). **If the specific C_u for the wall backfill is unknown at design time, a $C_u = 4$ should be assumed (i.e., $F^* = 1.8$ at the top of the wall) for reinforced fills meeting the requirements of Section 3.1 of this chapter.**

For steel grid reinforcements with transverse spacing of $S_t \geq 6$ inches (150 mm) (see Figure 3-4), F^* is a function of a bearing or embedment factor, F_q , applied over the contributing bearing α_β , as follows:

$$F^* = F_q \alpha_\beta = 40 \alpha_\beta = 40 (t/2S_t) = 20 (t/S_t) \text{ at the top of the structure} \quad (3-6)$$

$$F^* = F_q \alpha_\beta = 20 \alpha_\beta = 20 (t/2S_t) = 10 (t/S_t) \text{ at a depth of 20 ft (6 m) and below} \quad (3-7)$$

Where, t is the thickness of the transverse bar. S_t must be uniform throughout the length of the reinforcement rather than having transverse grid members concentrated only in the resistant zone. The maximum S_t distance is 24 in. (610 mm). For sloping backfills see Figure 4-15.

For geosynthetic (i.e., geogrid and geotextile) sheet reinforcement, the pullout resistance is based on a reduction in the available soil friction with the reduction factor often referred to as an Interaction Factor, C_i . In the absence of test data, the F^* value for geosynthetic reinforcement should conservatively be taken as:

$$F^* = \frac{2}{3} \tan \phi \quad (3-8)$$

Where used in the above relationships, ϕ is the peak friction angle of the soil which for MSE walls using select granular backfill, is taken as a maximum of 34 degrees unless project specific test data substantiates higher values. For RSS structures, the ϕ angle of the reinforced backfill is normally established by test, as a reasonably wide range of backfills can be used. A lower bound value of 28 degrees is often used.

3.4.3 Interface Shear

The interface shear between sheet type geosynthetics (geotextiles, geogrids and geocomposite drains) and the soil is often lower than the friction angle of the soil itself and can form a slip plane. Therefore the interface friction coefficient $\tan \rho$ must be determined in order to evaluate sliding along the geosynthetic interface with the reinforced fill and, if appropriate, the foundation or retained backfill soil. The interface friction angle ρ is determined from soil-geosynthetic direct shear tests in accordance with ASTM D 5321. In the absence of test results, the interface friction coefficient can be conservatively taken as:

$$\rho = \frac{2}{3} \tan \phi \quad (3-9)$$

for geotextiles, geogrids and geonet type drainage composites. Other geosynthetics such as geomembranes and some geocomposite drain cores may have much lower interface values and tests should accordingly be performed.

3.5 ESTABLISHMENT OF STRUCTURAL DESIGN PROPERTIES

The structural design properties of reinforcement materials are a function of geometric characteristics, strength and stiffness, durability, and material type. The two most commonly used reinforcement materials, steel and geosynthetics, must be considered separately as follows:

3.5.1 Strength Properties of Steel Reinforcements

For steel reinforcements, the design life is achieved by reducing the cross-sectional area of the reinforcement used in design calculations by the anticipated corrosion losses over the design life period as follows:

$$E_c = E_n - E_R \quad (3-10)$$

where E_c is the thickness of the reinforcement at the end of the design life, E_n the nominal thickness at construction, and E_R the sacrificial thickness of metal expected to be lost by uniform corrosion during the service life of the structure.

The nominal long-term tensile strength of the reinforcement, T_{al} , is obtained for steel strips and grids as shown in the following equations. T_{al} in units force per unit width is used to provide a unified strength approach, which can be applied to any reinforcement. Tensile strength of a known steel or grid reinforcement can also be expressed in terms of the tensile load carried by the reinforcement, P_{tal} . The desired designation of reinforcement tensile strength (T_{al} or P_{tal}) varies depending on whether one is designing with a known system, designing with an undefined reinforcement, checking a design layout, performing connection design, or performing reinforcement pullout calculations. Thus, nominal tensile strength may be calculated and expressed in the following terms:

$$T_{al} = \frac{F_y A_c}{b} \quad (\text{in strength per unit reinforcement width \{kips/ft\}}) \quad (3-11a)$$

$$P_{tal} = F_y A_c \quad (\text{in strength per reinforcement element \{kips\}}) \quad (3-11b)$$

where:

b = the gross width of the strip, sheet or grid (see Figure 3-5)

F_y = yield stress of steel

A_c = design cross section area of the steel, defined as the original cross section area minus corrosion losses anticipated to occur during the design life of the wall.

The LRFD resistance factors for steel reinforcements in MSE walls are listed in Table 4-8. The resistance factor for strip reinforcements under static conditions is 0.75. The resistance factors for steel grid MSE wall reinforcements, for static loading, is 0.65 when reinforcement is connected to a rigid facing element and is 0.75 when connected to a flexible facing. The lower resistance factor for grid reinforcing members connected to a rigid facing element (e.g., a concrete panel or block) is used to account for the greater potential for local overstress due to load nonuniformities for steel grids than for steel strips or bars. Transverse and longitudinal grid members are sized in accordance with ASTM A185.

The quantities needed to determine A_c for steel strips and grids are shown in Figure 3-5. Typical dimensions for common steel reinforcements are provided in Appendix C. The use of hardened and otherwise low strain (very high strength) steels may increase the potential for catastrophic failure; therefore, a lower resistance factor may be warranted with such materials.

For metallic reinforcement, the life of the structure will depend on the corrosion resistance of the reinforcement. Practically all the metallic reinforcements used in construction of embankments and walls, whether they are strips, bar mats, or wire mesh, are made of galvanized mild steel. Woven meshes with PVC coatings provide some corrosion protection, provided the coating is not significantly damaged during construction. Epoxy coatings can be used for corrosion protection, but are susceptible to construction damage, which can significantly reduce the coatings effectiveness. When PVC or epoxy coatings are used, the maximum particle size of the backfill should be restricted to $\frac{3}{4}$ -inch (19 mm) or less to reduce the potential for construction damage. For a more detailed discussion of requirements, refer to the Corrosion/Degradation manual, FHWA NHI-09-087 (Elias et al., 2009).

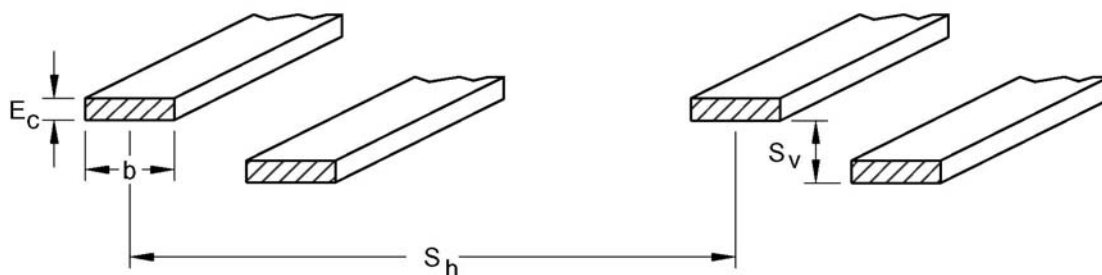

$$A_c = b E_c$$

E_c = strip thickness corrected for corrosion loss.

(a)

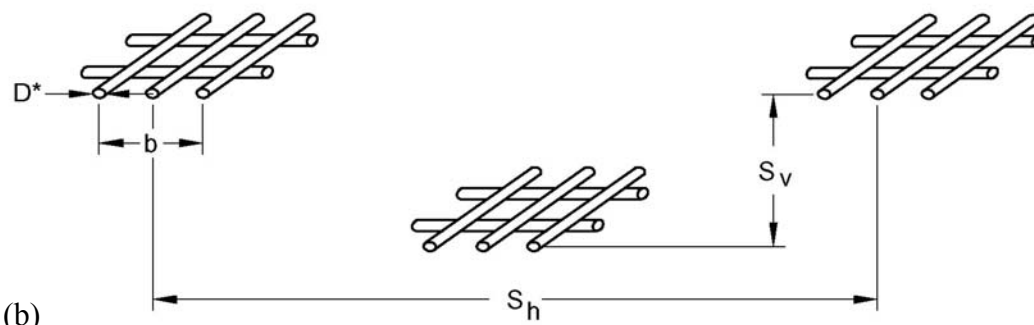

(b)

$$A_c = (\text{No. of longitudinal bars}) \times \left(\frac{(D^*)^2}{4} \right)$$

D^* = Diameter of bar or wire corrected for corrosion loss

b = Unit width of reinforcement (if reinforcement is continuous count the number of bars for reinforcement width of 1 unit)

$$T_{max} = \phi R_c T_{al} = \frac{\phi R_c F_y A_c}{b}$$

where T_{max} = Maximum factored load applied to reinforcement (load/unit wall width)

T_{al} = Nominal long-term tensile strength of the reinforcement (strength/unit reinforcement width)

ϕ = 0.75 for steel strip

ϕ = 0.65 for steel grid and rigid face

F_y = Yield strength of steel

R_c = Reinforcement coverage ratio = $\frac{b}{S_h}$

Use R_c = 1 for continuous reinforcement (i.e., $S_h = b = 1$ unit width)

Figure 3-5. Parameters for metal reinforcement nominal strength calculations showing (a) steel strips and (b) metallic grids and bar mats.

Several DOTs have used resin-bonded epoxy coated steel reinforcing elements. The effectiveness of these coatings in MSE wall structures has not been well documented. If used, the minimum coating thickness should be on the order of 18 mils (45 μm), and applied in accordance with ASTM A884 for grid reinforcement and AASHTO M284 for strip reinforcement. The in-ground design life of the coating should be considered as equal to that of a galvanized reinforcement with a coating thickness of 3.4 mils (85 μm), unless durability exposure testing has been performed on the specific coating that identifies a longer effective life as discussed in FHWA NHI-09-087 (Elias et al., 2009). Where other metals, such as aluminum alloys or stainless steel have been used, corrosion, unexpectedly, has been a severe problem, and their use has been discontinued.

The in-ground degradation resistance of PVC coated mesh has not been sufficiently demonstrated. Anecdotal evidence of satisfactory performance in excess of 25 years does not exist.

Extensive studies have been made to determine the rate of corrosion of galvanized mild steel bars or strips buried in different types of soils commonly used in reinforced soil. Based on these studies, deterioration of steel strips, mesh, bars and mats can be estimated and accounted for by using increased metal thickness.

The majority of MSE walls constructed to date have used galvanized steel and backfill materials with low corrosive potential. A minimum galvanization coating of 2.0 oz/ft² (605 g/m²) or 3.4 mils (85 μm) thickness is required per Article 11.10.6.4.2a (AASHTO, 2007). Galvanization shall be applied in accordance with AASHTO M 111 (ASTM A 123) for strip type, bar mat, or grid type reinforcements and ASTM A 153 for accessory parts such as bolts and tie strips. Galvanization shall be applied after fabrication in accordance with ASTM A123. The zinc coating provides a sacrificial anode that corrodes while protecting the base metal. Galvanization also assists in preventing the formation of pits in the base metal during the first years of aggressive corrosion (which can occur in non-galvanized or “black” steel). After the zinc is oxidized (consumed), corrosion of the base metal starts.

The ASTM and AASHTO standards for galvanization provide different required minimum galvanization coating thickness as a function of the bar or wire thickness. However, as noted previously AASHTO (2007) requires a minimum thickness of 3.4 mils (85 μm) for MSE walls. Galvanization requirements using this minimum and AASHTO M 111 are summarized in Table 3-7.

Table 3-7. Minimum Galvanization Thickness by Steel Thickness
(after AASHTO M 111 and ASTM A123).

Category	Steel Thickness	Minimum Galvanization Thickness
Strip	< ¼ in. (6.4 mm)	3.4 mils (85 µm)
	> ¼ in. (6.4 mm)	3.9 mils (100 µm)
Wire*	All diameters	3.4 mils (85 µm)
* For bar mats fabricated from uncoated steel wire.		

The corrosion rates presented in Table 3-8 are suitable for conservative design. **These rates assume a moderately corrosive backfill material having the controlled electrochemical property limits** that are discussed under electrochemical properties in this chapter.

Table 3-8 Steel Corrosion Rates for Moderately Corrosive Reinforced Fill.

For zinc/side:	0.58 mils/yr (15 µm/year) (first 2 years)
	0.16 mils/yr (4 µm/year) (thereafter)
For residual carbon steel/side:	0.47 mils/yr (12 µm/year) (thereafter)

Based on these rates, complete corrosion of galvanization with the minimum required thickness of 3.4 mils (85 µm) (AASHTO, 2007) is estimated to occur during the first 16 years and a carbon steel thickness or diameter loss of 0.055 in. to 0.08 in. (1.42 mm to 2.02 mm) would be anticipated over the remaining years of a 75 to 100 year design life, respectively. Galvanization can also be damaged during handling and construction by abrasion, scratching, notching, and cracking. Care must be taken during handling and construction to avoid damage. Construction equipment should not travel directly on reinforcing elements and elements should not be dragged, excessively bent, or field cut. Galvanized reinforcement should be well supported during lifting and handling to prevent excessive bending. Any damaged section should be field repaired by coating the damaged area with a field grade zinc-rich paint.

The look of galvanized WWM face may not be desired on some projects due to aesthetic requirements. As previously noted, black (ungalvanized) steel is not allowed on permanent structures. Staining of galvanized WWM has been used to achieve desired aesthetics on some projects.

The designer of an MSE structure should also consider the potential for changes in the reinforced fill environment during the structure's service life. In certain parts of the United States, it can be expected that deicing salts, coastal storm surges, or contaminated runoff or groundwater might cause such an environment change. For this problem, the depth of chloride infiltration and concentration are of concern such that additional protective measures may be required.

For permanent structures directly supporting roadways exposed to deicing salts, limited data indicate that the upper 8 ft (2.5 m) of the reinforced backfill (as measured from the roadway surface) or greater depths, depending on the gradation and compaction of the fill, are affected by higher corrosion rates not presently defined. Under these conditions, it is recommended that a 30 mil (minimum) geomembrane be placed below the road base and tied into a drainage system to mitigate the penetration of the deicing salts in lieu of higher corrosion rates as shown in the Design Details section in Chapter 5. Alternatively free draining reinforced fill (e.g., AASHTO No. 57 stone) has also been found to allow salts to “flush out” and limit corrosion as discussed in FHWA NHI-09-087 (Elias et al., 2009). Note that value of “higher” corrosion rate for deicing salt exposure is not defined.

The following project situations lie outside the scope of the previously presented values:

- Structures exposed to a marine or other chloride-rich environment. (Excluding locations where de-icing salts are used.) For marine saltwater structures, carbon steel losses on the order of 3.2 mils (80 μm) per side or radius should be anticipated in the first few years, reducing to 0.67 to 0.7 mils (17 to 20 μm) thereafter. Zinc losses are likely to be quite rapid as compared to losses in reinforced fills meeting the MSE electrochemical criteria. Total loss of zinc (3.4 mils {85 μm }) should be anticipated in the first year.
- Structures exposed to stray currents, such as from nearby underground power lines, and structures supporting or located adjacent to electrical railways.
- Structures exposed to acidic water emanating from mine waste, abandoned coal mines, or pyrite-rich soil and rock strata.

Each of these situations creates a special set of conditions that should be specifically analyzed by a corrosion specialist.

3.5.2 Strength Properties of Geosynthetic Reinforcement

Selection of long-term nominal tensile strength, T_{al} , for geosynthetic reinforcement is determined by thorough consideration of all possible strength time dependent strength losses over the design life period. The tensile properties of geosynthetics are affected by factors such as creep, installation damage, aging, temperature, and confining stress. Furthermore, characteristics of geosynthetic products manufactured with the same base polymer can vary widely requiring a T_{al} determination for each individual product with consideration of all these factors.

Polymeric reinforcement, although not susceptible to corrosion, may degrade due to physicochemical activity in the soil such as hydrolysis, oxidation, and environmental stress cracking depending on polymer type. In addition, these materials are susceptible to installation damage and the effects of high temperature at the facing and connections. Temperature acts to accelerate creep and aging processes and temperature effects are accounted for through their determination. While the normal range of in-ground temperature vary from 55° F (12° C) in cold and temperate climates to 85° F (30° C) in arid desert climates, temperatures at the facing and reinforcement connections can be as high as 120° F (50° C). Confining stress is not directly taken into account other than indirectly when installation damage is evaluated. For creep and durability, confining stress generally will tend to improve the long-term strength of the reinforcement.

The available long-term strength, T_{al} , is calculated as follows:

$$T_{al} = \frac{T_{ult}}{RF} = \frac{T_{ult}}{RF_{ID} \times RF_{CR} \times RF_D} \text{ (in strength per unit reinforcement width)} \quad (3-12)$$

where,

T_{ult} = Ultimate Tensile Strength (strength per unit width). The tensile strength of the reinforcement is determined from wide strip tests per ASTM D4595 (geotextiles) or D6637 (geogrids) based on the minimum average roll value (MARV) for the product.

RF = Reduction Factor. The product of all applicable reduction factors.

RF_{ID} = Installation Damage Reduction Factor. A reduction factor that accounts for the damaging effects of placement and compaction of soil or aggregate over the

geosynthetic during installation. A minimum reduction factor of 1.1 should be used to account for testing uncertainties.

RF_{CR} = Creep Reduction Factor. A reduction factor that accounts for the effect of creep resulting from long-term sustained tensile load applied to the geosynthetic.

RF_D = Durability Reduction Factor. A reduction factor that accounts for the strength loss caused by chemical degradation (aging) of the polymer used in the geosynthetic reinforcement (e.g., oxidation of polyolefins, hydrolysis of polyesters, etc.).

RF_{ID} , RF_{CR} , and RF_D reflect actual long-term strength losses, analogous to loss of steel strength due to corrosion. This long-term geosynthetic reinforcement strength loss concept is illustrated in Figure 3-6. As shown in the figure, some strength losses occur immediately upon installation, and others occur throughout the design life of the reinforcement. Much of the long-term strength loss does not begin to occur until near the end of the reinforcement design life.

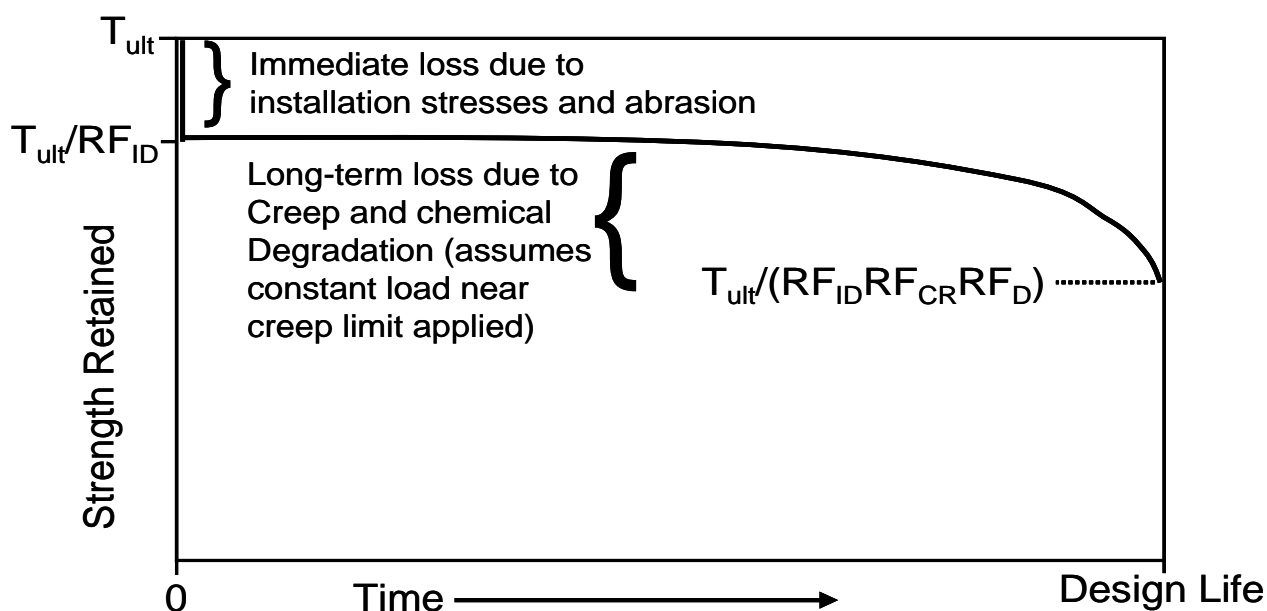

Figure 3-6. Long-term geosynthetic reinforcement strength concepts.

Because of varying polymer types, quality, additives and product geometry, each geosynthetic is different in its resistance to aging and attack by different chemical agents. Therefore, each product must be investigated individually, or in the context of product line where the same polymer source and additives are used, and the manufacturing process is the same for all products in the product line. This product line approach makes it possible to interpolate reduction factors for products in the product line not specifically tested using the reduction factors determined for the products in the product line that are specifically tested for each degradation mechanism.

The AASHTO LRFD Bridge Design Specifications provide minimum requirements for the assessment of T_{al} for use in the design of geosynthetic reinforced soil structures. Protocols for evaluating T_{al} are included in Appendix D with supporting information on testing procedures provided in the companion Corrosion/Degradation document (Elias et al., 2009).

It is recommended that T_{al} values for specific products be determined from in-house, agency evaluation or third-party evaluation of independent test results such as the Highway Innovative Technology Evaluation Center (HITEC) or AASHTO National Transportation Product Evaluation Program (NTPEP). Agencies can approve reduction factors and allowable strength values based these reports or require that vendor designs use reduction factors substantiated by these or equivalent third party reports. Alternatively, T_{al} could be obtained directly from the manufacturer based on independent test results, though third party testing is the preferred approach. If manufacturer data is used, it should meet the same standard of quality and completeness that can be obtained from the third party testing programs such as NTPEP, and the designer should check to make sure that the manufacturer data are representative of the products likely to be received at the project site (i.e., the product test data should be current, and the product manufacturing process, polymer source, etc., should not have changed since the testing was conducted). In all cases, the geosynthetic product line must be reevaluated on a periodic to assess any changes that may affect the product and corresponding reduction values (e.g., NTPEP requires that the geosynthetic reinforcement product/product line be retested every 3 years).

In lieu of third party testing or manufacturer generated data, in-house agency testing to establish T_{al} with regard to the full suite of tests is generally not practical. However, agencies are encouraged to at least perform some of the index testing themselves, both for product qualification purposes (i.e., development of a qualified product or approved products list) as well as project specific product acceptance purposes. Agencies should also consider site specific installation damage testing, especially if relatively coarse, uniformly graded crushed or otherwise angular aggregate is used as backfill, or if other relatively severe installation conditions are anticipated.

The determination of reduction factors for each geosynthetic product and product line requires extensive field and/or laboratory testing which can take a year or more to complete. Background regarding the determination of each long-term strength reduction factor is briefly summarized as follows:

3.5.2.a Ultimate Tensile Strength, T_{ult}

The value selected for T_{ult} , for design purposes, is the minimum average roll value (MARV) for the product. This minimum average roll value, accounts for statistical variance in the material strength. Other sources of uncertainty and variability in the long-term strength result from installation damage, creep extrapolation, and the chemical degradation process. It is assumed that the observed variability in the creep rupture envelope is 100% correlated with the short-term tensile strength, as the creep strength is typically directly proportional to the short-term tensile strength within a product line. Therefore, the MARV of T_{ult} adequately takes into account variability in the creep strength. Note that the MARV of T_{ult} is the minimum certifiable wide width tensile strength provided by the product manufacturer.

3.5.2.b Installation Damage Reduction Factor, RF_{ID}

Damage during handling and construction, such as from abrasion and wear, punching and tear or scratching, notching, and cracking may occur in geosynthetics. These types of damage can only be avoided by using care during handling and construction. Construction equipment should not travel directly on geosynthetic materials.

Damage during reinforced fill placement and compaction operations is a function of the severity of loading imposed on the geosynthetic during construction operations and the size and angularity of the reinforced fill. For MSE walls and RSS construction, lightweight, low strength geotextiles and geogrids should be avoided to minimize damage with ensuing loss of strength.

Protocols for field testing for this reduction factor are detailed in the companion Corrosion/Degradation document (Elias et al., 2009) and in ASTM D-5818 (see also WSDOT T925). These protocols require that the geosynthetic material be subjected to a reinforced fill placement and compaction cycle, consistent with field practice. The ratio of the initial strength, to the strength of retrieved samples defines this reduction factor. For reinforcement applications, a minimum weight of 8.0 oz/yd² (270 g/m²) for geotextiles is recommended to minimize installation damage. This roughly corresponds to a Class 1 geotextile as specified in AASHTO M 288. In general, the combination of geosynthetic reinforcement, and backfill placement and gradation characteristics, should not result in a value of RF_{ID} greater than 1.7. If testing indicates that RF_{ID} will be greater than 1.7 (approximately a 40 percent strength loss), that combination of geosynthetic and backfill

conditions should not be used, as this or greater levels of damage will cause the remaining strength to be highly variable and therefore not adequately reliable for design.

Table 3-9 provides a summary of typical RF_{ID} values for a range of soil gradations and geosynthetic types.

In general, RF_{ID} is strongly dependent on the backfill soil gradation characteristics and its angularity, especially for lighter weight geosynthetics. Provided a minimum of 6 inches of backfill material is placed between the reinforcement surface and the compaction and spreading equipment wheels/tracks, the backfill placement and compaction technique will have a lesser effect on RF_{ID} . Regarding geosynthetic characteristics, the geosynthetic weight/thickness or tensile strength may have a significant effect on RF_{ID} . However, for coated polyester geogrids, the coating thickness may overwhelm the effect of the product unit weight or thickness on RF_{ID} .

Table 3-9. Installation Damage Reduction Factors.

Reduction Factor, RF_{ID}		
Geosynthetic	Type 1 Backfill Max. Size 4 in. (100mm) D_{50} about 1¼-in. (30 mm)	Type 2 Backfill Max. Size ¾ -in. (20mm) D_{50} about #30 (0.7 mm)
HDPE uniaxial geogrid	1.20 - 1.45	1.10 - 1.20
PP biaxial geogrid	1.20 - 1.45	1.10 - 1.20
PVC coated PET geogrid	1.30 - 1.85	1.10 - 1.30
Acrylic coated PET geogrid	1.30 - 2.05	1.20 - 1.40
Woven geotextiles (PP&PET) ^a	1.40 - 2.20	1.10 - 1.40
Non woven geotextiles (PP&PET) ^a	1.40 - 2.50	1.10 - 1.40
Slit film woven PP geotextile ^a	1.60 - 3.00	1.10 - 2.00

a. Minimum weight 8.0 oz/yd² (270 g/m²).

3.5.2.c Creep Reduction Factor, RF_{CR}

The creep reduction factor is required to limit the load in the reinforcement to a level known as the creep limit, that will preclude excessive elongation and creep rupture over the life of the structure. The creep limit strength is thus analogous to yield strength in steel. Creep is essentially a long-term deformation process. As load is applied, molecular chains move relative to each other through straightening out of folded or curved/kinked chains or through breaking of inter-molecular bonds, resulting in no strength loss, but increased elongation.

Eventually, if the load levels are sufficiently high i.e., constant load near the creep limit), the molecular chains can straighten/elongate no more without breaking the molecular chains. Significant strength loss occurs only when the straightening/slipping process is exhausted. If the load is high enough, molecular chains break, and both elongation and strength loss occur at an accelerating rate, eventually resulting in rupture. Generally this strength loss occurs only near the end of the design life of the geosynthetic under a given load level.

The creep reduction factor is obtained from long term laboratory creep testing as detailed in Appendix D. Creep testing is essentially a constant load test on multiple product samples, loaded to various percentages of the ultimate product load, for periods of up to 10,000 hours. For creep testing one of two approaches may be used: 1) “conventional” creep testing per ASTM D5262, or 2) a combination of Stepped Isothermal Method (SIM) per ASTM D6992, which is an accelerated method using stepped increases in temperature to allow tests to be performed in a matter of days, and “conventional” creep testing. The creep reduction factor is the ratio of the ultimate load to the extrapolated maximum sustainable load (i.e., creep rupture limit) within the design life of the structure (e.g., several years for temporary structures, 75 to 100 years for permanent structures).

Typical ranges of RF_{CR} as a function of polymer type are:

<u>Polymer Type</u>	<u>Creep Reduction Factors</u>
Polyester (PET)	2.5 to 1.6
Polypropylene (PP)	5 to 4.0
High Density Polyethylene (HDPE)	5 to 2.6

3.5.2.d Durability Reduction Factor, RF_D

This reduction factor is dependent on the susceptibility of the geosynthetic to attack by chemicals, thermal oxidation, hydrolysis, environmental stress cracking, and microorganisms, and can vary typically from 1.1 to 2.0.

Typically, polyester products (PET) are susceptible to aging strength reductions due to hydrolysis (water must be available). Hydrolysis and the resulting fiber dissolution are accelerated in alkaline regimes, percent of water saturation in the surrounding soil, and temperature. Polyolefin products (PP and HDPE) are susceptible to aging strength losses due to oxidation (contact with oxygen). The level of oxygen in reinforced fills is a function of soil porosity, groundwater location and other factors, and has been found to be slightly less than oxygen levels in the atmosphere (21 percent). Therefore, oxidation of geosynthetics in-ground may proceed at a rate equal those used above ground. Oxidation is accelerated by the presence of transition metals (Fe, Cu, Mn, Co, Cr) in the reinforced fill as found in acid sulphate soils (e.g., pyrite), slag and cinder fills, other industrial wastes or mine tailings

containing transition metals, and elevated temperature. It should be noted that the resistance of polyolefin geosynthetics to oxidation is primarily a function of the proprietary antioxidant package added to the base resin, which differs for each product brand, even when formulated with the same base resin.

The relative resistance of polymers to these identified regimes is shown in Table 3-10 and a choice can be made, therefore, consistent with the in-ground regimes indicated.

Table 3-10. Anticipated Resistance of Polymers to Specific Environments.

<u>Soil Environment</u>	<u>Polymer</u>		
	<u>PET</u>	<u>PE</u>	<u>PP</u>
Acid Sulphate Soils	NE	ETR	ETR
Organic Soils	NE	NE	NE
Saline Soils pH < 9	NE	NE	NE
Ferruginous	NE	ETR	ETR
Calcareous Soils	ETR	NE	NE
Modified Soils/Lime, Cement	ETR	NE	NE
Sodic Soils, pH > 9	ETR	NE	NE
Soils with Transition Metals	NE	ETR	ETR
NE =No Effect ETR =Exposure Tests Required			

Most geosynthetic reinforcement is buried, and therefore ultraviolet (UV) stability is only of concern during construction and when the geosynthetic is used to wrap the wall or slope face. If used in exposed locations, the geosynthetic should be protected with coatings or facing units to prevent deterioration. UV tests (ASTM D4355) extended beyond the normal 500 hour test duration should be performed on materials that will be directly exposed for long periods of time (more than several months) in order to evaluate the materials anticipated design life. Vegetative covers can also be considered in the case of open weave geotextiles or geogrids. Thick geosynthetics with ultraviolet stabilizers can be left exposed for several years or more without protection; however, long-term maintenance should be anticipated because of both UV deterioration and possible vandalism.

Protocols for testing to obtain this reduction factor have been proposed and are detailed in FHWA RD-97-144 (Elias et al. 1999). In general, for polyolefins, they consist of oven aging polyolefins (PP and HDPE) samples to accelerate oxidation and measure their strength reduction, as a function of time, temperature and oxygen concentration. This high

temperature data must then be extrapolated to a temperature consistent with field conditions. For polyesters (PET) the aging is conducted in an aqueous media at varying pHs and relatively high temperature to accelerate hydrolysis, with data extrapolated to a temperature consistent with field conditions. For more detailed explanations, see the companion Corrosion/Degradation manual, FHWA NHI-09-087 (Elias et al., 2009).

Due to the long-term nature of these durability evaluation protocols (2 to 3 years could be required to complete such tests), it is generally not practical to conduct such tests for typical geosynthetic reinforcement design, but are generally more suited for research activities. However, short-term index type tests can be conducted as indicators of good long-term durability performance, based on correlation to the long-term research results obtained and reported by Elias et al. (1999). Such index test results, combined with a criteria applied to the test results that can be considered to indicate good long-term performance, can be used to justify the use of a default value for RF_D that can be used for the determination of T_{al} .

The following recommendations are stated in this companion document in regards to defining a RF_D factor. With respect to aging degradation, current research results suggest the following.

Polyester Geosynthetics

PET geosynthetics are recommended for use only in environments characterized by $3 < \text{pH} < 9$. The reduction factors for PET aging (RF_D) listed in Table 3-11 are developed for a 100-year design life in the absence of long-term product specific testing. Based on these research results, for polyester reinforcement, the AASHTO LRFD specifications recommend a minimum number average molecular weight of 25,000 and a maximum carboxyl end group content (CEG) of 30 to allow the use of a default reduction factor for durability.

Polyolefin Geosynthetics

To mitigate thermal and oxidative degradative processes, polyolefin (i.e., PP and HDPE) products are stabilized by the addition of antioxidants for both processing stability and long-term functional stability. These antioxidant packages are proprietary to each manufacturer and their type, quantity, and effectiveness varies. Without residual antioxidant protection (after processing), PP products are vulnerable to oxidation and significant strength loss within a projected 75 to 100 year design life at 20°C. Current data suggests that unstabilized PP has a half-life of less than 50 years.

Table 3-11. Durability (Aging) Reduction Factors for PET.

Product ^a	Durability Reduction Factor, RF _D	
	5 ≤ pH ≤ 8	3 ^b < pH ≤ 5 8 ≤ pH < 9
Geotextiles M _n < 20,000, 40 < CEG < 50	1.6	2.0
Coated geogrids, Geotextiles M _n > 25,000, CEG < 30	1.15	1.3
M _n = number average molecular weight CEG = carboxyl end group <u>Notes:</u> a. Use of materials outside the indicated molecular property range requires specific product testing. Use of products outside of 3 < pH < 9 range is not recommended. b. Lower limit of pH for permanent applications is 4.5 and lower limit for temporary applications is 3, per Article 11.10.6.4.2b (AASHTO, 2007).		

Therefore the anticipated functional life of a PP geosynthetic is to a great extent a function of the type and post-production antioxidant levels, and the rate of subsequent antioxidant consumption. Antioxidant consumption is related to the in-ground oxygen content, which in fills is only slightly less than atmospheric.

A detailed discussion of the effectiveness of oven aging and other protocols to allow estimation of long-term strength loss due to the combination of heat aging and oxidative degradation of various polyolefins is provided in Elias et al. (1999) and Elias et al. (2009). At present, index tests and associated test result criteria that can be considered indicative of sufficient long-term durability consist of shorter-term relatively high temperature oven aging tests (ENV ISO 13438:1999 and UV degradation tests (i.e., ASTM D4355). The current AASHTO LRFD specifications currently only specify a requirement for the UV test as an indirect indicator of the presence of long-term residual antioxidant protection, requiring polyolefins to have a minimum of 70 percent strength retained after 500 hours in a weatherometer per ASTM D4355. In addition, in Europe and in the NTPEP testing program, oven aging test are also required to justify the use of a default value for RF_D for polyolefins.

For both polyester and polyolefins, if these index test criteria are met, a default value for RF_D of 1.3 could be used to determine T_{al} for design purposes. These index criteria are summarized in Table 3-12. If the effective in-soil site temperature is anticipated to be approximately 85° F (30° C) plus or minus a few degrees, a higher default reduction factor for RF_D should be considered.

Environmental stress cracking is an aging phenomenon that is really as much related to creep as it is to durability. In certain environments, such as when surfactants are present, the creep rupture process, through making it easier for the tie molecules to pull out of the crystalline structure, can be accelerated, allowing cracks in the polymer to form, and premature rupture. Additional information on this phenomenon is provided in Elias et al. (2009). For most in ground conditions, the chemicals necessary to cause this to happen are generally not present, and the results from laboratory creep testing are sufficient to address strength loss under constant load.

Table 3-12. Minimum Requirements for Use of Default Durability Reduction Factors (RF_D) for Primary Geosynthetic Reinforcement.

Type	Property	Test Method	Criteria to Allow Use of Default RF
Polypropylene and Polyethylene	UV Oxidation Resistance	ASTM D4355	Min. 70% strength retained after 500 hrs. in weatherometer
Polyester	UV Oxidation Resistance	ASTM D4355	Min. 50% strength retained after 500 hrs. in weatherometer if geosynthetic will be buried within one week, 70% if left exposed for more than one week
Polypropylene and Polyethylene	Thermo-Oxidation Resistance	ENV ISO 13438:1999, Method A (Polypropylene) or B (Polyethylene)	Min. 50% strength retained after 28 days (PP) or 56 days (HDPE)
Polyester	Hydrolysis Resistance	Inherent Viscosity Method (ASTM D4603 and GRI Test Method GG8), or Determine Directly Using Gel Permeation Chromatography	Min. Number (Mn) Molecular Weight of 25,000
Polyester	Hydrolysis Resistance	GRI GG7	Max. Carboxyl End Group Number of 30
All Polymers	Survivability	¹ Weight per Unit Area, ASTM D5261	Min. 8 oz/yd ² (270 g/m ²)
All Polymers	% Post Consumer Recycled Material by Weight	Certification of Material used	Maximum 0%

¹Alternatively, a default RF_D = 1.3 may be used if product specific installation damage testing is performed and it is determined that RF_{ID} is 1.7 or less, and if the other requirements in Table 3-12 are met.

Note that biological degradation due to micro-organisms is rarely a concern, as most geosynthetic reinforcement products only contain high molecular weight polymers, and the biological agents have great difficulty in finding the molecular chain endings that would allow them to begin consuming the polymer. Therefore, biological degradation is usually not considered in the determination of RF_D .

3.5.2.e Durability Reduction Factor, RF_D , at Wall Face Unit

As noted in Section 4.4.7.i Connection Strength, the long-term environmental aging factor (RF_D) may be significantly different than that used in computing the in-soil nominal long-term reinforcement strength T_{al} . For these applications, it is recommended that the use of polyesters be limited to a pH range of > 3 and < 9 , as noted in Table 3-11.

Of particular concern is the use of polyester geogrid and geotextile reinforcements with concrete facings because of the potential high pH environment. PET geogrids and geotextiles should not be cast into concrete for connections, due to the potential for chemical degradation.

Use of PET reinforcements connected to dry-cast MBW units by laying the reinforcement between units may be subject to additional strength reductions. An FHWA sponsored field monitoring study to examine pH conditions within and adjacent to MBW units was performed (Koerner et al., 2000), which provided a large database of pH measurements of 25 MSE wall structures in the United States. The results indicated that the pH regime within the blocks in the connection zone is only occasionally above 9 and then for only the first few years. The pH subsequently decreases to the pH of the ambient backfill (Koerner et al., 2000). It therefore appears that for coated PET geogrids no further reduction is warranted. For geotextiles a small further reduction should be considered to account for a few years at a pH in excess of 9.

Caution is advised in situations where the MBW units will be saturated for extended periods of time such as structures in lakes or streams. For such cases, long-term pH tests should be performed on saturated block. If the pH exceeds 9, polyester reinforcements should not be used in the section of the structure.

3.5.2.f LRFD Geosynthetic Reinforcement Resistance Factor, ϕ

The resistance factor for geosynthetic reinforcement accounts for potential of local overstress due to load nonuniformity and uncertainties in long-term reinforcement strength. For Strength I limit state conditions, a resistance factor (ϕ) equal to 0.90 is used for geosynthetic reinforcements (see Table 4-7). This is higher than the resistance factors for steel reinforcements due to the ductile nature of geosynthetic systems at failure.

The recommended resistance factor of ϕ of 0.90 can be further justified by considering the following:

- For geosynthetic reinforcements, the reinforced fill soil controls the amount of strain in the reinforcement which for granular fills is limited to considerably less than the rupture strain of the reinforcement. Therefore even at a limit state, overstress of the geosynthetic reinforcement would cause visible, time-dependent strain in the wall system rather than sudden collapse.
- The long-term properties of geosynthetics, based on limited data, are significantly improved when confined in soil. Confinement is presently not considered in developing nominal long-term strength.
- Measurements of stress in MSE walls reinforced with geosynthetics have consistently indicated lower stress levels than used for design as developed in Chapter 4.

Note that T_{al} is used for RSS structures design with limit equilibrium analysis and computation of a factor of safety against instability.

3.5.2.g Preliminary Design Reduction Factor, RF For preliminary design of permanent structures or for applications defined by the user as not having severe consequences should poor performance or failure occur, the nominal long-term tensile strength T_{al} , may be evaluated without product specific data, as:

$$T_{al} = \frac{T_{ult}}{RF} = \frac{T_{ult}}{7} \quad (3-13)$$

Further, $RF = 7$ should be limited (i.e., do not use Eq. 3-13 where following requirements are not met) to projects where the project environment meets the following requirements:

- Granular soils (sands, gravels) used in the reinforced volume.
- $4.5 \leq \text{pH} \leq 9$
- Site temperature $< 85^\circ \text{F}$ (30°C)
- Maximum backfill particle size of $\frac{3}{4}$ -inch (19 mm)
- Maximum MSEW height is 35 ft (10 m) and
- Maximum RSS height is 50 ft (15 m)

Site temperature is defined as the temperature which is halfway between the average yearly air temperature and normal daily air temperature for the highest month at the site.

RF = 7 has been established by multiplying lower bound partial reduction factors obtained from currently available test data, for products which meet the minimum requirements in Table 3-13. *It should be noted that the total Reduction Factor may be reduced significantly with appropriate test data. It is not uncommon for products with creep, installation damage and aging data, to develop total Reduction Factors in the range of 3 to 6 or even less with the development of new materials.*

For temporary applications not having severe consequences should poor performance or failure occur, a default value for RF of 3.5 rather than 7 may be considered.

Table 3-13. Minimum Requirements for use of Preliminary Design Reduction Factor for Primary Geosynthetic Reinforcement.

Type	Property	Test Method	Criteria to Allow Use of Default RF
Polypropylene	UV Oxidation Resistance	ASTM D4355	Min. 70% strength retained after 500 hrs. in weatherometer
Polyethylene	UV Oxidation Resistance	ASTM D4355	Min. 70% strength retained after 500 hrs. in weatherometer
Polyester	Hydrolysis Resistance	Inherent Viscosity Method (ASTM D4603) with Correlation or Determine Directly Using Gel Permeation Chromatography	Min. Number (Mn) Molecular Weight of 25,000
Polyester	Hydrolysis Resistance	GRI GG7	Max. Carboxyl End Group Number of 30
All Polymers	Survivability	Weight per Unit Area, ASTM D5261	Min. 8 oz/yd ² (270 g/m ²)
All Polymers	% Post Consumer Recycled Material by Weight	Certification of Material used	Maximum 0%

3.5.2.h Serviceability Limit State

Serviceability limit state deflection requirements for geosynthetic reinforcements are met through the use of low stress levels resulting from reduction factors combined with the inherent constraining effects of granular soils. With regard to strain limits on the reinforcement, methods for estimating of strain vary widely with no present consensus on an appropriate analytical method capable of modeling strains in the structure. Measurements

from instrumented field structures have consistently measured much lower strain levels in the reinforcement (typically less than 1 percent) than predicted by most current analytical methods. **Therefore, until an appropriate method of determination is agreed upon, it is recommended that strain limit requirements not be imposed on the reinforcement.**

3.6 FACING MATERIALS

The material aspects of the various facings used with MSE walls structures are discussed below, by facing type. Typical dimensions, manufacturing process and controls, details, durability, and associated materials are discussed. Aesthetics were discussed in Chapter 2. Tolerances of precast panels to settlement were presented in Section 2.8.3. Design aspects of the more commonly used facings are addressed in Section 4.4.8. Specifications are addressed in Chapter 10.

3.6.1 Precast Concrete Panels

3.6.1.a Segmental Panels

Segmental, precast concrete panels are commonly square or rectangular in shape with typical dimensions of 5 to 8-in. (125 to 200 mm) thick and 5-foot (1.5-m) high and a front face width of 5 or 10-ft (1.5 or 3-m). Panels with cruciform, diamond, and hexagonal face geometry are also used. The panels are typically cast with the exposed face down, so they may have a smooth or a form-liner finish. Panels may also be prepared with an exposed aggregate finish. The edges of adjacent panels are cast with a butt, shiplap, or tongue-and-groove joint.

Agencies should check the raw materials, mix design, and precasting operation as they do for other precast, structural items. Generally, agencies have reviewed and approved these items for a particular precaster. Panels are usually produced by a local precaster for, and with forms provided by, the wall vendor. Form dimensions, concrete steel reinforcement placement, and connection hardware placement should be examined for conformance to the vendor's quality control and tolerances. The units must be fully supported until the concrete reaches a minimum compressive strength of 1,000 psi (6.9 MPa). The units may be shipped after reaching a minimum compressive strength of 3,400 psi (23.4 MPa). At the option of the contractor, the units may be installed after the concrete reaches a minimum compressive strength of 3,400 psi (23.4 MPa). The concrete must have a minimum 4,000 psi (27.6 MPa) compressive strength at 28 days. Temperature and tensile steel reinforcement should be designed in accordance with Section 5 of AASHTO LRFD Specifications for Highway Bridges (2007).

Metal connection hardware that is cast into the panel and extends out the back face of the panel for attachment to the soil reinforcement should not be placed in direct contact with the concrete steel reinforcement. This type of placement could accelerate corrosion of metal soil reinforcement. Direct contact is permissible if both have the same protection (e.g., galvanized).

Bearing pads are placed on all horizontal (and diagonal, if applicable) joints of adjacent segmental precast panels as they are erected. Two pads are usually used on 5-foot (1.5-m) wide panels and at least three bearing pads with 10-foot (3-m) wide panels. A minimum of two bearing pads are used per horizontal panel joint. The bearing pads are used to prevent or minimize point loadings or stress concentrations between adjacent panels, and to accommodate small vertical deformation of the panels as the wall height increases and the reinforced wall fill compresses.

Bearing pads shall meet or exceed the following material requirements:

- Preformed EPDM (Ethylene Propylene Diene Monomer) rubber pads conforming to ASTM D2000 Grade 2, Type A, Class A with a Durometer Hardness of 60 ± 5 .
- Preformed HDPE (High Density Polyethylene) pads with a minimum density of 0.946 grams per cubic centimeter in accordance with ASTM D 1505.

The stiffness (axial and lateral), size, and number of bearing pads must be determined such that the final joint opening is not less than the required joint width after compression (e.g., $\frac{1}{2}$ in.) unless otherwise shown on the plans. The MSE wall designer must submit substantiating calculations verifying the stiffness (axial and lateral), size, and number of bearing pads assuming, as a minimum, a vertical loading at a given joint equal to 2 times the weight of facing panels directly above that level. As part of the substantiating calculations, the MSE wall designer must submit results of certified laboratory tests in the form of vertical load-vertical strain and vertical load-lateral strain curves for the specific bearing pads proposed by the MSE wall designer. The vertical load-vertical strain curve should extend beyond the first yield point of the proposed bearing pad.

3.6.1.b Full-Height Panels

Typical dimensions of full-height panels are 6 to 8-in. (150 to 200-mm) thick and 8 or 10-ft (2.4 to 3-m) wide. Single, full-height panel walls have been constructed to a height of approximately 32 ft (10 m). Full-height panels are externally braced until the reinforced soil reaches $\frac{2}{3}$ to full height of the wall.

Full-height panels do not provide the same ability to adjust face panel alignment and rotation during construction, as do segmental panels. Nor are bearing pads used to accommodate elastic settlement of the reinforced fill so the connection detailing and strength must accommodate this deformation. Therefore, if the full-height panels will be used, Agencies should specify experience requirements for the wall vendor, wall designer (if different than the wall vendor), and the wall contractor. Additionally, the maximum height should be limited to about 32 feet (10 m), or less.

Agency controls are the same as for segmental, with the exception that taller, full-height panels have multiple heights of pick-up point hardware cast into the panel. Handling of the panels for shipping and erection should be monitored to ensure panels are not cracked by these operations.

No bearing pads are used with full-height panels. Therefore, high quality reinforced fill should always be used with full-height panel walls. Individual wall systems should address how the reinforcement connection is designed to tolerate elastic fill settlement.

3.6.2 Modular Block Wall Units

Modular block wall (MBW) MSE face units have typical dimensions of 4 to 15-in. (100 to 375-mm) high and 8 to 18-in. (200 to 450-mm) in exposed face length, and 8 to 24-in. (200 to 600-mm) in depth (perpendicular to wall face). MBW units are produced in a masonry manufacturing process. Therefore, the concrete is dry-cast, and unlike wet-cast panels cannot be air entrained or reinforced with steel. These units are also known as “segmental retaining wall” units.

There are a wide variety of commercially available MBW units, as noted in Section 2.4.3. These units are normally produced near the project site by a licensed manufacturer. Quality control requirements and quality assurance vary by licensor and licensee. Therefore, Agencies should control the raw materials, mix design, and casting operation as they do for wet-cast concrete, structural items. Form or cast units should be examined for dimensional tolerances. Many of these units have the face sheared off after casting to create a roughened, rock-like texture for aesthetic reasons.

Dry-cast concrete MBW units are susceptible to freeze-thaw degradation with exposure to deicing salts and cold temperatures. This is a concern in northern tier states that use deicing salts. Some vendors have developed mix designs, with additive(s), and manufacturing processes that result in units that are very durable and resistant to freeze-thaw degradation.

The current specifications in Chapter 10 have been developed to address this issue and clarify requirements depending on the susceptibility to freeze-thaw conditions and salt exposure.

Based on good performance experience by several agencies, ASTM C1372, Standard Specification for Segmental Retaining Wall Units should be used as a model, except that the compressive strength for units should be increased to 4,000 psi (28 MPa) to increase durability, maximum water absorption be limited to 5 percent, requirements for freeze-thaw testing modified, and tolerance limits expanded.

Note that more stringent durability requirements are being used by the Minnesota Department of Transportation (Mn/DOT) based upon their experience, research, climatic conditions and de-icing salt usage. The Mn/DOT criteria (2008) state that wall and cap units shall conform to ASTM C1372, except for the items in Table 3-14.

Several research projects investigating the freeze-thaw durability and degradation of MBW units have been performed. Reports are available from FHWA (Chan et al., 2007) and the University of Minnesota (Embacher et al., 2001a,b).

Freeze-thaw resistance of MBW units is tested following ASTM C1262. These tests generally take more than 3 months to perform. Therefore, the testing is not suited for approval of materials on an individual project basis. The testing is better suited to an agency evaluating and placing MBW units on an approved products list.

MBW units are erected using a running bond configuration. Full-height cores are filled with aggregate during erection units are normally dry-stacked (i.e. without mortar), and erected using a running bond configuration. Vertically adjacent units may be connected with shear pins, lips, or keys.

Geogrid soil reinforcement is typically used with MBW units, though some systems use geotextile and some use steel mat soil reinforcement. The soil reinforcement is connected to the MBW units via a frictional, mechanical, or combination mechanical and frictional-type connection. Bearing pads between vertically adjacent units are not used with MBW units. Therefore, the connection detailing and strength, and the soil placement and compaction must accommodate deformation caused by elastic compression of the reinforced fill. On certain systems, geosynthetic soil reinforcement sandwiched between vertically adjacent units provides some cushioning to distribute bearing loads between blocks.

Table 3-14. Additional MBW Cold Weather Requirements Recommended by Mn/DOT (2008).

Item	Test Standard	Requirement
Compressive strength	ASTM C140, except that Section 6.2.4 shall be deleted and replaced with: “The specimens shall be coupons cut from a finished side or back shell of each unit and sawn to remove any face shell projections. The coupon size shall have a height to thickness ratio of 2 to 1 before capping and a length to thickness ratio of 4 to 1. The coupon shall be cut from the unit such that the coupon height dimension is in the same direction as the unit height dimension. Compressive testing of full size units will not be permitted. The compressive strength of the coupon shall be assumed to represent the net area compressive strength of the whole unit.”	5,500 psi (38 MPa) min. 5,800 psi (40 MPa) min. Average for 3 units
Freeze-thaw durability of wall units	The freeze/thaw durability of wall units tested in accordance with ASTM C1262 in a 3% saline solution shall be the minimum of the following:	(1) the mean weight loss of five test specimens at the conclusion of 90 cycles shall not exceed 1% of its initial weight; (2) the mean weight loss of the 4 lowest out of 5 test specimens at the conclusion of 100 cycles shall not exceed 1.5% of its initial weight. Test results shall be recorded and reported in 10 cycle intervals showing the weight of all specimens and not just the mean value.
Freeze-thaw durability of cap units	The freeze/thaw durability of cap units tested in accordance with ASTM C1262 in a 3% saline solution shall be the minimum of the following:	(1) the mean weight loss of five test specimens at the conclusion of 40 cycles shall not exceed 1% of its initial weight; (2) the mean weight loss of the 4 lowest out of 5 test specimens at the conclusion of 50 cycles shall not exceed 1.5% of its initial weight. Test results shall be recorded and reported in 10 cycle intervals showing the weight of all specimens and not just the mean value.
Cap unit	—	Top surface sloped at 1 inch fall per 10 inch run (1 mm fall per 10 mm run) front to back or crowned at the center.
Surface sealer	Contact Mn/DOT Concrete Engineering Unit, or www.mrr.dot.state.mn.us/pavement/concrete_products.asp , for requirements.	All segmental masonry retaining walls shall have their surfaces sealed. Apply surface sealer to the top, exposed front face, and backside of the upper three courses of all walls.

Therefore, it is recommended that agencies specify wall height experience requirements for the wall vendor, wall designer (if different than the wall vendor), and the wall contractor when MBW unit faced walls are to be used. Additionally, it is recommended that the maximum height typically be limited to about 32 feet (10 m), or less, unless setbacks are used to separate wall facing loads. Taller walls without setbacks require that bearing between units and possible stress concentrations due to geometric variations along the length of the wall be specifically addressed in the design and detailing. Typically, this can be accomplished with horizontal bearing pads or other compression members in the lower portion of the wall and/or vertical joints to separate geometric variations.

The use of polyester geogrid or geotextile soil reinforcements connected to the dry-cast MBW concrete units are discussed in Section 3.5.2.e. Recommendations for design as addressed in Section 3.5.3.e3, Durability Reduction Factor, RF_D , at the Wall Face Unit.

3.6.3 Welded Wire Mesh Facing

Welded wire mesh (WWM) is a popular facing for temporary walls and slopes, and is used in permanent walls and slopes. In permanent walls and slopes, the WWM may be the primary face soil retention element. For these cases, galvanized steel is used. The reinforcements in temporary structures should be galvanized if contact between reinforcements of the temporary structure and of a permanent (galvanized) structure is possible. In some permanent, geosynthetic-reinforced slopes and walls, the WWM is used as a forming device that is left in-place. The geosynthetic is the primary face soil retention element, and for these cases, plain (a.k.a, black) steel is typically used. A temporary WWM wall with a geotextile for retention at the face is shown in Figure 2-3.

Steel facings should be galvanized consistent with the use of galvanized reinforcements. Hot dip galvanizing of at least 2 oz/ft^2 should protect the steel in atmospheric conditions for a period between 20 and 50 years (AGA, 2004). Forty to 50 years are expected in rural and suburban environments, 25 to 30 years in coastal areas, and approximately 20 years if located in proximity to industrial areas where the atmosphere may be acidic. A typical corrosion rate for temporary, non-galvanized steel facing is 1.0 mil/yr ($25 \text{ }\mu\text{m/yr}$). Substantially higher rates should be used if the wall face will be vegetated, where road salts are used, if atmospheric conditions are corrosive such as marine environments or when air quality may be compromised by nearby industrial activity. Corrosion potential can be reduced by using open graded stone in the facing. Note that a corrosion rate of $28 \text{ }\mu\text{m/yr}$ should be applied to plain steel soil reinforcements, if the reinforced fill is not corrosive or only mildly aggressive, for temporary walls.

Hardware cloth that is sometimes used with welded wire facings to contain fill material may be vulnerable to corrosion (if steel) or degradation from UV radiation (if geosynthetic). Designers should assume that the hardware cloth will degrade over time, in permanent walls, and that the WWM will have to retain the wall fill adjacent to the face or maintenance (i.e., repair, replace) of the hardware cloth

For permanent walls, vertical and horizontal spacing of metallic reinforcements for flexible face (welded wire or similar) wall systems should not exceed 18 inches. The stiffness of the facing and spacing of reinforcements must be such that the maximum local horizontal deformation between soil reinforcement layers is limited to less than 1 to 2 in. as specified by the agency. The maximum local horizontal deformation between soil reinforcement layers should also be limited to less than 1 to 2 in. for temporary walls, i.e., walls with up to 36 months service life. This recommendation is particularly important if the temporary wall will be incorporated into a permanent feature, e.g., buried within an embankment fill.

The look of galvanized WWM face may not be desired on some projects due to aesthetic requirements. On some projects, staining of galvanized WWM has been used to achieve desired aesthetics.

3.6.4 Geosynthetic Wrap-Around Facing

Geosynthetic facing elements should not be left exposed to sunlight (specifically ultraviolet radiation) for permanent walls. If geosynthetic facing elements must be left exposed to sunlight, for permanent or temporary structures, the geosynthetic must be stabilized to be resistant to ultraviolet radiation. Furthermore, product specific test data should be provided which can be extrapolated to the intended design life and which proves that the product will be capable of performing as intended in an exposed environment. Vegetative covers provide some protection from UV and in many cases, a healthy vegetative cover can prevent exposure altogether. Alternately, a protective facing must be constructed in addition (e.g., concrete, shotcrete, etc.). A temporary wrap-around wall is shown in Figure 2-3.

3.6.5 Other Facings

Other facings being used on permanent walls, and sometimes on slopes, include: large, up to 3-ft (0.9-m) high and 3 to 10-ft (0.9 to 3-m) in width, wet cast concrete units, gabions, and geocells.

The large wet cast units are typically stacked, similar to MBW units. Generally, geosynthetic soil reinforcements are used with these units. The reinforcement is usually connected to the

facing by friction, i.e., sandwiched between vertically adjacent units, as shown in Figure 3-7. Attachments may also be cast into the units and mechanical connection used, as shown in Figure 3-8.

Rock filled gabions are another large face unit used with MSE walls. One system uses woven-wire soil reinforcement that is integral with the gabion face, so no connection is required. Other systems connect reinforcement to the facing by friction by sandwiching the reinforcement between vertically adjacent units. Connecting the reinforcement by mechanically clipping it to the back of a gabion should be avoided. Most gabions are 3 ft by 3 ft (0.9 by 0.9 m), thus vertical reinforcement exceeds the 32 in. (0.8 m) recommended maximum spacing. This greater spacing may be offset by the size/mass of the facing. Although 36-in. reinforcement spacing has been used successfully on many projects, it is not in agreement with the 32-in. limit to ensure a coherent MSE mass. The Owner should exercise caution in the evaluation of the maximum reinforcement spacing when specific loading conditions, unusual geometries, or soft foundation exist. The Owner and/or wall designer should consider use of secondary reinforcement layers placed in at the center of the unit heights to reduce reinforcement vertical spacing.

Geocells are used to face reinforced soil walls and slopes. Eight-inch (200-mm) high geocells and nominally about 3 ft (0.9 m) wide are typically used. Connection to the soil reinforcement is by friction, i.e., sandwiched between vertically adjacent mats of geocells. The lifts of geocells may be offset and the outer cells filled with topsoil and vegetated, as shown in Figure 3-9.



Figure 3-7. Large, wet-cast concrete face unit with reinforcement placed between units.



Figure 3-8. Large, wet-cast concrete face unit with embedded reinforcement connectors.



Figure 3-9. Geocell face unit with vegetation.

3.6.6 Two-Stage Facings

Two-stage MSE wall construction is used to construct walls on foundations that will undergo significant settlement. The first stage is construction of an MSE wall with a flexible facing (i.e., WWM or geosynthetic wrap). Connectors or form anchors are embedded in the first stage construction. The foundation soils are allowed to settle under the load of the first stage, with or without an additional surcharge load. The second stage consists of facing the first stage with cast-in-place or precast concrete panels. Either full height or segmental precast panels are used and are mechanically connected to the first-stage reinforced soil mass. Connection mechanisms and details may be proprietary to the wall vendor. For cast in place facings, the design of the connection mechanism must consider fluid pressure that develops during pouring of the concrete, which may require staging to avoid connection overstressing.

Precast material control is discussed in Section 3.6.1. Design issues include; 1) estimation of settlement and establishing tolerance limits for the first-stage wall construction, 2) estimating additional long term settlement after construction of the second stage including additional loading from the facing system, and 3) evaluating the long-term durability of the connection hardware between the concrete and MSE mass with consideration for long term differential settlement. Corrosion needs to be addressed for steel connectors and durability for any geosynthetic connectors.

CHAPTER 4

DESIGN OF MSE WALLS

This chapter details design guidelines common to all MSE wall structures. It is limited to MSE walls having a near-vertical face, and uniform length of soil reinforcements. MSE wall design details are addressed in Chapter 5. Design guidelines for complex structures, or structures with unusual features are covered in Chapter 6. Detailed example calculations for both routine and complex structures are presented in Appendix E of this reference manual.

This chapter is organized sequentially as follows:

- Overview of design methods.
 - LRFD
 - Other methods
- Loads and load combinations.
 - LRFD design of MSE walls
- MSE wall design guidelines (step-by-step)
 - Sizing for external stability
 - Sizing for internal stability
- Temporary walls
- Design checklist
- Computer aided design
- Standard MSE wall designs

4.1 DESIGN METHODOLOGY AND ANALYSIS METHODS

4.1.1 Load and Resistance Factor Design (LRFD) Platform

Traditionally, the MSE wall design has been performed using the Allowable Stress Design (ASD) methodology. The LRFD methodology is the latest advancement in transportation structures design practice. The LRFD method in various forms is now being applied throughout the world. For example, EuroCode uses the limit state design (LSD) methodology, which is very similar to the LRFD methodology. Regardless of the design methodology, the core analytical methods for MSE walls such as external and internal stability evaluation remain unchanged. The assumption of a coherent gravity mass for external stability, the shape of the internal failure planes, and treatment of reinforcements as discrete elements remains unchanged. The primary change is in the way the loads and resistances are compared and how uncertainty is incorporated into the design process.

Specific to the topic of MSE walls the following points regarding LRFD methodology should be noted to prevent any confusion in application of the various theories and equations presented in this chapter:

- The symbol ϕ (phi) is used for both the soil friction angle and the LRFD resistance factor.
- The symbol γ (gamma) is used for both soil unit weight and the LRFD load factor.
- Load and resistance factors for MSE walls are currently calibrated by fitting to ASD results. Therefore, designs using LRFD procedure should not significantly vary from past, expected ASD designs.
- For most MSE wall system designs, strength limit states generally control the member sizes. Service limit states may control aspects such as joint width openings and construction sequence based on the anticipated deformations. Extreme event limit states may affect both the member sizes as well as deformations.

4.1.2 Analysis Methods

As noted earlier, the core analysis methods for MSE walls are unchanged relative to ASD practice. AASHTO (2002), which is based on the ASD method, recommended the use of the *Simplified Method* (a.k.a., *Simplified Coherent Gravity Method*) provided in the previous version of this manual. {Note: The AASHTO (2002) and FHWA (Elias et al., 2001) ASD references will not be updated by AASHTO or FHWA, respectively.}

It is acknowledged that other analytical methods are also available in the literature as follows:

- Allowable Stress Design (ASD) Procedure and the Simplified Method (AASHTO, 2002 and FHWA NHI-00-043 {Elias et al., 2001})
- Coherent Gravity Method Analysis Model
- National Concrete Masonry Association (NCMA) Procedure (NCMA, 2009)
- Geosynthetic Reinforced Soil (GRS) Method (Wu et al., 2006)
- K-Stiffness Method (Allen and Bathurst, 2003; Allen et al., 2003; Allen et al., 2004; WSDOT, 2006; and Bathurst et al., 2008a)

The LRFD methodology permits consideration of any of the above methods as long as appropriate calibrations are performed for resistance factors using acceptable quality statistical data. This chapter concentrates on application of the Simplified Method which is recommended due to its applicability to a variety of soil reinforcement types (in contrast to the limited applicability of the alternative methods to specific type of reinforcements, e.g., GRS method is strictly applicable to geosynthetic reinforcements), and it is a methodology that has been successfully used in practice for many years. Brief descriptions of these other analytical methods are included in Appendix F.

4.2 LOADS AND LOAD COMBINATIONS

A complete list of various loads, load factors and load combinations that need to be considered in design of bridge structures and associated transportation structures such as retaining walls and culverts is presented in Section 3 of AASHTO (2007). Many load types are commonplace to design of bridge structures and not applicable to retaining walls as noted in Section 11 of AASHTO (2007). With respect to MSE wall structures, only a few of the loads and load combinations are applicable on a routine basis. The applicable loads for most MSE wall applications are summarized below followed by a summary of applicable load combinations in Tables 4-1 and 4-2. Complete load combination and load factor tables (per AASHTO, 2007) are contained in Appendix A.

Applicable Loads

Permanent Loads

- EH = Horizontal earth loads
- ES = Earth surcharge load
- EV = Vertical pressure from dead load of earth fill

Transient Loads

- CT = Vehicular collision force
- EQ = Earthquake load
- LL = Vehicular live load
- LS = Live load surcharge

An example of an ES load on an MSE wall is the pressure from a spread footing above the reinforced mass. An example EV load is a sloping fill above the top of an MSE wall. Further distinction is made under the external and the internal design steps that follow.

Table 4-1. Typical MSE Wall Load Combinations and Load Factors
(after Table 3.4.1-1, AASHTO {2007}).

Load Combination Limit State	EH ES EV	LL LS	Use One of These at a Time	
			EQ	CT
STRENGTH I	γ_p	1.75	–	–
EXTREME EVENT I	γ_p	γ_{EQ}	1.00	–
EXTREME EVENT II	γ_p	0.50	–	1.00
SERVICE I	1.00	1.00	–	–

Notes:
 γ_p = load factor for permanent loading. May subscript as γ_{p-EV} , γ_{p-EH} , etc.
 γ_{EQ} = load factor for live load applied simultaneously with seismic loads

Table 4-2. Typical MSE Wall Load Factors for Permanent Loads, γ_p
(after Table 3.4.1-2, AASHTO {2007}).

Type of Load	Load Factor	
	Maximum	Minimum
<i>DC</i> : Component and Attachments	1.25	0.90
<i>EH</i> : Horizontal Earth Pressure <ul style="list-style-type: none"> • Active 	1.50	0.90
<i>EV</i> : Vertical Earth Pressure <ul style="list-style-type: none"> • Overall Stability • Retaining Walls and Abutments 	1.00 1.35	N/A 1.00
<i>ES</i> : Earth Surcharge	1.50	0.75

Note: May subscript as γ_{EV-MIN} , γ_{EV-MAX} , γ_{EH-MIN} , γ_{EH-MAX} , etc.

Maximum and Minimum Load Factors

Two load factors, a maximum and a minimum, are listed in Table 4-2. It is important to understand the application of these load factors in context of MSE walls. Article 3.4.1 AASHTO (2007) states that: *“The factors shall be selected to produce the total extreme factored force effect. For each load combination, both positive and negative extremes shall be investigated. In load combinations where one force effect decreases another effect, the minimum value shall be applied to the load reducing the force effect. For permanent force effects, the load factor that produces the more critical combination shall be selected. . . . Where the permanent load increases the stability or load-carrying capacity of a component or bridge, the minimum value of the load factor for that permanent load shall also be investigated.”*

In general, AASHTO's guidance can be applied by using minimum load factors if permanent loads increase stability and use maximum load factors if permanent loads reduce stability. For simple walls, e.g., level backfill with or without surcharges due to traffic, or sloping backfill, the load factor (minimum or maximum) to use for a particular stability check may be readily identifiable. The load factors to use for such simple walls for external stability calculations are illustrated in Figure 4-1. The maximum EV load factor should be used for internal stability calculations.

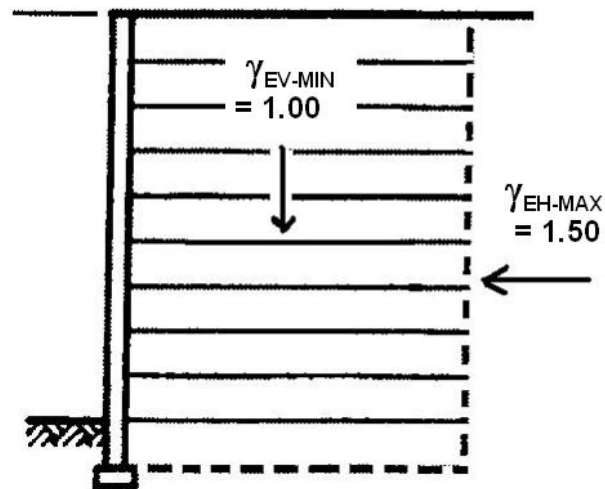

a. Typical load factors for sliding stability and eccentricity check.

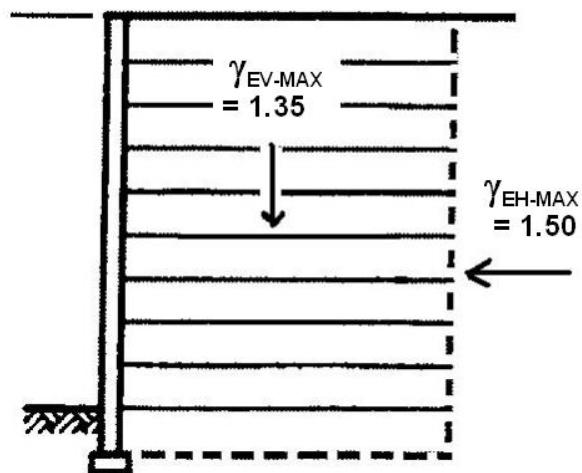

b. Typical load factors for bearing calculations.

Figure 4-1. External stability load factors for simple walls.

The basic concept of load combinations using maximum and minimum load factors is applicable to more complex MSE wall configurations, such as those that may be experienced at bridge abutments or walls with complex geometries (see Chapter 6). Therefore, different combinations of load factors will need to be investigated to determine the total extreme factored (critical) force effect for each applicable limit state.

While the positive and negative extremes are the two bounds, an intermediate combination of maximum and minimum load factors can create the critical force effect for design purposes. This is particularly applicable to retaining walls, wherein various components within a wall system may separately experience maximum or minimum loads. For example, in MSE walls, while the reinforced soil mass may be constructed such that it results in a maximum load, it is conceivable that the construction of retained fill may be at a minimum load level. Therefore, a critical combination of loads needs to be evaluated based on applicable maximum and minimum load factors. The detailed design examples complex MSE wall configurations in Appendix E use the concept of using minimum and maximum load factors.

4.3 DESIGN OF MSE WALLS USING LRFD METHODOLOGY

The procedure for design of MSE walls using LRFD methodology is very similar to that using ASD methodology. In LRFD, the external and internal stability of the MSE wall is evaluated at all appropriate strength limit states and overall stability and lateral/vertical wall movement are evaluated at the service limit state. Extreme event load combinations are used to design and analyze for conditions such as vehicle impact and seismic loading (see Chapter 7 for extreme event design). The specific checks for the strength and service limit states required for MSE wall design are listed below.

Strength Limit States for MSE walls

- External Stability
 - Limiting Eccentricity
 - Sliding
 - Bearing Resistance
- Internal Stability
 - Tensile Resistance of Reinforcement
 - Pullout Resistance of Reinforcement
 - Structural Resistance of Face Elements
 - Structural Resistance of Face Element Connections

Service Limit States for MSE walls

- External Stability
 - Vertical Wall Movements
 - Lateral Wall Movements

Global Stability of MSE walls

- Overall Stability
- Compound Stability

The external stability of an MSE wall is evaluated assuming that the reinforced soil zone acts as a rigid body. This is because, when properly designed, the wall facing and the reinforced soil act as a coherent block with lateral earth pressures acting on the back side of that block.

The internal stability of the reinforced soil zone is dependent on three fundamental characteristics:

- the soil-reinforcement interaction (resistance to pullout and to sliding, for sheet-type reinforcements);
- the tensile resistance of the reinforcement; and
- the durability of the reinforcing material.

Therefore, the internal stability analyses of an MSE wall in LRFD is evaluated by (a) determining the maximum factored load in each reinforcement and (b) comparing this maximum factored load to the factored pullout resistance and to the factored tensile resistance of the reinforcement for all applicable strength, service, and extreme event limit states.

Capacity to Demand Ratio (CDR)

With LRFD, the goal is to have the factored resistance greater than the factored load. The term capacity to demand ratio, CDR, is used to quantify the ratio of the factored resistance to the factored load. This term is useful in identifying critical and controlling limit states.

4.3.1 Design Steps

There are eleven basic design steps for an MSE wall, as listed in Table 4-3. Some of these steps have several sub-steps in the design process. These steps are for walls with simple geometries, as discussed in this chapter. Steps can vary somewhat depending on on type of reinforcement and/or whether or not type of reinforcement is initially defined. Additional steps are required for more complex cases such as true bridge abutments, as discussed in Chapter 6.

Table 4-3. Basic LRFD Design Steps for MSE Walls.

Step 1.	Establish Project Requirements – including all geometry, loading conditions (permanent, transient, seismic, etc.), performance criteria, and construction constraints.
Step 2.	Establish Project Parameters – evaluate existing topography, site subsurface conditions, reinforced wall fill properties, and retained backfill properties.
Step 3.	Estimate Wall Embedment Depth, Design Height(s), and Reinforcement Length
Step 4.	Define nominal loads
Step 5.	Summarize Load Combinations, Load Factors, and Resistance Factors
Step 6.	Evaluate External Stability
	a. Evaluate sliding
	b. Evaluate eccentricity
	c. Evaluate bearing on foundation soil
	d. Settlement analysis (at service limit state)
Step 7.	Evaluate Internal Stability
	a. Select type of soil reinforcement
	b. Define critical failure surface (for selected soil reinforcement type)
	c. Define unfactored loads
	d. Establish vertical layout of soil reinforcements
	e. Calculate factored horizontal stress and maximum tension at each reinforcement level.
	f. Calculate nominal and factored long-term tensile resistance of soil reinforcements
	g. Select grade (strength) of soil reinforcement and/or number of soil reinforcement elements at each level.
	h. Calculate nominal and factored pullout resistance of soil reinforcements, and check established layout
	i. Check connection resistance requirements at facing
	j. Estimate lateral wall movements (at service limit state)
k. Check vertical movement and compression pads	
Step 8.	Design of Facing Elements
Step 9.	Assess Overall Global Stability
Step 10.	Assess Compound Stability
Step 11.	Design Wall Drainage Systems.
	a. Subsurface drainage
	b. Surface drainage

4.4 MSE WALL DESIGN GUIDELINES

4.4.1 Step 1 – Establish Project Requirements

Prior to proceeding with the design, the following parameters must be defined:

- Geometry
 - Wall heights
 - Wall batter
 - Backslope
 - Toe slope
- Loading Conditions
 - Soil surcharges
 - Live (transient) load surcharges
 - Dead (permanent) load surcharges
 - Loads from adjacent structures that may influence the internal or external stability of MSE wall system, e.g., spread footings, deep foundations, etc.
 - Seismic
 - Traffic barrier impact
- Performance Criteria
 - Design code (e.g., AASHTO LRFD)
 - Maximum tolerable differential settlement
 - Maximum tolerable horizontal displacement
 - Design life
 - Construction Constraints

The chosen performance criteria should reflect site conditions and agency or AASHTO code requirements, which are discussed in detail in Chapters 2 and 3 of this manual.

4.4.2 Step 2 – Establish Project Parameters

The following must be defined by the agency (Owner) and/or its designer:

Existing and proposed topography

- Subsurface conditions across the site
 - Engineering properties of foundation soils (γ_f , c'_f , ϕ'_f , c_u)
 - Groundwater conditions
- Reinforced wall fill – engineering properties of the reinforced soil volume (γ_r , ϕ'_r)
- Retained backfill – engineering properties of the retained fill (γ_b , c'_b , ϕ'_b), addressing all possible fills (e.g., in-situ, imported, on-site, etc.). Cohesion in the retained backfill is usually assumed to be equal to zero. See FHWA Earth Retaining Structures reference

manual (Tanyu et al., 2008) for guidance on value of cohesion and calculation of the lateral pressure if a cohesion value is used in design.

Note that AASHTO uses the subscript f for both the foundation and retained backfill soils. In the text of this reference manual, the subscript f is used for foundation soil and subscript b is used for the retained backfill.

The reinforced wall fill should be a select granular material, as detailed in Chapter 3 of this manual and in Article 7.3.6.3 AASHTO LRFD Bridge Construction Specifications (2004). Per Article 11.10.6.2 (AASHTO, 2007) the maximum friction angle of the select granular reinforced fill should be assumed to be 34° , unless the project specific fill is tested for frictional strength by triaxial or direct shear testing methods. A design friction angle greater than 40° should not used, even if the measured friction angle is greater than 40° . Note, that while 34° is a maximum value in absence of testing, some soils such as semi-rounded to round, uniform sands, that meet the specified gradation have a friction angle lower than 34° . In geologic areas where such soils are found (e.g., Florida, Wisconsin, Minnesota, etc.), it is recommended that project specific fill shear strength tests be performed. Similarly, where soils are micaceous, project specific shear strength tests should be performed. Also note, it is assumed that the select granular reinforced fill is noncohesive, i.e., cohesion is assumed equal to zero.

For the foundation soil, Article 11.10.5.3 (AASHTO, 2007) notes that in absence of specific data, a maximum friction angle, ϕ'_f , of 30° may be used. The use of an assumed, non-specific parameter is recommended only for preliminary sizing. As discussed in Chapter 2, a project specific site evaluation, that defines subsurface conditions and properties, is required for design of MSE wall structures.

An assumed friction angle, ϕ'_b , of 30° is often used for the retained (i.e., behind the reinforced zone) backfill. The use of an assumed, non-specific parameter is recommended only for preliminary sizing. As discussed in Chapter 2, a project specific site evaluation, that defines subsurface conditions and properties, is required for the design of MSE wall structures; or the use of a backfill specification that assures that the minimum friction angle is obtained. Most agencies have defined allowable property ranges for the retained fill (may be classified as an *embankment* fill material) and have appropriate friction angle(s) established for design.

4.4.3 Step 3 – Estimate Wall Embedment Depth and Reinforcement Length

The process of sizing the structure begins by determining the required embedment, established under Project Criteria (Section 2.8.3, see Table 2-2), and the final exposed wall height, the combination of which is the full design height, H , for each section or station to be investigated. Use of the full height condition is required for design as this condition usually prevails in bottom-up constructed structures, at least to the end of construction.

A preliminary length of reinforcement is chosen to initiate design. The length should be the greater of $0.7H$ or 8 ft (2.5 m), where H is the design height of the structure. Structures with sloping surcharge fills or other concentrated loads, such as abutments, generally require longer reinforcements for stability, often on the order of $0.8H$ to $1.1H$ (see Table 2-1). This preliminary reinforcement length is checked in the external and the internal stability calculations.

Generally, the reinforcement length should be uniform throughout the entire height of the wall. One exception is special structures with shorter reinforcement lengths at the base of the wall; these are addressed in Chapter 6. Another exception is the use of longer layers of reinforcement at the top of a wall. It is recommended that the upper two layers of soil reinforcement be extended 3 ft (0.9 m) beyond the other layers where post-constructive movements at the reinforced zone and retained backfill have been observed on previous, similar projects or if a seismic loading could lead to tension cracks in the backfill soil immediately behind the reinforcement. The design can be completed assuming uniform lengths, and the extra length added to the top two layers when detailing and specifying.

The 8 ft (2.5 m) minimum is used to accommodate the typical size of fill spreading and compaction equipment used on transportation works. As noted in Commentary C.11.10.2.1 AASHTO (2007), a minimum soil reinforcement length, on the order of 6.0 ft (1.8 m) can be considered for short walls if smaller compaction equipment is used and other wall design requirements are met. But, the minimum of $0.7H$ should be maintained. This shorter minimum length of 6 ft (1.8 m) is generally used only for landscape features (e.g., walls not supporting traffic).

4.4.4 Step 4 – Define Nominal Loads

The primary sources of external loading on an MSE wall are the earth pressure from the retained backfill behind the reinforced zone and any surcharge loadings above the reinforced zone. Thus, the loads for MSE walls may include loads due to horizontal earth pressure (EH), vertical earth pressure (EV), live load surcharge (LS), and earth surcharge (ES). Water

(WA) and seismic (EQ) should also be evaluated if applicable. Stability computations for walls with a near vertical face are made by assuming that the MSE wall acts as a rigid body with earth pressures developed on a vertical pressure plane at the back end of the reinforcements, as shown in Figures 4-2, 4-3, and 4-4. Estimation of earth pressures on MSE walls for three different conditions (i.e., horizontal backslope with traffic surcharge, sloping backslope, and broken backslope) follows.

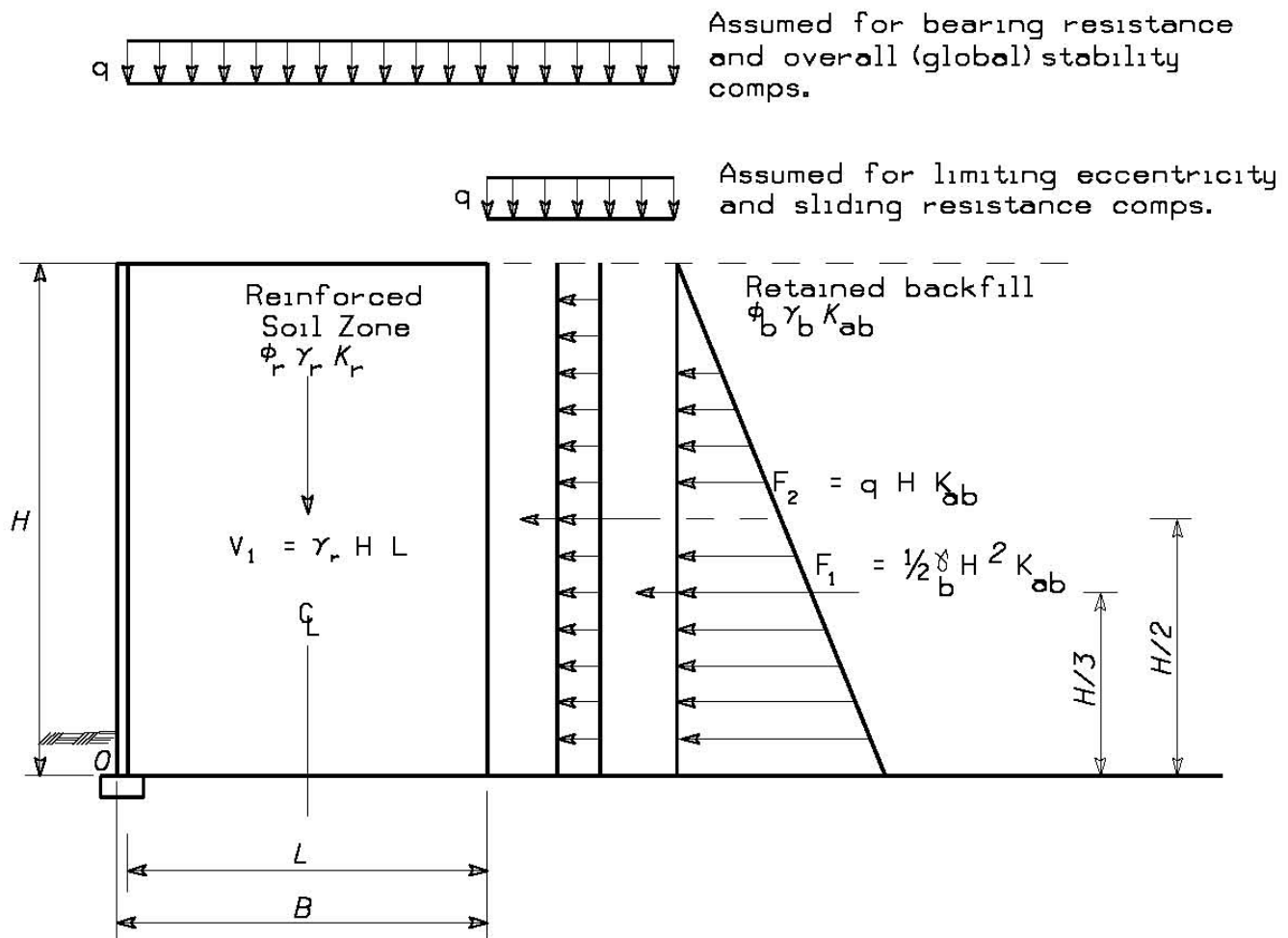

Figure 4-2. External analysis: nominal earth pressures; horizontal backslope with traffic surcharge (after AASHTO, 2007).

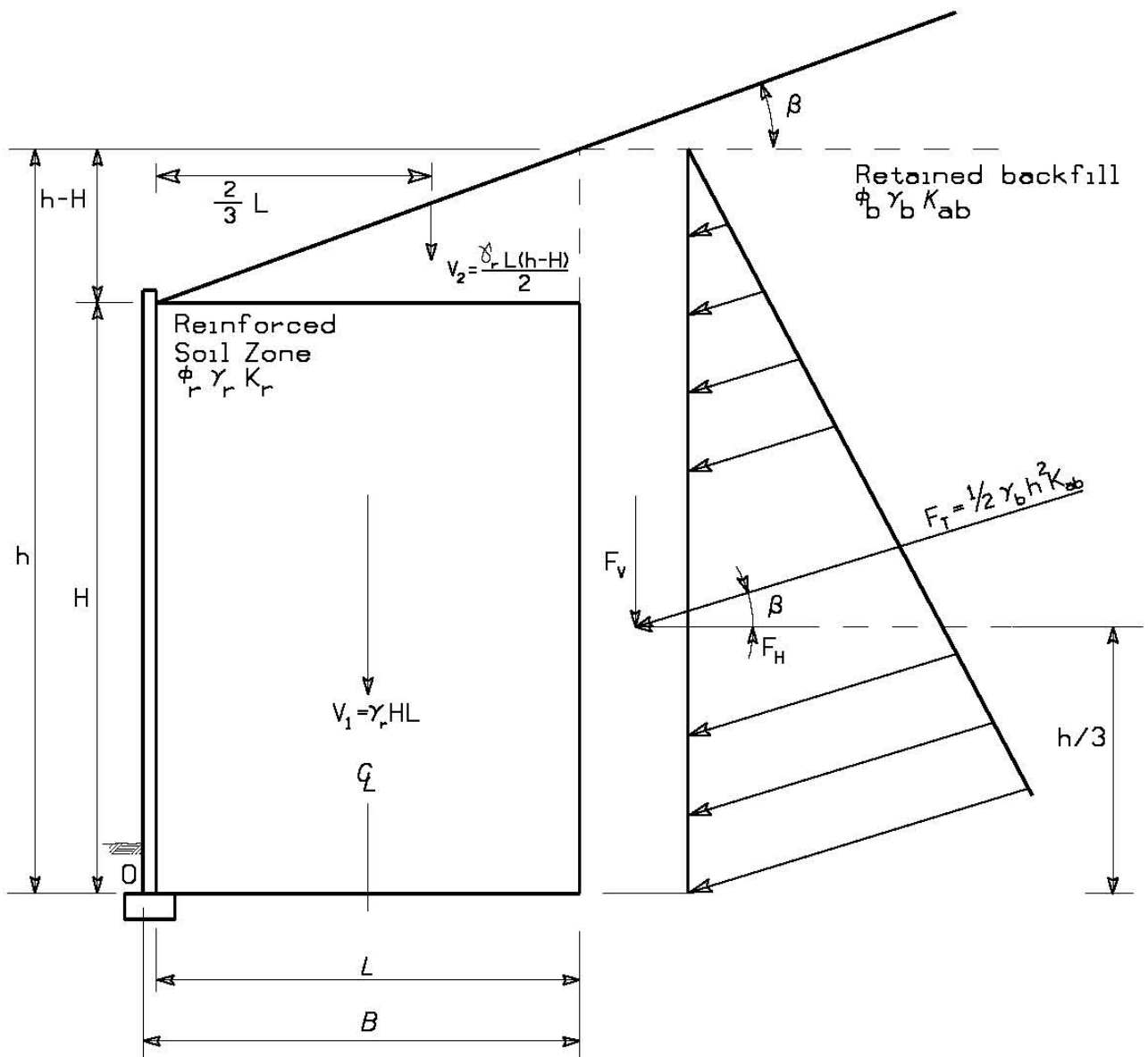

Figure 4-3. External analysis: earth pressure; sloping backfill case (after AASHTO, 2007).

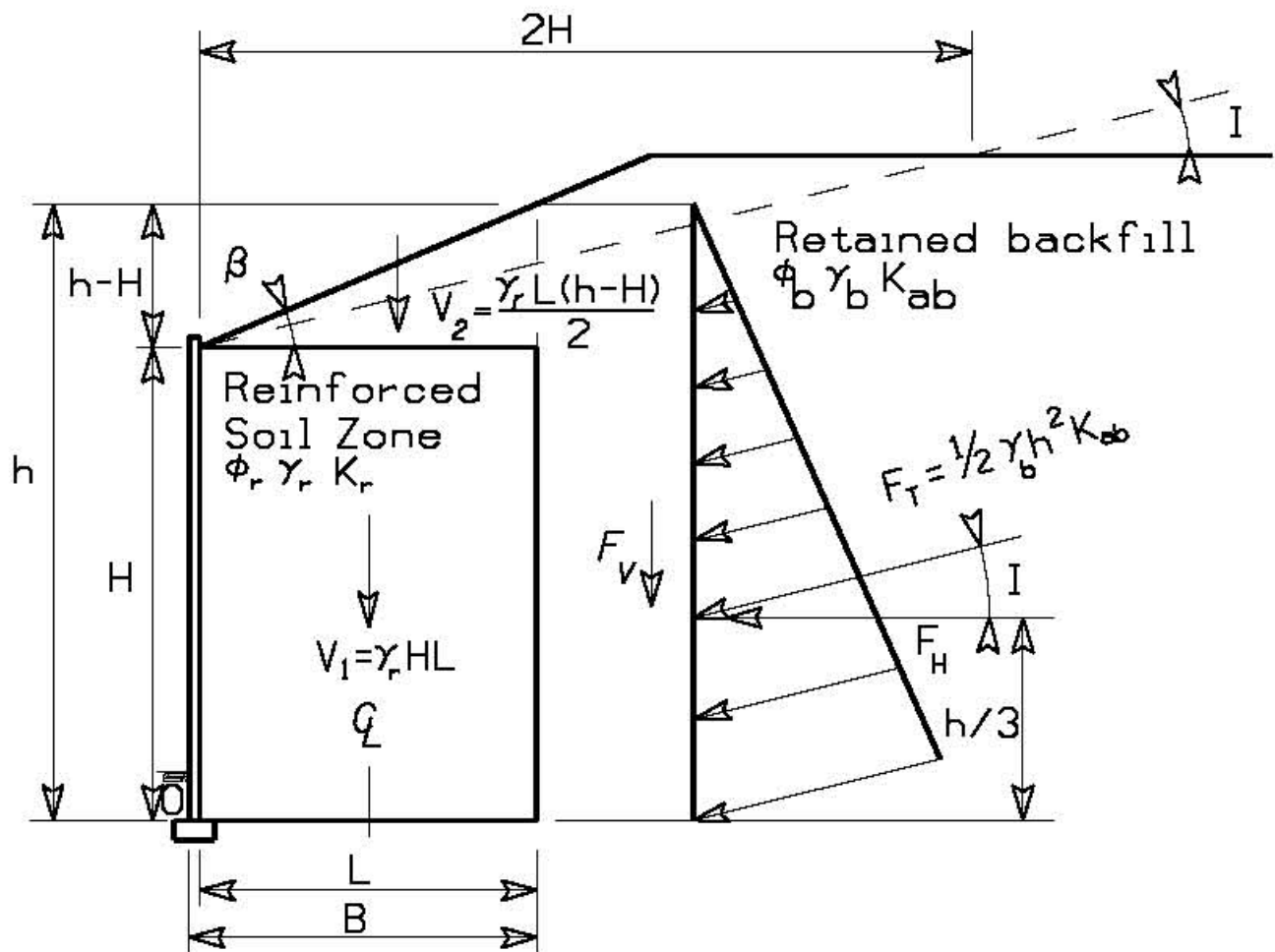

Figure 4-4. External analysis: earth pressure; broken backslope case (after AASHTO, 2007).

Vertical Wall and Horizontal Backslope: The active coefficient of earth pressure is calculated for near vertical walls (defined as walls with a face batter of less than 10 degrees from vertical) and a horizontal backslope from:

$$K_{ab} = \tan^2 \left(45 - \frac{\phi'_b}{2} \right) \quad (4-1)$$

where: ϕ'_b = friction angle of retained backfill.

Vertical Wall and a Surcharge Slope: The active coefficient of earth pressure is calculated for near vertical walls (defined as walls with a face batter of less than 10 degrees from vertical) and a sloping backfill from:

$$K_{ab} = \frac{\sin^2(\theta + \phi'_b)}{\Gamma \sin^2 \theta \sin(\theta - \delta)} \quad (4-2)$$

where:

$$\Gamma = \left[1 + \sqrt{\frac{\sin(\phi'_b + \delta) \sin(\phi'_b - \beta)}{\sin(\theta - \delta) \sin(\theta + \beta)}} \right]^2 \quad (4-3)$$

β = Nominal slope of backfill behind wall (deg)

δ = Angle of friction between retained backfill and reinforced soil, set equal to β (deg)

ϕ'_b = effective friction angle of retained backfill (deg)

θ = 90° for vertical, or near ($< 10^\circ$) vertical, wall (deg)

Note that the earth pressure force, (F_T) in Figure 4-3, is oriented at the same angle as the backslope, β , as it is assumed that $\delta = \beta$.

Vertical Wall with Broken Backslope: The active earth pressure coefficient (K_a) for this condition is computed using Equations 4-2 and 4-3, with the design β angle and the interface angle δ both set equal to I, as defined in Figure 4-4.

Battered Wall with or without Backslope: For an inclined front face and reinforced zone (i.e., batter) equal or greater than 10 degrees from vertical, the coefficient of earth pressure can be calculated using Equations 4-2 and 4-3 where θ is the face inclination from horizontal, and β the surcharge slope angle as shown in Figure 4-5. The wall friction angle δ is assumed to be equal to β .

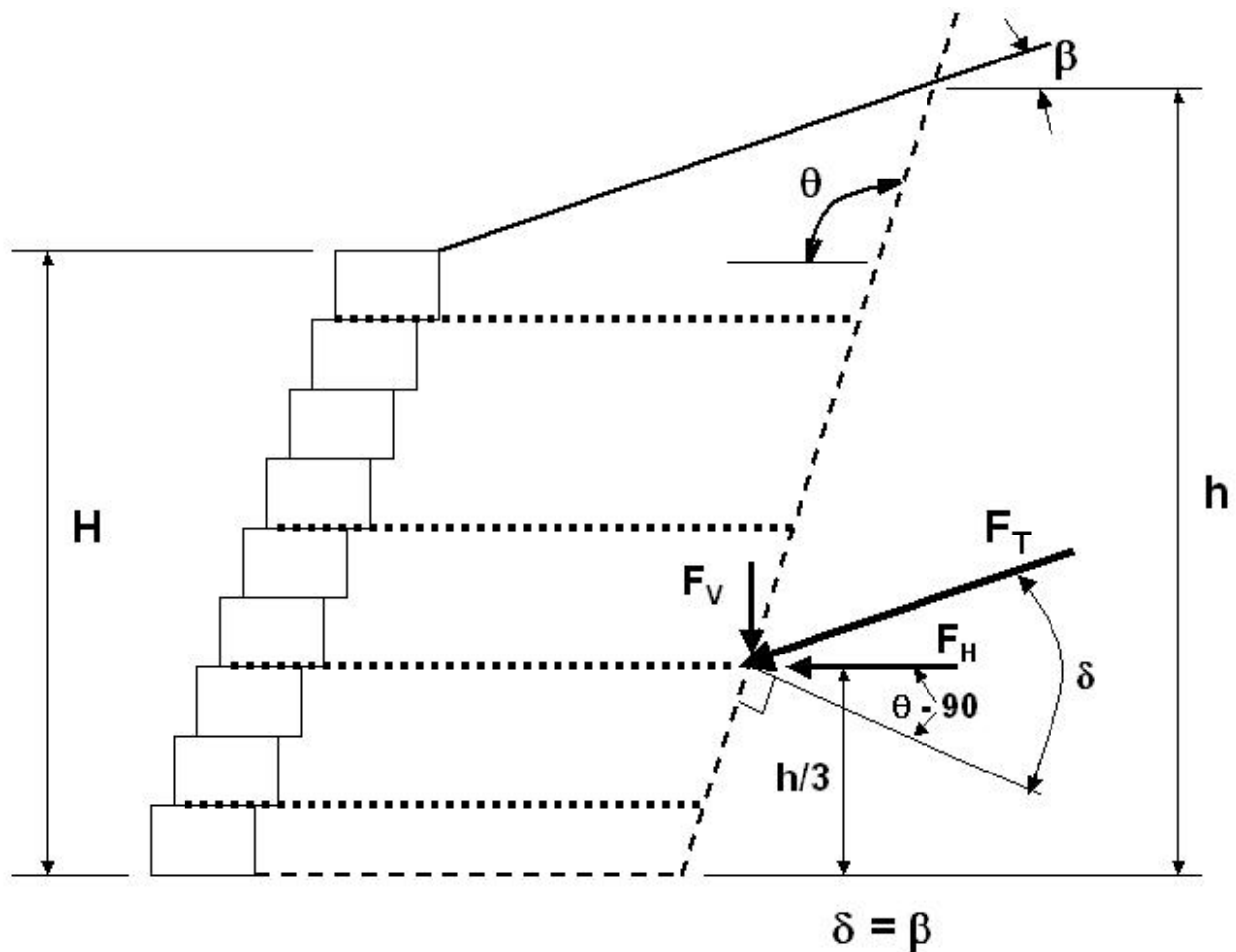

Figure 4-5. Notation for Coulomb active earth pressures used with wall batters, θ , greater than 100° (after AASHTO, 2007).

Traffic Loads

Traffic loads should be treated as uniform surcharge live load of not less than 2.0 ft (0.6 m) of earth (Article 11.10.10.2, AASHTO {2007}). For external stability, traffic load for walls parallel to traffic will have an equivalent height of soil, h_{eq} equal to 2.0 ft. For internal stability, traffic load for walls parallel to traffic will have a h_{eq} , equal to 2.0 ft unless traffic is allowed within 1.0 ft of the back of the wall facing. Commonly the wheel path is more than 1-ft behind the wall backface due to the presence of a traffic barrier and, therefore, a h_{eq} value of 2 ft is applicable.

Equivalent heights of soil, h_{eq} , for uniform surcharge loadings on retaining wall abutments with traffic running perpendicular to the wall may be taken from Table 4-4. Linear

interpolation is used for intermediate wall heights. Typically, the abutment h_{eq} will be acting on the stub abutment that sits on top of the reinforced soil zone (see Figure 4-13). If a structural approach slab is used and is supported on the backwall of the abutment (and not by the soil), the load is directly transmitted to the abutment; in this case $h_{eq} = 0$ is used unless otherwise mandated by an owner.

If the surcharge is for other than highway vehicular loading, the owner should specify or approve different surcharge load.

Table 4-4. Equivalent Height of Soil, h_{eq} , for Traffic Loading on Abutments Perpendicular to Traffic (Table 3.11.6.4-1, AASHTO {2007}).

Abutment Height (ft)	h_{eq} (ft)
5.0	4.0
10.0	3.0
≥ 20.0	2.0

Soil Compaction-Induced Earth Pressures

Compaction stresses are already included in the design model and specified compaction procedures for MSE walls (Article C3.11.2, AASHTO {2007}). Therefore, no additional design considerations are required.

4.4.5 Step 5 – Summarize Load Combinations, Load Factors, and Resistance Factors

Load combinations were discussed in Section 4.2, and typically may include Strength I, Extreme I and/or II, and Service I limits. Note however, that in certain states, the Strength II limit state is more critical than the Strength I limit state because owner prescribed legal loads are greater than those provided in the AASHTO specifications (2007). Maximum permanent loads, minimum permanent loads, and total extremes should be checked for a particular load combination for walls with complex geometry and/or loadings to identify the critical loading. Examination of only the critical loading combination, as described in Section 4.2, is sufficient for simple walls. Load factors typically used for MSE walls are listed in Tables 4-1 and 4-2. Refer to the information in Appendix E or Section 3 of AASHTO (2007) for load factors to use with complex MSE wall configurations and loadings.

Live loads are not used on specific design steps since they contribute to stability. These are identified in subsequent design steps.

Resistance factors for external stability and for internal stability are presented in respective design step discussions that follow. Internal stability resistance factors are listed later in Table 4-7.

4.4.6 Step 6 – Evaluate External Stability

As with classical gravity and semigravity retaining structures, four potential external failure mechanisms are usually considered in sizing MSE walls, as shown in Figure 4-6. They include:

- Sliding on the base
- Limiting eccentricity (formerly known as overturning)
- Bearing resistance
- Overall/global stability (see Step 8)

The resistance factor for external stability analyses of MSE walls are listed in Table 4-5.

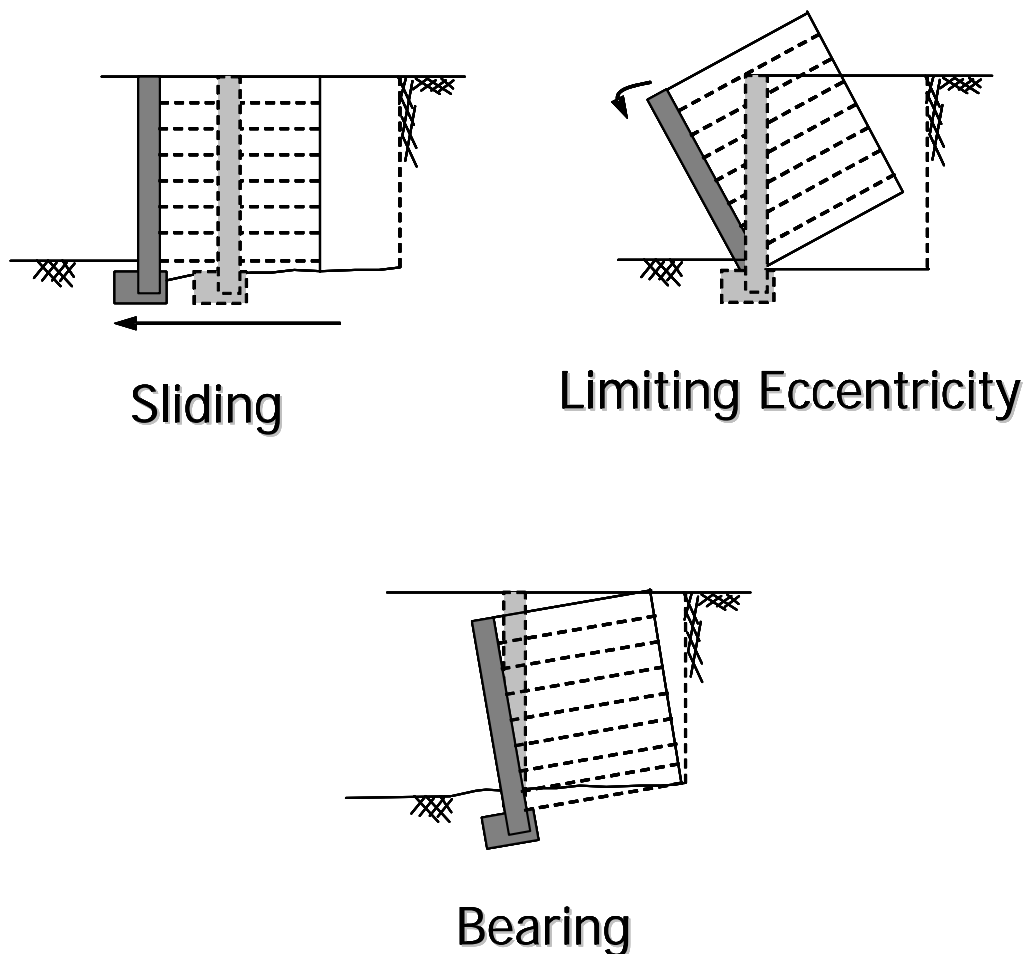

Figure 4-6. Potential external failure mechanisms for a MSE wall.

Table 4-5. External Stability Resistance Factors for MSE Walls
(Table 11.5.6-1, AASHTO {2007}).

Stability Mode	Condition	Resistance Factor
Bearing Resistance		0.65
Sliding		1.0
Overall (global) Stability	Where geotechnical parameters are well defined, and the slope does not support or contain a structural element	0.75
	Where geotechnical parameters are based on limited information, or the slope contains or supports a structural element	0.65

4.4.6.a Evaluate Sliding Stability

Check the preliminary sizing with respect to sliding of the reinforced zone where the resisting force is the lesser of the shear resistance along the base of the wall or of a weak layer near the base of the MSE wall, and the sliding force is the horizontal component of the thrust on the vertical plane at the back of the wall (see Figures 4-2 through 4-4). The live load surcharge is not considered as a stabilizing force when checking sliding, i.e., the sliding stability check only applies the live load above the retained backfill, as shown in Figure 4-2. The driving forces generally include factored horizontal loads due to earth, water, seismic, and surcharges.

Sliding resistance along the base of the wall is evaluated using the same procedures as for spread footings on soil as per Article 10.6.3.4 (AASHTO, 2007). The factored resistance against failure by sliding (R_R) can be estimated by:

$$R_R = \phi_\tau R_\tau \quad (4-4)$$

where:

ϕ_τ = resistance factor for shear resistance between soil and foundation
(equal to 1.0 for sliding of soil-on-soil, see Table 4-5)

R_τ = nominal sliding resistance between reinforced fill and foundation soil

Note that any soil passive resistance at the toe due to embedment is ignored due to the potential for the soil to be removed through natural or manmade processes during its service life (e.g. erosion, utility installation, etc.). Also, passive resistance is usually not available during construction. The shear strength of the facing system is also conservatively neglected.

Calculation steps and equations to compute sliding for two typical cases follow. These equations should be extended to include other loads and geometries, for other cases, such as additional live and dead load surcharge loads.

- 1) Calculate nominal thrust, per unit width, acting on the back of the reinforced zone.

Wall with Horizontal Backslope: (see Figure 4-2)

The retained backfill resultant, F_1 , is:

$$F_1 = \frac{1}{2} K_{ab} \gamma_b H^2 \quad (4-5)$$

For a uniform surcharge, the resultant is:

$$F_2 = K_{ab} q H \quad (4-6)$$

where:

K_{ab} = active earth pressure coefficient for the retained backfill

γ_b = moist unit weight of the retained backfill soil

H = height of the retaining wall

q = uniform live load surcharge = $(\gamma_f)(h_{eq})$

Wall with Sloping Backfill: (see Figure 4-3)

Calculate nominal retained backfill force resultant per unit width, F_T

$$F_T = \frac{1}{2} K_{ab} \gamma_b h^2 \quad (4-7)$$

where:

K_{ab} = active earth pressure coefficient for the sloping backfill, see Eq. 4-2

h = total height of wall, H , and slope at the back of the reinforced zone

= $H + L \tan \beta$

For a broken backslope (see Figure 4-4), $h - H$ should not exceed the height of the upper crest. If the broken backslope height is defined as “ S ”, then $(H + L \tan \beta) \leq (H + S)$; use $(H + S)$ if $(L \tan \beta) > S$.

- 2) Calculate the nominal and the factored horizontal driving forces. For a horizontal backslope and uniform live load surcharge:

$$\sum \mathbf{F} = \mathbf{F}_1 + \mathbf{F}_2 \quad (4-8)$$

$$\mathbf{P}_d = \gamma_{EH} \mathbf{F}_1 + \gamma_{LS} \mathbf{F}_2 \quad (4-9)$$

For a sloping backfill condition:

$$\mathbf{F}_H = \mathbf{F}_T \cos\beta \quad (4-10)$$

$$\mathbf{P}_d = \gamma_{EH} \mathbf{F}_H = \gamma_{EH} \mathbf{F}_T \cos\beta \quad (4-11)$$

Use the maximum EH load factor (= 1.50) in these equations because it creates the maximum driving force effect for the sliding limit state.

- 3) Determine the most critical frictional properties at the base. Choose the minimum soil friction angle, ϕ for three possibilities:
 - i) Sliding along the foundation soil, if its shear strength (based on $c'_f + \tan \phi'_f$ and/or c_u for cohesive soils) is smaller than that of the reinforced fill material shear strength ($\tan \phi'_r$).
 - ii) Sliding along the reinforced fill (ϕ'_r).
 - iii) For sheet type reinforcement, sliding along the weaker of the upper and lower soil-reinforcement interfaces. The soil-reinforcement friction angle ρ , should preferably be measured by means of interface direct shear tests. In absence of testing, it may be taken as $\frac{2}{3} \tan \phi'_r$.
- 4) Calculate the nominal components of resisting force and the factored resisting force per unit length of wall. For a horizontal backslope and uniform live load surcharge, the live load is excluded since it increases sliding stability:

$$\mathbf{R}_r = \gamma_{EV} V_1 \times \mu \quad (4-12)$$

For a sloping backfill condition:

$$\mathbf{R}_r = [\gamma_{EV} (V_1 + V_2) + \gamma_{EH} (\mathbf{F}_T \sin\beta)] \times \mu \quad (4-13)$$

where

μ = minimum soil friction angle ϕ [$\tan \phi'_f$, $\tan \phi'_r$, or (for continuous reinforcement) $\tan \rho$]

External loads that increase sliding resistance should only be included if those loads are permanent.

Use the minimum EV load factor (= 1.00) in these equations because it results in minimum resistance for the sliding limit state.

- 5) Compare factored sliding resistance, R_r , to the factored driving force, P_d , to check that resistance is greater.
- 6) Check the capacity demand ratio (CDR) for sliding, $CDR = R_r/P_d$. If the $CDR < 1.0$, increase the reinforcement length, L , and repeat the calculations.

4.4.6.b Eccentricity Limit Check

The system of forces for checking the eccentricity at the base of the wall is shown on Figure 4-7. It should be noted that the weight and width of the wall facing is typically neglected in the calculations. Limiting eccentricity is a strength limit state check. The eccentricity limit check only applies the live load above the retained backfill, as shown in Figure 4-2.

The eccentricity, e , is the distance between the resultant foundation load and the center of the reinforced zone (i.e., $L/2$), as illustrated in Figure 4-7. The quantity e is calculated by summing the overturning and the resisting moments about the bottom, center of the base length, and dividing by the vertical load.

$$e = \frac{\sum M_D - \sum M_R}{\sum V} \quad (4-14)$$

Equations to compute eccentricity for two typical cases follow. These equations should be extended to include other loads and geometries, for other cases.

Wall with Horizontal Backslope: Calculation steps for the determination of the eccentricity beneath a wall with a horizontal backslope and a uniform live load surcharge are as follows, with respect to Figure 4-7.

Calculate nominal retained backfill and surcharge force resultants per unit width. See Equations 4-5 and 4-6 for walls with a horizontal backslope and uniform live load surcharge. See Equation 4-7 for walls with sloping backfill.

For a vertical wall, with horizontal backslope and uniform live load surcharge, calculate the eccentricity e as follows:

$$e = \frac{\gamma_{EH-MAX} F_1 \left(\frac{H}{3}\right) + \gamma_{LS} F_{q-LS} \left(\frac{H}{2}\right)}{\gamma_{EV-MIN} V_1} \quad (4-15)$$

Wall with Sloping Backfill: The eccentricity beneath a wall with a sloping backfill, and no surcharges, is calculated as follows, with respect to Figure 4-8.

Calculate e with factored loads. For a wall with a sloping backfill the eccentricity is equal to:

$$e = \frac{\gamma_{EH-MAX} F_T \cos\beta \left(\frac{h}{3}\right) - \gamma_{EH-MAX} F_T \sin\beta \left(\frac{L}{2}\right) - \gamma_{EV-MIN} V_2 \left(\frac{L}{6}\right)}{\gamma_{EV-MIN} V_1 + \gamma_{EV-MIN} V_2 + \gamma_{EH-MAX} F_T \sin\beta} \quad (4-16)$$

Eccentricity Check Criteria: The eccentricity, e , is considered acceptable if the calculated location of the resultant vertical force (based on factored loads) is within the middle one-half of the base width for soil foundations (i.e., $e_{max} = L / 4$) and middle three-fourths of the base width for rock foundations (i.e., $e_{max} = 3/8 L$). Therefore, for each strength limit load group, e must be less than e_{max} . If e is greater, than a longer length of reinforcement is required.

Examination of only the critical loading combination, as describe in Section 4.2, (i.e., use the minimum EV and maximum EH load factors) is sufficient for simple walls. Maximum permanent loads, minimum permanent loads, and total extremes should be checked for complex (geometry and/or loadings) walls to identify the critical loading.

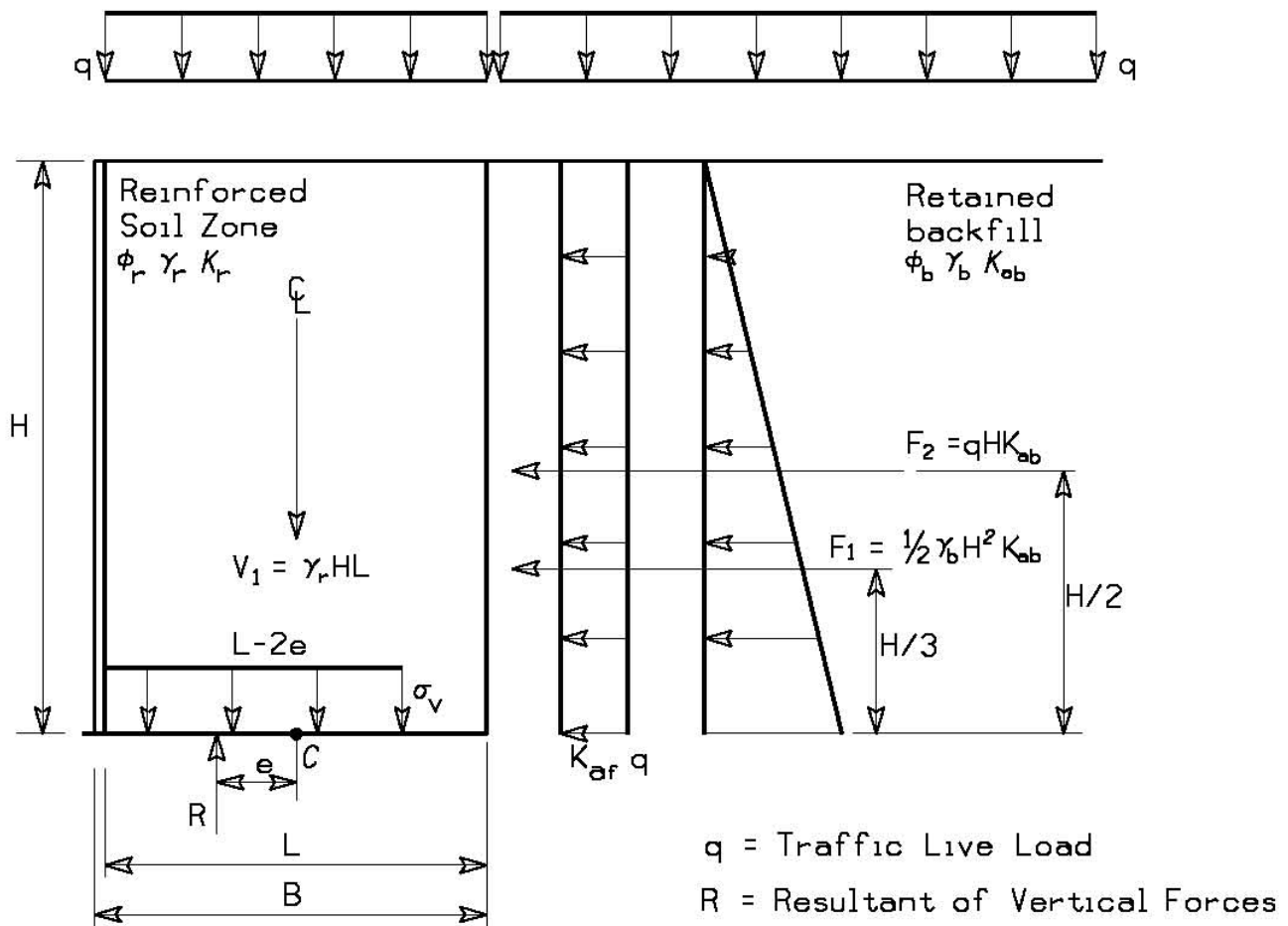

Figure 4-7. Calculation of eccentricity and vertical stress for bearing check, for horizontal backslope with traffic surcharge condition.

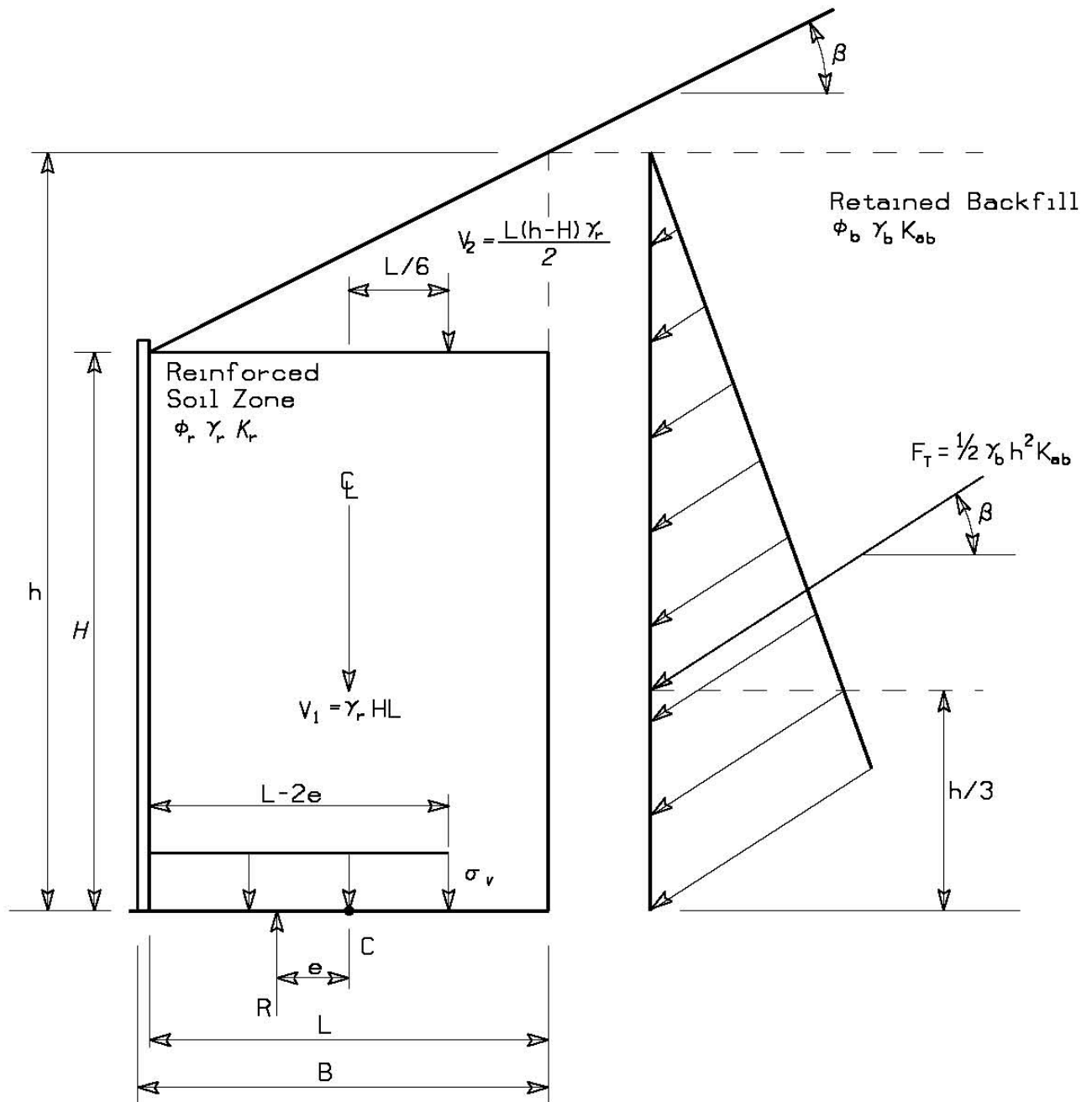

Figure 4-8. Calculation of eccentricity and vertical stress for bearing check, for sloping backslope condition.

4.4.6.c Evaluate Bearing on Foundation

Two modes of bearing capacity failure exist, general shear failure and local shear failure. Local shear is characterized by a punching or *squeezing* of the foundation soil when soft or loose soils exist below the wall.

Bearing calculations require both a strength limit state and a service limit state calculation. Strength limit calculations check that the factored bearing pressure is less than the factored bearing resistance. Service limit calculations are used to compute nominal bearing pressure for use in settlement calculations. It should be noted that the weight and width of the wall facing is typically neglected in the calculations. The bearing check applies live load above both the reinforced zone and the retained backfill, as shown in Figure 4-2.

General Shear. To prevent bearing failure on a uniform foundation soil, it is required that the factored vertical pressure at the base of the wall, as calculated with the uniform Meyerhof-type distribution, does not exceed the factored bearing resistance of the foundation soil:

$$q_R \geq q_{\text{uniform}} \quad (4-17)$$

The uniform vertical pressure is calculated as:

$$\sigma_v = \frac{\sum V}{L - 2e_B} \quad (4-18)$$

where:

- ΣV = summation of vertical forces
- L = width of foundation, equal to reinforcement length L
- e_B = eccentricity for bearing calculation (not equal to eccentricity check e)

This step, 6.c, requires a different computation of the eccentricity value computed in Step 6.a because different, i.e., maximum in lieu of minimum, load factor(s) are used. Also note that the bearing check applies the live load above both the reinforced zone and the retained backfill, as shown in Figure 4-2. In addition to walls founded on soil, a uniform vertical pressure is also used for walls founded on rock due to the flexibility of MSE walls and their limited ability to transmit moment (Article C11.10.5.4 {AASHTO, 2007}).

Calculation steps for MSE walls with either a horizontal backslope and uniform live load surcharge and for sloping backfills follow. Again, note that these equations should be extended to include other loads and geometries, for other cases.

- 1) Calculate the eccentricity, e_B , of the resulting force at the base of the wall. The e value from the eccentricity check, Step 6.a, cannot be used, Calculate e with factored loads. For a wall with horizontal backslope and uniform live load surcharge centered about the reinforced zone, the eccentricity is equal to:

$$e_B = \frac{\gamma_{EH-MAX} F_1 \left(\frac{H}{3}\right) + \gamma_{LS} F_{q-LS} \left(\frac{H}{2}\right)}{\gamma_{EV-MAX} V_1 + \gamma_{LS} q L} \quad (4-19)$$

where terms were previously defined. The maximum load factors for γ_{EH} and γ_{EV} are used to be consistent with the computation for σ_v (below) where maximum load factors results in the maximum vertical stress.

For walls with sloping backfill see Equation 4-16. Again, note that these equations should be extended to include other loads and geometries, for other cases.

Note that when checking the various load factors, and load combinations, the value of eccentricity, e_B , will vary. Also note that when the calculated value of eccentricity, e_B , is negative, a value of 0 should be carried forward in the design stress equation, i.e., set $L' = L$, per AASHTO C11.10.5.4 (2007).

- 2) Calculate the factored vertical stress σ_{v-F} at the base assuming Meyerhof-type distribution. For a horizontal backslope and uniform live load surcharge the factored bearing pressure is:

$$\sigma_{v-F} = \frac{\gamma_{EV-MAX} V_1 + \gamma_{LS} q L}{L - 2e_B} \quad (4-20)$$

This approach, proposed originally by Meyerhof, assumes that a stress distribution due to eccentric loading can be approximated by a uniform stress distribution over a reduced area at the base of the wall. This area is defined by a width equal to the wall width minus twice the eccentricity as shown in Figures 4-7 and 4-8. The effect of eccentricity and load inclination is addressed with use of the effective width, $L - 2e_B$, in lieu of the full width, L .

For wall with sloping backfill the factored bearing stress is:

$$q_{V-F} = \frac{\gamma_{EV-MAX} V_1 + \gamma_{EV-MAX} V_2 + \gamma_{EH-MAX} F_T \sin\beta}{L - 2e_B} \quad (4-21)$$

Note that $(L - 2e_B)$ is set equal to L when the value of eccentricity is negative. A negative value of eccentricity may be found for some extreme geometries, e.g. a wall section with very long reinforcements and a steep, infinite backslope. **Note that when checking the various load factors and load combinations the value of eccentricity, e_B , will vary and a critical value must be determined by comparisons of applicable load combinations.**

Where applicable, in the computation of bearing stress, σ_{V-F} , include the influence of factored surcharge and factored concentrated loads. Maintain consistency with loads and load factors used in the eccentricity calculation and corresponding bearing stress calculation.

- 3) Determine the nominal bearing resistance, q_n , Equation 10.6.3.1.2a-1 of AASHTO (2007). For a level grade in front of a MSE wall and no groundwater influence:

$$q_n = c_f N_c + 0.5L'\gamma_f N_\gamma \quad (4-22)$$

where: c_f = the cohesion of the foundation soil

γ_f = the unit weight of the foundation soil

N_c and N_γ = dimensionless bearing capacity coefficients

L' = effective foundation width, equal to $L - 2e_B$; set L' equal to L if e_B is a negative value

The dimensionless bearing capacity factors can be obtained from Table 10.6.3.1.2a-1 of AASHTO (2007) and, for convenience, are shown in Table 4-6. Modifications to q_n (Equation 4-22) for a ground surface slope and for high groundwater level are provided in 10.6.3.1.2 AASHTO (2007). The beneficial effect of wall embedment is neglected. (Note: for excessive embedment (i.e., embedment greater than the minimum requirements, see Table 2-2), partial embedment may be considered in the determination of q_n provided that the fill in front of the wall is placed and compacted as the reinforced fill is placed and all possible failure modes are examined. Bearing capacity is addressed in detail in the following two NHI courses: 132037 Shallow Foundations, and reference manual FHWA NHI-01-023 (Munfakh et al., 2001); and 132012 Soils & Foundations, and reference manual Volume I, FHWA NHI-06-089 (Samtani and Nowatzki, 2006).

Table 4-6. Bearing Resistance Factors
(Table 10.6.3.1.2a-1, AASHTO {2007}).

ϕ	N_c	N_q	N_γ	ϕ	N_c	N_q	N_γ
0	5.14	1.0	0.0	23	18.1	8.7	8.2
1	5.4	1.1	0.1	24	19.3	9.6	9.4
2	5.6	1.2	0.2	25	20.7	10.7	10.9
3	5.9	1.3	0.2	26	22.3	11.9	12.5
4	6.2	1.4	0.3	27	23.9	13.2	14.5
5	6.5	1.6	0.5	28	25.8	14.7	16.7
6	6.8	1.7	0.6	29	27.9	16.4	19.3
7	7.2	1.9	0.7	30	30.1	18.4	22.4
8	7.5	2.1	0.9	31	32.7	20.6	25.9
9	7.9	2.3	1.0	32	35.5	23.2	30.2
10	8.4	2.5	1.2	33	38.6	26.1	35.2
11	8.8	2.7	1.4	34	42.2	29.4	41.1
12	9.3	3.0	1.7	35	46.1	33.3	48.0
13	9.8	3.3	2.0	36	50.6	37.8	56.3
14	10.4	3.6	2.3	37	55.6	42.9	66.2
15	11.0	3.9	2.7	38	61.4	48.9	78.0
16	11.6	4.3	3.1	39	37.9	56.0	92.3
17	12.3	4.8	3.5	40	75.3	64.2	109.4
18	13.1	5.3	4.1	41	83.9	73.9	130.2
19	13.9	5.8	4.7	42	93.7	85.4	155.6
20	14.8	6.4	5.4	43	105.1	99.0	186.5
21	15.8	7.1	6.2	44	118.4	115.3	224.6
22	16.9	7.8	7.1	45	133.9	134.9	271.8
Note:							
N_c (Prandtl, 1921), N_q (Reisner, 1924), and N_γ (Vesic, 1975). N_q is embedment term, which is typically not used in MSE wall design.							

- 4) Check that factored bearing resistance is greater than the factored bearing stress, i.e., $q_R \geq q_{V-F}$. The factored bearing resistance (q_R) is given as:

$$q_R = \phi q_n \quad (4-23)$$

where:

ϕ = resistance factor, for MSE walls this factor is 0.65 (Table 11.5.6-1, AASHTO {2007})

- 5) As indicated in step 2) and step 3), q_{V-F} can be decreased and q_R increased by lengthening the reinforcements, though only marginally. The nominal bearing resistance often may be increased by additional subsurface investigation and better definition of the foundation soil properties. If adequate support conditions cannot be achieved or lengthening reinforcements significantly increases costs, improvement of the foundation soil may be considered (dynamic compaction, soil replacement, stone columns, precompression, etc.) – see FHWA Ground Improvement Methods reference manuals NHI-06-019 and NHI-06-020 (Elias et al., 2006).

Local Shear, Punching Shear And Lateral Squeeze. Local shear is a transition between general shear and punching shear, which can occur in loose or compressible soils, in weak soils under slow (drained) loading. If local shear or punching shear failure is possible, Section 10.6.3.1.2b of AASHTO (2007) requires the use of reduced shear strength parameters for calculating the nominal bearing resistance. The reduced effective stress cohesion, c^* is set equal to $0.67c'$. The reduced effective stress soil friction angle, ϕ^* is set equal to $\tan^{-1}(0.67 \tan \phi'_f)$.

Lateral squeeze is a special case of local shear that can occur when bearing on a weak cohesive soil layer overlying a firm soil layer. Lateral squeeze failure results in significant horizontal movement of the soil under the structure.

To prevent local shear of structures bearing on weak cohesive soils it is required that:

$$\gamma_r H \leq 3 c_u \quad (4-24)$$

where γ_r is the nominal unit weight of the reinforced fill, H is the height of the wall and c_u is the nominal total stress cohesion of the foundation soil.

If adequate support conditions cannot be achieved, either the soft soils should be removed or ground improvement of the foundation soils is required. Local shear, as well as bearing on

two layered soil systems in undrained and drained loading, are addressed in Section 10.6.3.1.2 of AASHTO (2007). Local shear and lateral squeeze is addressed in detail in NHI course 132012 Soils & Foundations, and reference manual Volume II, FHWA NHI-06-088 (Samtani and Nowatzki, 2006).

4.4.6.d Settlement Estimate

Conventional settlement analyses should be carried out to ensure that immediate, consolidation, and secondary settlement of the wall are less than the performance requirements of the project (see FHWA NHI-06-088 and NHI-06-089, *Soils and Foundations Reference manuals* {Samtani and Nowatzki, 2006}). Settlement is evaluated under bearing pressure computed at a Service I limit state.

Significant estimated post-construction foundation settlements indicate that the planned top of wall elevations need to be adjusted. This can be accomplished by increasing the top of wall elevations during wall design, or by providing height adjustment within the top of wall coping, and/or by delaying the casting of the top row of panels to the end of erection. The required height of the top row, would then be determined with possible further allowance for continuing settlements. Significant differential settlements (greater than 1/100), indicate the need of slip joints, which allow for independent vertical movement of adjacent precast panels. Where the anticipated settlements and their duration, cannot be accommodated by these measures, consideration must be given to ground improvement techniques such as wick drains, stone columns, dynamic compaction, the use of lightweight fill or the implementation of two-phased construction in which the first phase facing is typically a wire facing.

4.4.7 Step 7 –EVALUATE INTERNAL STABILITY

Internal failure of a MSE wall can occur in two different ways:

- The tensile forces (and, in the case of rigid reinforcements, the shear forces) in the inclusions become so large that the inclusions elongate excessively or break, leading to large movements and/or possible collapse of the structure. This mode of failure is called failure by elongation or breakage of the reinforcements.
- The tensile forces in the reinforcements become larger than the pullout resistance, leading to large movements and/or possible collapse of the structure. This mode of failure is called failure by pullout.

The process of sizing and designing to preclude internal failure, therefore, consists of determining the maximum developed tension forces, their location along a locus of critical slip surfaces and the resistance provided by the reinforcements both in pullout capacity and tensile strength. Internal stability also includes an evaluation of serviceability requirements

such as tolerable lateral movement of supported structures and control of downdrag stress on reinforcement connections.

4.4.7.a Select Type of Soil Reinforcement

Soil reinforcements are either inextensible (i.e., mostly metallic) or extensible (i.e., mostly polymeric materials), as discussed in Chapter 2. The internal wall design model varies by material type due to their extensibility relative to soil at failure. Therefore, the choice of material type should be made at this step of the design. The variations are: whether life prediction is based on metal corrosion or polymer degradation; critical failure plane geometry assumed for design; and lateral stress used for design. Distinction can be made between the characteristics of inextensible and extensible reinforcements, as follows.

Design Methods, Inextensible (e.g., Metallic) Reinforcements

The current method of limit equilibrium analysis uses a coherent gravity structure approach to determine external stability of the reinforced mass, similar to the analysis for any conventional or traditional gravity structure. For internal stability evaluations, it considers a bi-linear failure surface that divides the reinforced zone in active and resistant zones and requires that an equilibrium state be achieved for successful design.

The lateral earth pressure distribution for **external stability**, is assumed to be based on Coulomb's method with a wall friction angle δ assumed to be zero. For **internal stability** lateral pressure varying from a multiple of K_a to an active earth pressure state, K_a is used for design. Previous research (FHWA RD 89-043) has focused on developing the state of stress for internal stability, as a function of K_a , type of reinforcement used (geotextile, geogrid, metal strip or metal grid), and depth. The results from these and more recent (Allen et al., 2001) efforts have been synthesized in a *simplified method*, which will be used throughout this manual.

Design Methods, Extensible (e.g., Geosynthetic) Reinforcements

For **external stability** calculations, the current method assumes an earth pressure distribution, consistent with the method used for inextensible reinforcements.

For **internal stability** computations using the *simplified method*, the internal coefficient of earth pressure is again a function of the type of reinforcement, where the minimum coefficient (K_a) is used for walls constructed with continuous sheets of geotextiles and geogrids. For internal stability, a Rankine failure surface is considered, because the extensible reinforcements can elongate more than the soil, before failure, and do not significantly modify the shape of the soil failure surface.

4.4.7.b Define Critical Slip Surface

The critical slip surface in a simple reinforced soil wall is assumed to coincide with the locus of the maximum tensile force, T_{MAX} , in each reinforcement layer. The shape and location of the critical failure surface is based upon instrumented structures and theoretical studies.

This critical failure surface has been assumed to be approximately bilinear in the case of inextensible reinforcements (Figure 4-9), approximately linear in the case of extensible reinforcements (Figure 4-9), and passes through the toe of the wall in both cases.

When failure develops, the reinforcement may elongate and be deformed at its intersection with the failure surface. As a result, the tensile force in the reinforcement would increase and rotate. Consequently, the component in the direction of the failure surface would increase and the normal component may increase or decrease. Elongation and rotation of the reinforcements may be negligible for stiff inextensible reinforcements such as steel strips but may be significant with geosynthetics. Any reinforcement rotation is ignored for internal wall stability calculations with the simplified method. However, reinforcement rotation may be considered in compound slope stability analysis (see Chapters 8 and 9).

For extensible reinforcements, the Coulomb earth pressure relationship shown on Figure 4-5 should be used to define the failure surface, per AASHTO Figure 11.10.6.3.1-1 (2007), where the wall front batter from vertical is greater than 10 degrees.

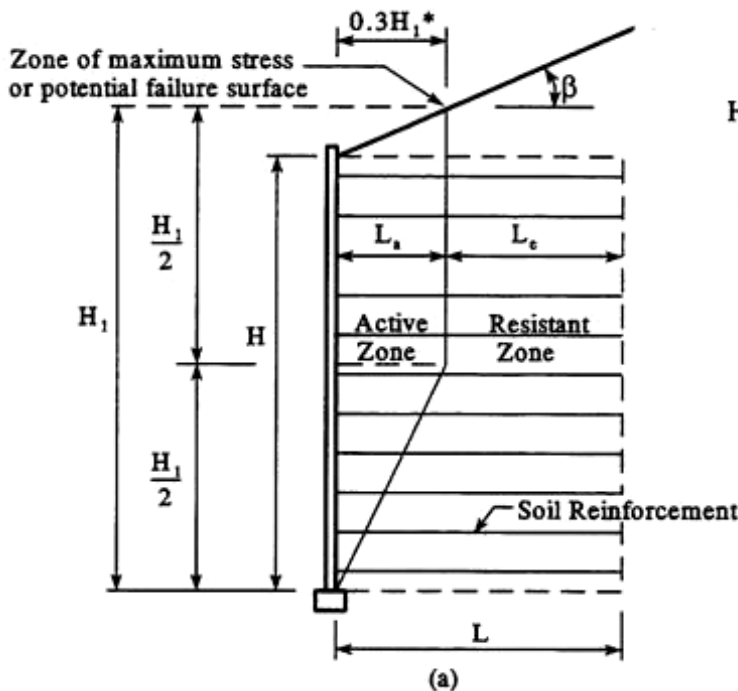

$$H_1 = H + \frac{\tan \beta \times 0.3H}{1 - 0.3 \tan \beta}$$

* If wall face is battered, an offset of $0.3H_1$ is still required, and the upper portion of the zone of maximum stress should be parallel to the wall face

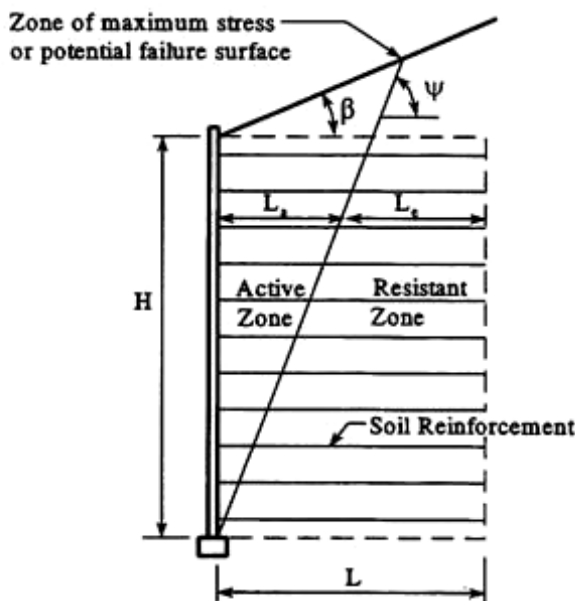

For vertical face

$$\psi = 45 + \frac{\phi}{2}$$

For walls with a face batter angle (θ) 10° or more from the vertical,

$$\tan(\psi - \theta) = \frac{-\tan(\phi - \beta) + \sqrt{\tan(\phi - \beta)[\tan(\phi - \beta) + \cot(\phi + \theta - 90)][1 + \tan(\delta + 90 - \theta)\cot(\phi + \theta - 90)]}}{1 + \tan(\delta + 90 - \theta)[\tan(\phi - \beta) + \cot(\phi + \theta - 90)]}$$

with $\delta = \beta$

θ = wall batter angle (b)

For wall with a broken backslope, use $\delta = \beta_a$

Figure 4-9. Location of potential failure surface for internal stability design of MSE Walls (a) inextensible reinforcements and (b) extensible reinforcements.

4.4.7.c Define Unfactored Loads

The primary sources of internal loading of an MSE wall is the earth pressure from the reinforced fill and any surcharge loadings on top of the reinforced zone. The unfactored loads for MSE walls may include loads due to, vertical earth pressure (EV), live load surcharge (LS), and earth surcharge (ES). Water, seismic, and vehicle impact loads should also be evaluated, as appropriate.

Research studies (Collin, 1986; Christopher et al., 1990; Allen et al., 2001) have indicated that the maximum tensile force is primarily related to the type of reinforcement in the MSE wall, which, in turn, is a function of the modulus, extensibility and density of reinforcement. Based on this research, a relationship between the type of the reinforcement and the overburden stress has been developed, and shown in Figure 4-10. The K_r/K_a ratio for metallic (inextensible) reinforcements decreases from the top of the reinforced wall fill to a constant value 20 ft (6 m) below this elevation. In contrast to inextensible reinforcements, the K_r/K_a for extensible (e.g., geosynthetic) reinforcement is a constant. Note that the resulting K_r/K_a ratio is referenced to the top of the wall at the face, excluding any copings and appurtenances (i.e., the top of the reinforced soil zone at the face) for both walls with level and with sloping backfills. The K_r/K_a starting elevation for an MSE wall supporting a spread footing bridge abutment is the top of the backfill, see Chapter 6 and appended design example.

The simplified approach used herein was developed in order to avoid iterative design procedures required by some of the complex refinements of the available methods i.e., the coherent gravity method (AASHTO, 1994 Interims) and the structural stiffness method (FHWA RD 89-043, Christopher et al., 1990). The *simplified method* (a.k.a. *simplified coherent gravity method*) (Elias and Christopher, 1997; Allen et al., 2001) is based on the same empirical data used to develop these two methods.

Figure 4-10 was prepared by back analysis of the lateral stress ratio K_r from available field data where stresses in the reinforcements were measured and normalized as a function of the Rankine active earth pressure coefficient, K_a . The Rankine active earth pressure theory assumes lateral pressure is independent of backfill slope and interface friction. The ratios shown on Figure 4-10 correspond to values representative of the specific reinforcement systems that are known to give satisfactory results assuming that the vertical stress is equal to the weight of the overburden (γH). This provides a simplified evaluation method for all cohesionless reinforced fill walls. Future data may lead to modifications in Figure 4-10, including relationships for newly developed reinforcement types, effect of full height panels, etc. These relationships can be developed by instrumenting structures and using numerical models to verify the K_r/K_a ratio for routine and complex walls.

The lateral earth pressure coefficient K_r is determined by applying a multiplier to the active earth pressure coefficient. The active earth pressure coefficient is determined using a Coulomb earth pressure relationship, assuming no wall friction and a β angle equal to zero (i.e., equivalent to the Rankine earth pressure coefficient). For a vertical wall the earth pressure therefore reduces to the Rankine equation:

$$K_a = \tan^2 \left(45 - \frac{\phi'_r}{2} \right) \quad (4-25)$$

For wall face batters equal to or greater than 10° from the vertical, the following simplified form of the Coulomb equation can be used:

$$K_a = \frac{\sin^2(\theta + \phi'_r)}{\sin^3 \theta \left[1 + \frac{\sin \phi'_r}{\sin \theta} \right]} \quad (4-26)$$

where θ is the inclination of the back of the facing as measured from the horizontal starting in front of the wall, as shown in Figure 4-5. Commentary C11.10.6.2.1 AASHTO (2007) states that above equation can be used for battered walls. The 10° value recommendation is consistent with the equation to determine the failure surface location for walls with 10° or greater batter (C11.10.6.3.1, AASHTO {2007}).

The stress, σ_2 , due to a sloping backfill on top of an MSE wall can be determined as shown in Figure 4-11. An equivalent soil height, S , is computed based upon the slope geometry. The value of S_{eq} should not exceed the slope height for broken back sloping fills. A reinforcement length of $0.7H$ is used to compute the sloping backfill stress, σ_2 , on the soil reinforcement, as a greater length would only have minimal effect on the reinforcement. The vertical stress is equal to the product equivalent soil height and the reinforced fill unit weight, and is uniformly applied across the top of the MSE zone.

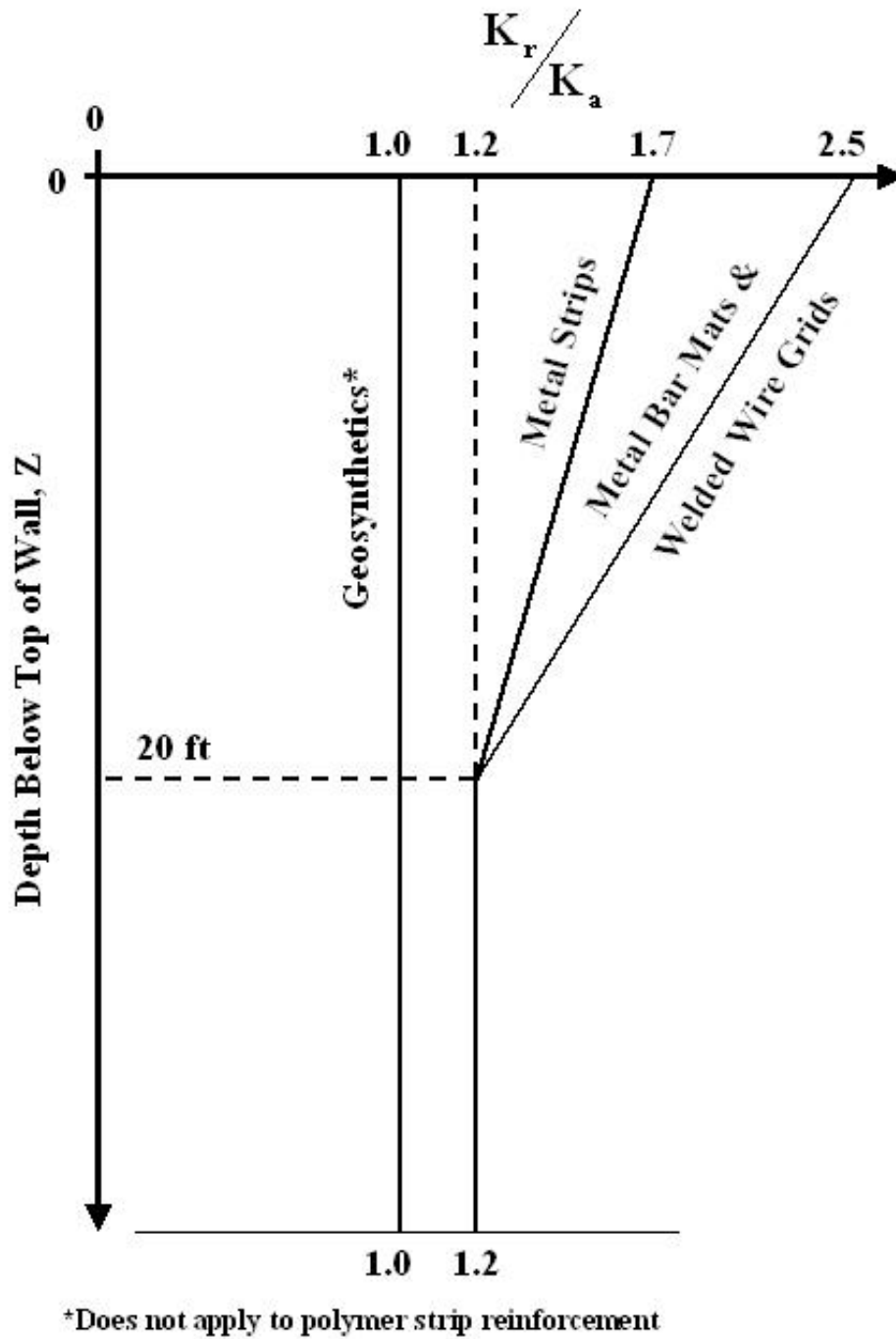

Figure 4-10. Variation of the coefficient of lateral stress ratio (K_r/K_a) with depth in a MSE wall (Elias and Christopher, 1997; AASHTO; 2002; & after AASHTO, 2007).

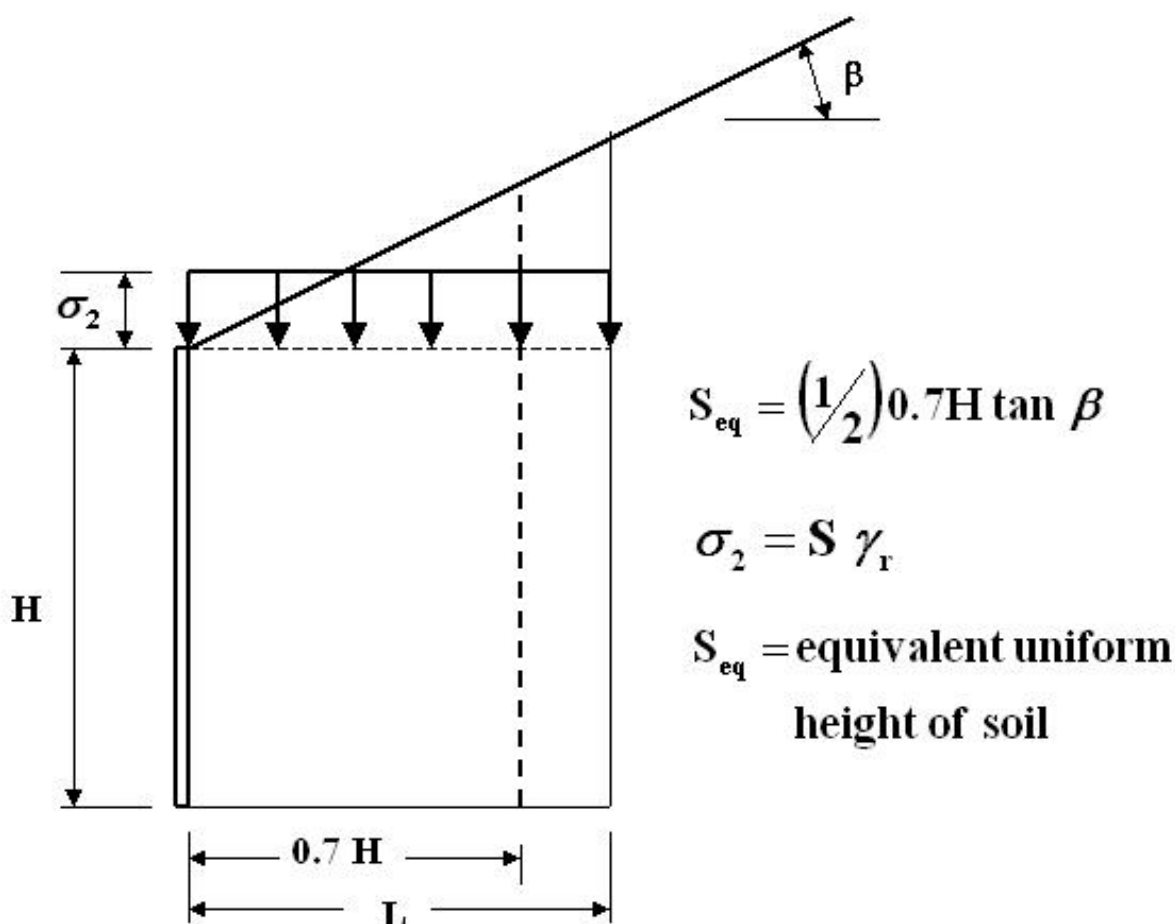

Figure 4-11. Calculation of vertical stress for sloping backfill conditions for internal stability.

4.4.7.d Establish Vertical Layout of Soil Reinforcements

Use of a constant reinforcement section and spacing for the full height of the wall usually gives more reinforcement in the upper portion of the wall than is required for stability. Therefore, a more economical design may be possible by varying the reinforcement density with depth. However, to provide a coherent reinforced soil zone, vertical spacing of reinforcement should not exceed 32 in. (800 mm).

There are generally two practical ways to accomplish this for MSE walls:

- For reinforcements consisting of strips, grids, or mats used with segmental precast concrete facings, the vertical spacing is maintained constant and the reinforcement

density is increased with depth by increasing the number and/or the size of the reinforcements. For instance, the typical horizontal spacing of 2-in. (50 mm) x 5/32-in. (4 mm) strips is 30 in. (0.75 m), but this can be decreased by adding horizontal reinforcement locations.

- For continuous sheet reinforcements, made of geotextiles or geogrids, a common way of varying the reinforcement density T_{al}/S_v is to change the vertical spacing S_v , especially if wrapped facing is used, because it easily accommodates spacing variations. The range of acceptable spacing is governed by consideration of placement and compaction of the backfill (e.g., S_v taken as 1, 2 or 3 times the compacted lift thickness). The reinforcement density T_{al}/S_v can also be varied by changing the strength (T_{al}) especially if wrapped facing techniques requiring a constant wrap height are used.

Low-to medium-height walls (e.g., < 16 ft {5 m}) are usually constructed with one strength geosynthetic. Taller walls use multiple strength geosynthetics. For example the 41 ft (12.6 m) high Seattle preload wall used four strengths of geotextiles (Allen et al., 1992). A maximum spacing of 16 in. (400 mm) is typical for wrapped faced geosynthetic walls, although a smaller spacing may be desirable to minimize bulging.

For walls constructed with modular blocks, the maximum vertical spacing of reinforcement should be limited to two times the block depth (front face to back face) or 32 in. (810 mm), which ever is less, to assure construction and long-term stability. The top row of reinforcement should be limited to 1.5 the block depth (e.g. one unit plus a cap unit). (AASHTO 11.10.2.3.1 {AASHTO, 2007}).

For large face units, such as 3 ft by 3 ft (0.9 m by 0.9 m) gabions, a vertical spacing equal to the face height (i.e., 3 ft {0.9 m}) is typically used. This spacing slightly exceeds the limit noted above, but this may be offset by the contributions of the large facing unit to internal (i.e., bulging) stability.

4.4.7.e Calculate Factored Tensile Forces in the Reinforcement Layers

e.1 Calculate Horizontal Stress

For internal stability analysis, the distribution of horizontal stress, σ_H , is first established. The horizontal stress at any given depth within the reinforced soil zone is expressed as follows:

$$\sigma_H = K_r [\sigma_v] + \Delta\sigma_H \quad (4-27)$$

where K_r is the coefficient of lateral earth pressure in the reinforced soil zone and is obtained from Figure 4-10, σ_v is the factored vertical pressure at the depth of interest, and $\Delta\sigma_h$ is the supplemental factored horizontal stress due to external surcharges.

For internal stability analysis, the following assumptions are made in the computation of factored vertical pressure, σ_v :

1. Vertical pressure due to the weight of the reinforced soil zone is assigned a load type “EV” with a corresponding (maximum) load factor, $\gamma_{P-EV} = 1.35$. The maximum load factor of 1.35, and not the minimum load factor of 1.00, is always used to find the critical stress.
2. Any vertical surcharge above the reinforced soil zone that is due to soil or considered as an equivalent soil surcharge is assigned a load type “EV.” In this scenario, a live load traffic surcharge that is represented by an equivalent uniform soil surcharge of height h_{eq} is assumed as load type “EV.” This is in contrast to the external stability analysis where the live load traffic surcharge is assumed as load type “LS” because in external stability analysis the MSE wall is assumed to be a rigid block. For internal stability analysis, the assumption of load type “EV” is used so that the amount of soil reinforcement within the reinforced soil zone is approximately the same as obtained using past working stress design approach (i.e., calibration by fitting).
3. The unit weight of the equivalent soil surcharge is assumed to be the same as the unit weight of the reinforced soil zone, γ_r , which is generally greater than or equal to the unit weight of the retained backfill.
4. Any vertical surcharge that is due to non-soil source is assigned a load type “ES.” Example of such a load is the bearing pressure under a spread footing on top of reinforced soil zone. However, the application of the load factor of $\gamma_{P-ES} = 1.50$ that is assigned to load type “ES” is a function of how the vertical pressures are computed as follows:
 - If the vertical pressures are based on nominal (i.e., unfactored) loads, then use $\gamma_{P-ES} = 1.50$.
 - If the vertical pressures were based on factored loads, then use $\gamma_{P-ES} = 1.00$. This is because once the loads are factored they should not be factored again.

It is recommended that the factored vertical pressure be evaluated using both the above approaches and the larger value chosen for analysis.

The supplemental factored horizontal pressure, $\Delta\sigma_h$, could be from a variety of sources. Two examples of supplemental horizontal pressures are as follows:

1. Horizontal pressures due to the horizontal (shear) stresses at the bottom of a spread footing on top of reinforced soil zone.
2. Horizontal pressures from deep foundation elements extending through the reinforced soil zone.

Supplemental horizontal pressures are assigned a load type “ES” since they represent surcharges on or within the reinforced soil zone. However, similar to the vertical pressures due to non-soil loads, the application of the maximum load factor of $\gamma_{P-ES} = 1.50$ that is assigned to load type “ES” is a function of how the horizontal pressures are computed as follows:

- If the horizontal pressures are based on nominal (i.e., unfactored) loads, then use $\gamma_{ES-MAX} = 1.50$.
- If the horizontal pressures were based on factored loads, then use $\gamma_{P-ES} = 1.00$. This is because once the loads are factored they should not be factored again.

As with vertical pressure, it is recommended that the factored horizontal pressure be evaluated using both the above approaches and the larger value chosen for analysis.

The application of the above guidance is illustrated below for four MSE wall configurations ranging from simple to complex geometries. The logic used in development of these equations can be extended to any other MSE wall configuration with complex system of surcharges.

Example 1: MSE wall with level backfill and no surcharge. This represents the simplest MSE wall configuration for which the horizontal stress at any given depth Z below the top of the reinforced soil zone is given as follows:

$$\sigma_H = K_r [(\gamma_r Z) \gamma_{EV-MAX}] \quad (4-28)$$

where, γ_r is the unit weight of soil in the reinforced soil zone, and γ_{EV-MAX} is the maximum load factor (=1.35) for load type “EV.” The value of K_r is obtained by assuming that: (i) the variation of K_r/K_a ratio shown in Figure 4-10 starts from the top of the reinforced soil zone, and (ii) K_a is computed using the Rankine formula (Eq. 4-25).

Example 2: MSE wall with sloping backfill. This configuration is commonly used for side-hill retaining wall applications. Example of this configuration is shown in Figure 4-10. As shown in Figure 4-11, the sloping surcharge is approximated by an equivalent uniform soil surcharge of height, S_{eq} . For this case, the horizontal stress at any depth Z below the top of the reinforced soil zone can be written as follows:

$$\sigma_H = K_r [\gamma_r (Z + S_{eq}) \gamma_{EV-MAX}] \quad (4-29)$$

The value of K_r is obtained by assuming that: (i) the variation of K_r/K_a ratio shown in Figure 4-10 starts from the top of the reinforced soil zone, and (ii) K_a is computed using the Rankine formula (Eq. 4-25) assuming that the backfill is level. Use of Equation 4-29 is demonstrated in Example Problem E-3 in Appendix E.

Example 3: MSE wall with level backfill and live load surcharge. This configuration is commonly used for grade-separated roadways. Assuming that the live load is expressed as an equivalent uniform soil surcharge of height, h_{eq} , (equal to 2 ft) the horizontal stress at any depth Z below the top of the reinforced soil zone can be written as follows:

$$\sigma_H = K_r [\gamma_r (Z + h_{eq}) \gamma_{EV-MAX}] \quad (4-30)$$

The value of K_r is obtained by assuming that: (i) the variation of K_r/K_a ratio shown in Figure 4-10 starts from the top of the reinforced soil zone, and (ii) K_a is computed using the Rankine formula (Eq. 4-25). Use of Equation 4-30 is demonstrated in Example Problem E-4 in Appendix E.

Example 4: Bridge abutment with a spread footing on top of MSE wall. In this configuration the bridge superstructure rests on a spread footing on top of a MSE wall. This configuration is discussed in detail in Chapter 6. It is included here as an example of a complex system of surcharges that can be used to explain the computation of horizontal stress for such cases. For development of the equation of horizontal stress, refer to Figures 4-12 and 4-13. Assumptions are that the live load is expressed as an equivalent uniform soil surcharge of height, h_{eq} , as per Table 4-4, the height of the roadway fill above the reinforced soil zone is h , and $\Delta\sigma_v$ and $\Delta\sigma_H$ increase T_{MAX} . Then,

the horizontal stress at any depth Z below the top of the reinforced soil zone can be written as follows:

$$\sigma_H = K_r [\gamma_r (Z + h + h_{eq}) \gamma_{EV-MAX} + (\Delta\sigma_{v-footing}) \gamma_{P-ES}] + (\Delta\sigma_H) \gamma_{P-ES} \quad (4-31)$$

where $\Delta\sigma_v$ and $\Delta\sigma_H$ are the vertical (normal) and horizontal (shear) pressures at the bottom of the spread footing. As noted earlier, the value of γ_{P-ES} is 1.50 if nominal (i.e., unfactored) pressures are used, and is 1.00 if factored pressures are used with the final value being chosen based on larger values of $(\Delta\sigma_{v-footing})\gamma_{P-ES}$ and $(\Delta\sigma_H)\gamma_{P-ES}$.

The value of K_r is obtained by assuming that: (i) the variation of K_r/K_a ratio shown in Figure 4-10 starts from the finished pavement grade behind the spread footing, and (ii) K_a is computed using the Rankine formula (Eq. 4-25). Use of Equation 4-31 is demonstrated in Example Problem E-5 in Appendix E.

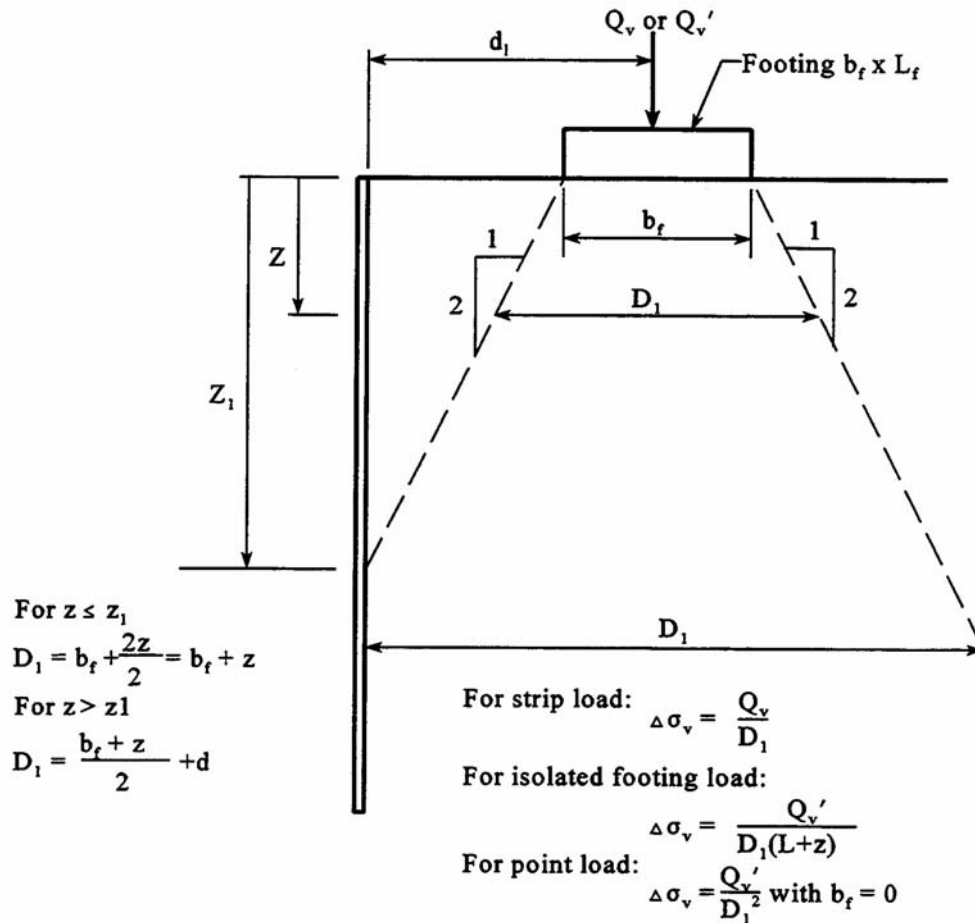

Where: D_1 = Effective width of applied load at any depth, calculated as shown above
 b_f = Width of applied load. For footings which are eccentrically loaded (e.g., bridge abutment footings), set b_f equal to the equivalent footing width B' by reducing it by $2e'$, where e' is the eccentricity of the footing load (i.e., $b_f - 2e'$).
 L_f = Length of footing
 Q_v = Load per linear feet of strip footing
 Q_v' = Load on isolated rectangular footing or point load
 z_1 = Depth where effective width intersects back of wall face = $2d_1 - b_f$

Assume the increased vertical stress due to the surcharge load has no influence on stresses used to evaluate internal stability if the surcharge load is located behind the reinforced soil mass. For external stability, assume the surcharge has no influence if it is located outside the active zone behind the wall.

Figure 4-12. Distribution of stress from concentrated vertical load for internal and external stability calculations.

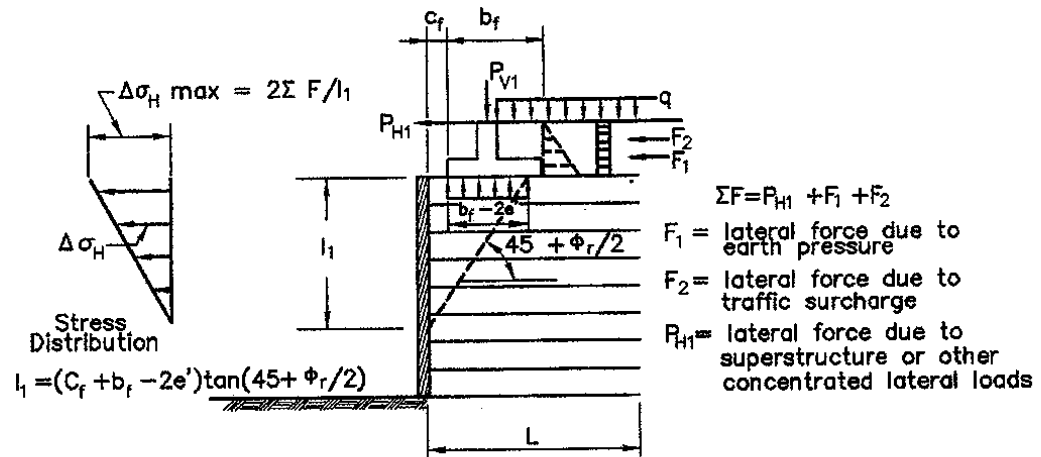

e' = eccentricity of load on footing

a. Distribution of Stress for Internal Stability Calculations.

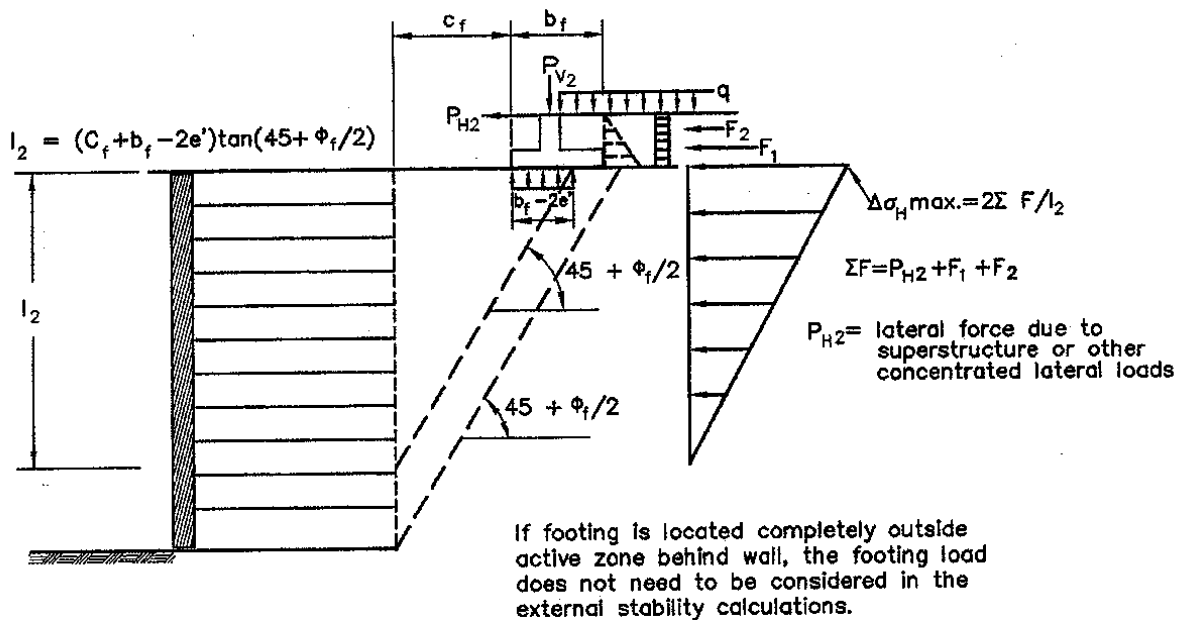

b. Distribution of Stress for External Stability Calculations.

Figure 4-13. Distribution of stresses from concentrated horizontal loads.

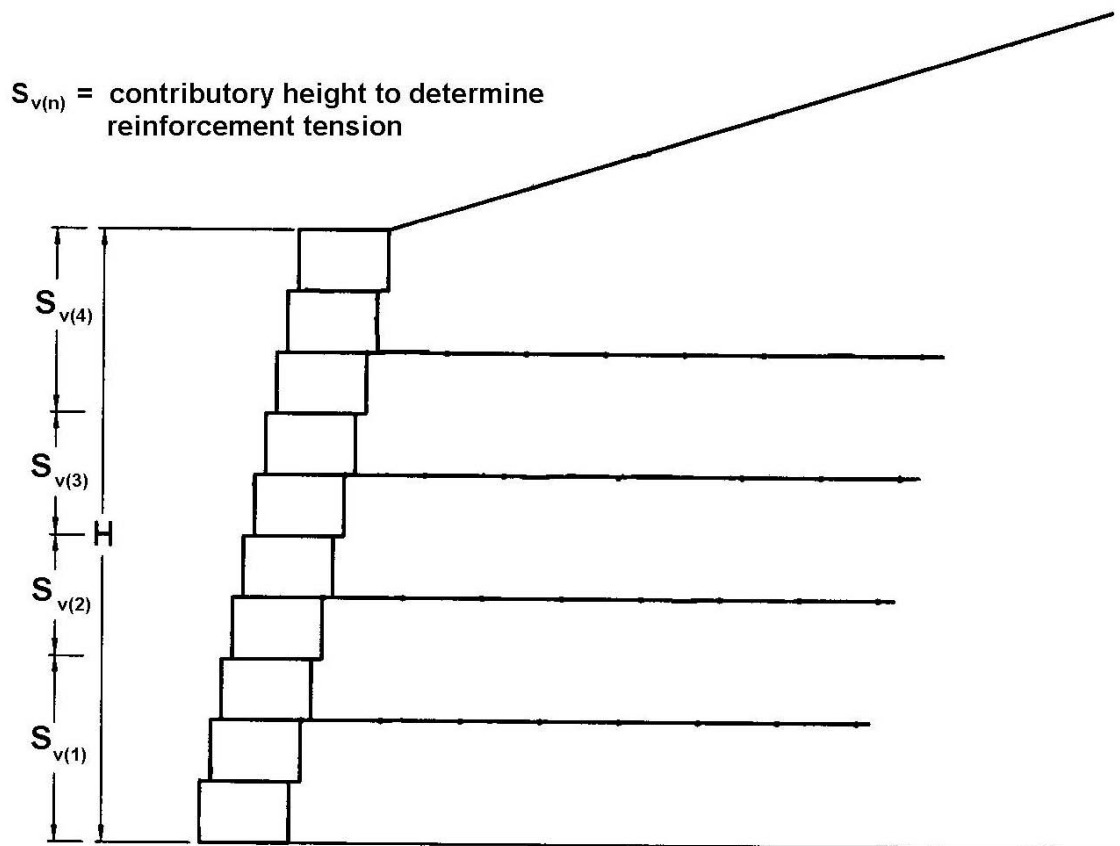

Figure 4-14. Reinforcement load contributory height.

e.2 Calculate Maximum Tension, T_{MAX}

Calculate the maximum factored tension T_{MAX} in each reinforcement layer per unit width of wall based on the vertical spacing S_v from:

$$T_{MAX} = \sigma_H S_v \quad (\text{in force per unit reinforcement width \{kips/ft\}}) \quad (4-32a)$$

The term S_v is equal to the vertical reinforcement spacing for a layer where vertically adjacent reinforcements are equally spaced from the layer under consideration. In this case, σ_H , calculated at the level of the reinforcement, is at the center of the contributory height. The contributory height is defined as the midpoint between vertically adjacent reinforcement elevations, except for the top and bottom layers reinforcement.

For the top and bottom layers of reinforcement, S_v is the distance from top or bottom of wall, respectively, to the midpoint between the first and second layer (from top or bottom of wall, respectively) of reinforcement. S_v distances are illustrated in Figure 4-14.

The maximum reinforcement tension, T_{MAX} , for the top and bottom layers of reinforcement, and for intermediate layers that do not have equally spaced adjacent layers, is calculated as the product of the contributory height and the average factored horizontal stress acting upon that contributory height. The average stress can be calculated based upon the tributary trapezoidal area (i.e. average of the stress at top and at the bottom of the contributory height) or at the midpoint of the contributory height, as illustrated in Figure 4-14.

Alternatively, for discrete reinforcements (metal strips, bar mats, geogrids, etc.) T_{MAX} (force per unit width) may be calculated at each level as $P_{TMAX-UWR}$ in terms of force per unit width of reinforcement, as:

$$P_{TMAX-UWR} = \frac{\sigma_H S_v}{R_c} \quad (4-32b)$$

where:

R_c = ratio of gross width of strip, sheet, or grid to the center-to-center horizontal spacing between the strips, sheets, or grids (see Eq. 3-9 and Figure 3-3); e.g., $R_c = 1$ for full coverage reinforcement.

For discrete reinforcements of known spacing and segmental precast concrete facing of known panel dimensions, T_{MAX} (force per unit width) can alternatively be calculated per discrete reinforcement, P_{TMAX-D} , per panel width, defined as.

$$P_{TMAX-D} = \frac{\sigma_H S_v W_p}{N_p} \quad (4-32c)$$

where:

P_{TMAX-D} = maximum factored load in discrete reinforcement element
 W_p = width of panel
 N_p = number of discrete reinforcements per panel width (e.g., 2, 3, etc.)

4.4.7.f Calculate Soil Reinforcement Resistance

The procedure and discussion on definition of nominal long-term reinforcement design strength (T_{al}), for both steel and geosynthetic reinforcements, are presented in Section 3.5 of this manual. The factored soil resistance is the product of the nominal long-term strength, coverage ratio, and applicable resistance factor, ϕ . The resistance factors for tensile rupture

of MSE wall soil reinforcements are summarized in Table 4-7. The factored tensile resistance, T_r , is equal to:

$$T_r = \phi T_{al} \quad (4-33)$$

T_{al} (as noted in Section 3.5) and T_r may be expressed in terms of strength per unit width of wall, per reinforcement element, or per unit reinforcement width.

Table 4-7. Resistance Factors, ϕ , for Tensile and Pullout Resistance for MSE Walls
(after Table 11.5.6-1, AASHTO {2007}).

Reinforcement Type and Loading Condition		Resistance Factor	
Metallic reinforcement and connectors	Strip reinforcements ^(A)		
		Static loading	0.75
		Combined static/earthquake loading	1.00
		Combined static/traffic barrier impact ^(B)	1.00
	Grid reinforcements ^(A, C)		
		Static loading	0.65
		Combined static/earthquake loading	0.85
		Combined static/traffic barrier impact ^(B)	0.85
	Geosynthetic reinforcement and connectors		Static loading
		Combined static/earthquake loading	1.20
		Combined static/traffic barrier impact ^(B)	1.20
Pullout resistance of tensile reinforcement (metallic and geosynthetic)		Static loading	0.90
		Combined static/earthquake loading	1.20
		Combined static/traffic barrier impact ^(B)	1.00
Notes:			
A. Apply to gross cross-section less sacrificial area. For sections with holes, reduce gross area in accordance with AASHTO (2007) Article 6.8.3 and apply to net section less sacrificial area.			
B. Combined static/traffic barrier impact resistance factors are not presented in AASHTO.			
C. Applies to grid reinforcements connected to rigid facing element, e.g., a concrete panel or block. For grid reinforcements connected to a flexible facing mat or which are continuous with the facing mat, use the resistance factor for strip reinforcements.			

4.4.7.g Select Grade of and/or Number of Soil Reinforcement Elements at Each Level

The soil reinforcement vertical layout, the factored tensile force at each reinforcement level, and the factored soil reinforcement resistance were defined in the previous three steps. With this information, select suitable grades (strength) of reinforcement, or number of discrete (e.g., strip) reinforcements, for the defined vertical reinforcement layout. Then with this layout check pullout and, as applicable, extreme event loadings. Adjust layout if/as necessary.

Stability with respect to breakage of the reinforcements requires that:

$$T_{MAX} \leq T_r \quad (4-34)$$

Where T_{MAX} is the maximum factored load in a reinforcement (Eqs. 4-32) and T_r is the factored reinforcement tensile resistance (Eq. 4-33).

4.4.7.h Internal Stability with Respect to Pullout Failure

Stability with respect to pullout of the reinforcements requires that the factored effective pullout length is greater than or equal to the factored tensile load in the reinforcement, T_{MAX} . Each layer of reinforcement should be checked, as pullout resistance and/or tensile loads may vary with reinforcement layer. Therefore, the following criteria should be satisfied:

$$\phi L_e \geq \frac{T_{MAX}}{F^* \alpha \sigma_v C R_c} \quad (4-35)$$

where:

- L_e = The length of embedment in the resisting zone. Note that the boundary between the resisting and active zones may be modified by concentrated loadings.
- T_{MAX} = Maximum reinforcement tension
- ϕ = Resistance factor for soil reinforcement pullout. See Table 4-7.
- F^* = Pullout resistance factor (see Chapter 3) with variation in depth starting at the same elevation as that for K_r/K_a variation.
- α = Scale correction factor (see Chapter 3)
- σ_v = Nominal (i.e., unfactored) vertical stress at the reinforcement level in the resistant zone, including distributed dead load surcharges, neglecting traffic loads. See Figure 4-15 for computing σ_v for sloping backfills.
- C = 2 for strip, grid, and sheet type reinforcement
- R_c = Coverage ratio

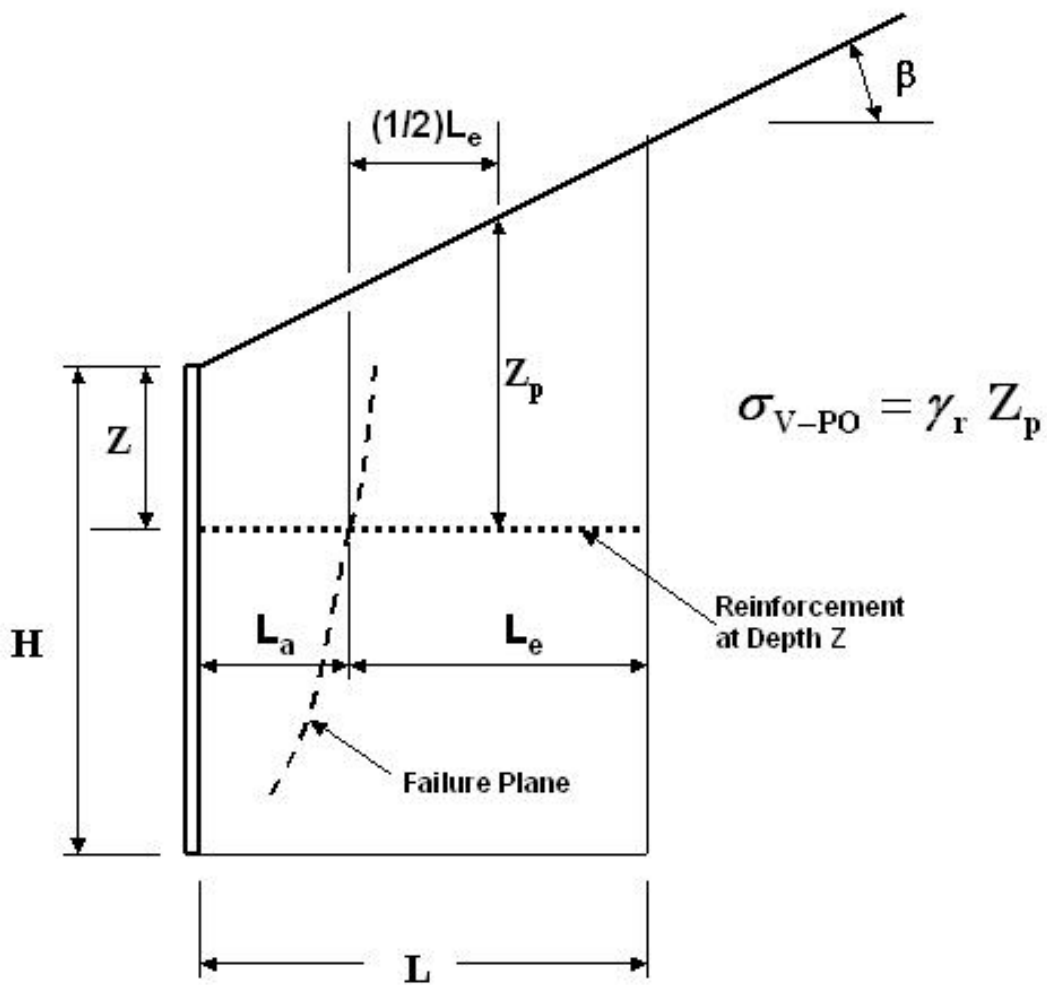

Figure 4-15. Nominal vertical stress at the reinforcement level in the resistant zone, beneath a sloping backfill.

Therefore, the required embedment length in the resistance zone (i.e., beyond the potential failure surface) can be determined from:

$$L_e \geq \frac{T_{MAX}}{\phi F^* \alpha \sigma_v C R_e} \geq 3 \text{ ft (1 m)} \quad (4-36)$$

If a traffic or other live load is present, it is recommended that T_{MAX} be computed with the live loads and that the pullout resistance be computed excluding the live loads. This addresses the possibility of the live loads being present near the front of the wall but not above the reinforcement embedment length. The pullout resistance and the T_{MAX} can be calculated with the live load excluded (AASHTO {2009 Interims} specifications) if it can be shown that the live load will be on the active and resistant zones at the same time or on the resistant zone alone. An agency should note their pullout calculation requirement, if it varies from AASHTO, in their specifications.

Commentary C11.10.6.2.1 (AASHTO, 2009 Interims) notes that traffic loads and other live loads are not included for pullout calculations. Therefore, if T_{MAX} calculation for checking the reinforcement and connection strengths included a live load surcharge the value must be recomputed, without the surcharge load, for Equation 4-35 or 4-36.

If the criterion is not satisfied for all reinforcement layers, the reinforcement length has to be increased and/or reinforcement with a greater pullout resistance per unit width must be used, or the reinforcement vertical spacing may be reduced which would reduce T_{MAX} .

The total length of reinforcement, L , required for internal stability is then determined from:

$$L = L_a + L_e \quad (4-37)$$

where L_a is obtained from Figure 4-9 for simple structures not supporting concentrated external loads such as bridge abutments. Based on this figure the following relationships can be obtained for L_a :

For MSE walls with **extensible** reinforcement, vertical face and horizontal backfill:

$$L_a = (H - Z) \tan (45 - \phi'/2) \quad (4-38)$$

where Z is the depth to the reinforcement level.

For walls with **inextensible** reinforcement, vertical face and horizontal backfill, from the base up to H/2:

$$L_a = 0.6 (H-Z) \quad (4-39)$$

For the upper half of a wall with inextensible reinforcements, vertical face, and horizontal backfill:

$$L_a = 0.3H \quad (4-40)$$

For construction ease, a final uniform length is commonly chosen, based on the maximum length required. However, if internal stability controls the length, it could be varied from the base, increasing with the height of the wall to the maximum length requirement based on a combination of internal and maximum external stability requirements. See Chapter 6, section 6.3 for additional guidance.

4.4.7.i Check Connection Strength

The connection of the reinforcements with the facing, should be designed for T_{MAX} for all limit states. The resistance factors (ϕ) for the connectors are the same as for the reinforcement strength, and are listed in Table 4-7 (Article 11.10.6.2.2 (AASHTO, 2007)).

Connections to Concrete Panels

The metallic reinforcements for MSE systems constructed with segmental precast panels are structurally connected to the facing by either bolting the reinforcement to a tie strip cast in the panel or connected with a bar connector to suitable anchorage devices in the panels. The capacity of the embedded connector as an anchorage must be checked by tests as required by Article 5.11.3 AASHTO (2007) for each geometry used. Connections between metallic reinforcements and facing units should be designed in accordance with AASHTO Article 6.13.3, and consider corrosion losses in accordance with AASHTO Article 11.10.6.4.2a. The design load at the connection is equal to the maximum load on the reinforcement.

Polyethylene geogrid reinforcements may be structurally connected to segmental precast panels by casting a tab of the geogrid into the panel and connecting to the full length of geogrid with a *bodkin* joint, as illustrated in Figure 4-16. The capacity of the embedded connector as an anchorage must be checked by tests as required by Article 5.11.3 AASHTO (2007) for each geometry used. A slat of polyethylene is used for the bodkin. Care should be exercised during construction to eliminate slack from this connection.

Polyester geogrids and geotextiles should not be cast into concrete for connections, due to potential chemical degradation. Other types of geotextiles also are not cast into concrete for connections due to fabrication and field connection requirements.

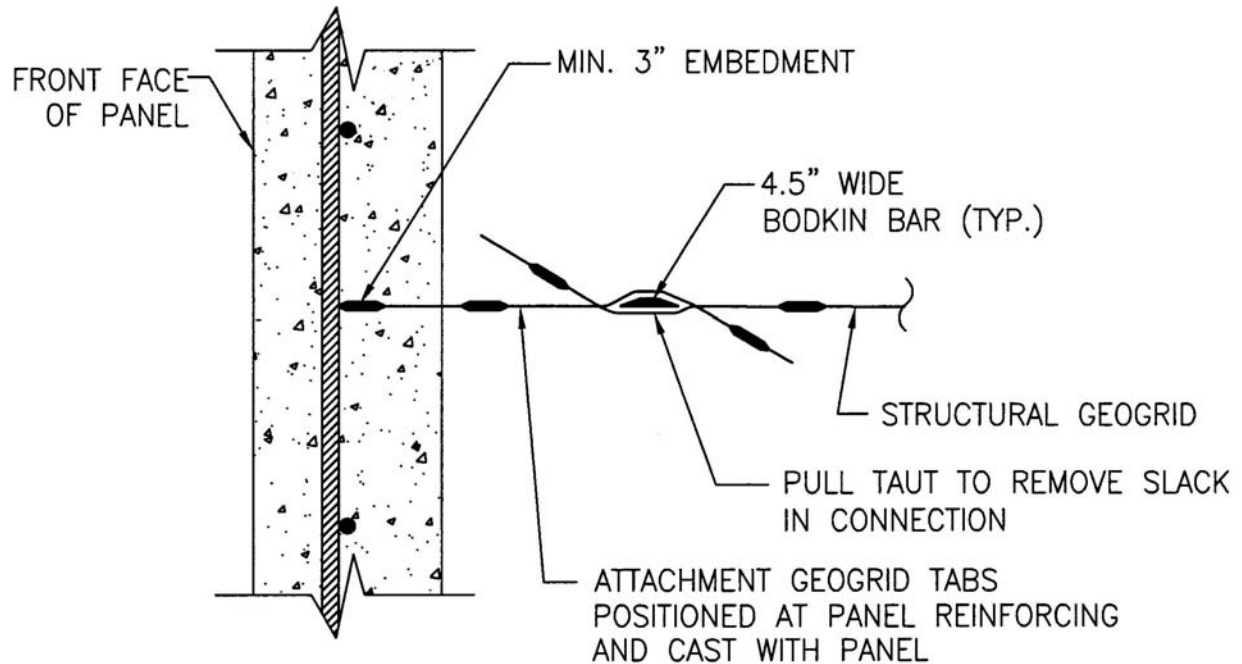

Figure 4-16. Bodkin connection detail (looking at cross section of segmental panel face).

Connections to MBW Units

MSE walls constructed with MBW units are connected either by (i) a structural connection subject to verification under AASHTO Article 5.11.3, (ii) friction between the units and the reinforcement, including the friction developed from the aggregate contained within the core of the units, or, (iii) a combination of friction and shear from connection devices. This strength will vary with each unit depending on its geometry, unit batter, normal pressure, depth of unit, and unit infill gravel (if applicable). The connection strength is therefore specific to each unit/reinforcement combination and must be developed uniquely by test for each combination.

The nominal long-term connection strength, T_{alc} developed by frictional and/or structural means is determined as follows:

$$T_{alc} = \frac{T_{ult} \times CR_{cr}}{RF_D} \quad (4-41)$$

where:

- T_{alc} = nominal long-term reinforcement/facing connection strength per unit reinforcement width at a specified confining pressure
- T_{ult} = ultimate tensile strength of the geosynthetic soil reinforcement, defined as the minimum average roll value (MARV)
- RF_D = reduction factor to account for chemical and biological degradation
- CR_{cr} = long-term connection strength reduction factor to account for reduced ultimate strength resulting from the connection

CR_{cr} may be obtained from long-term or short-term tests, as described below.

CR_{cr} Defined with Long-Term Testing

A series of connection creep tests are performed over extended periods of time to evaluate creep rupture at the connection. The long-term connection creep rupture data is extrapolated to the specified design life (e.g., 75 years, 100 years) to define the creep reduced connection strength, T_{crc} , at the specified design life. Details for long-term testing and interpretation of results are presented in Appendix B. With this long-term testing, CR_{cr} is defined as follows:

$$CR_{cr} = \frac{T_{crc}}{T_{lot}} \quad (4-42)$$

T_{lot} is the ultimate wide width tensile strength of the reinforcement material roll/lot used for the connection strength testing. The T_{lot} strength, for example, might be 103% to 115% of the minimum average roll value (MARV) ultimate strength, T_{ult} (or noted $T_{ult-MARV}$).

CR_{cr} Defined with Short-Term Testing

Short-term (i.e., quick) ultimate strength tests, per ASTM D6638, are used to define an ultimate connection strength, $T_{ultconn}$, at a specified confining pressure. Tests should be performed in accordance with ASTM D6638, *Determining Connection*

Strength Between Geosynthetic Reinforcement and Segmental Concrete Units (Modular Concrete Blocks). With short-term testing, CR_{cr} , is defined as follows:

$$CR_{cr} = \frac{T_{ultconn}}{RF_{cr} T_{lot}} \quad (4-43)$$

RF_{cr} is the geosynthetic creep reduction factor (see Chapter 3), and T_{lot} is the ultimate wide width tensile strength of the reinforcement material roll/lot used for the connection strength testing.

Raw data from short-term connection strength laboratory testing should not be used for design. The wall designer should evaluate the data and define the nominal long-term connection strength, T_{alc} . Steps for this data reduction are summarized and discussed in Appendix B. An example of reduction of short-term connection strength data is presented in Appendix B.

Note that the environment between and directly behind the modular blocks at the connection may not be the same as the environment within the reinforced soil zone. Therefore, the long-term environmental aging factor (RF_D) may be significantly different than that used in computing the nominal long-term reinforcement strength T_{al} .

The connection strength as developed above is a function of normal pressure, which is developed by the weight of the units. Thus, it will vary from a minimum in the upper portion of the structure to a maximum near the bottom of the structure for walls with no batter. Further, since many MBW walls are constructed with a front batter, the column weight above the base of the wall or above any other interface may not correspond to the weight of the facing units above the reference elevation. The concept is shown in Figure 4-17, and is termed a hinge height (Simac et al., 1993). Hence, for walls with a nominal batter of more than 8 degrees, the normal stress is limited to the lesser of the hinge height or the height of the wall above the interface. This vertical pressure range should be used in developing CR_{cr} . This recommendation is based on research findings that indicated that the hinge height concept is overly conservative for walls with small batters (Bathurst et al., 2000).

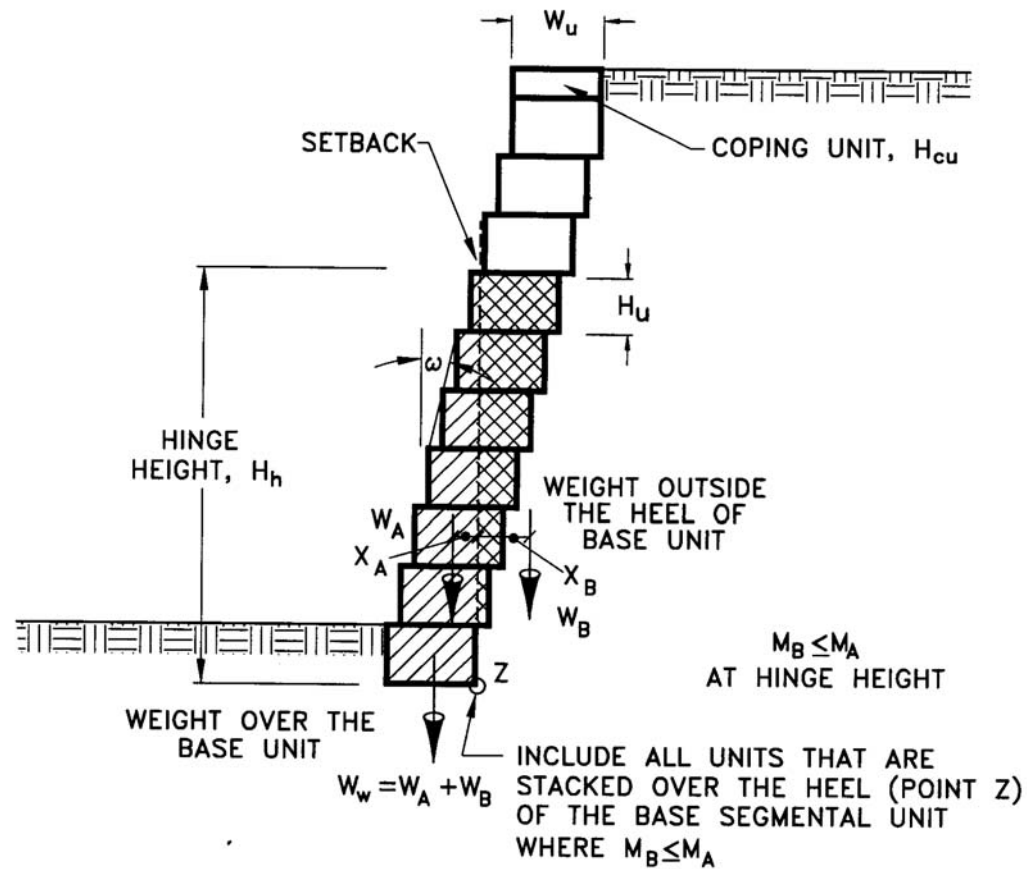

HINGE HEIGHT, H_h . THE FULL WEIGHT OF ALL SRW UNITS WITHIN H_h WILL BE CONSIDERED TO ACT AT THE BASE OF THE LOWERMOST SRW UNIT.

$$M_A = W_A * X_A$$

$$M_B = W_B * X_B$$

$$H_h = 2(W_u - G_u) / \tan \omega$$

where:

- H_u = SRW unit height (ft)
- W_u = SRW unit width, front to back (ft)
- G_u = distance to the center of gravity of a horizontal SRW unit including aggregate fill, measured from the front of the unit (ft)
- ω = wall batter due to setback per course (deg)
- H = total height of wall (ft)
- H_h = hinge height (ft)

Figure 4-17. Determination of hinge height for modular concrete block faced MSE walls (NMCA, 1997).

4.4.7.j Lateral Movements

The evaluation of lateral wall movements in LRFD is the same as in ASD as the deformations are evaluated at the Service I limit state. In general, most internal lateral deformations of an MSE wall face usually occur during construction. Post construction movements, however, may take place due to post construction surcharge loads, settlement of wall fill, or long-term settlement of the foundation soils.

The magnitude of lateral displacement depends on fill placement techniques, compaction effects, reinforcement extensibility, reinforcement length, reinforcement-to-facing connection details, and details of the wall facing. The rough estimate of probable lateral displacements of simple MSE walls that may occur during construction can be estimated based on empirical correlations (see Figure 2-15). In general, increasing the length-to-height ratio of reinforcement, from its theoretical lower limit of $0.5H$ to the AASHTO specified $0.7H$, decreases the deformation by about 50 percent. For critical structures requiring precise tolerances, such as bridge abutments, more accurate calculations using numerical modeling may be warranted.

A deformation response analysis allows for an evaluation of the anticipated performance of the structure with respect to horizontal (and vertical) displacement. Horizontal deformation analyses are the most difficult and least certain of the performed analyses. In many cases, they are done only approximately. The results may impact the choice of facing, facing connections, or backfilling sequences.

4.4.7.k Vertical Movement and Bearing Pads

Bearing pads are placed in horizontal joints of segmental precast concrete panels in order to allow the panel and the reinforcement to move down with the reinforced fill as it is placed and settles, mitigate downdrag stress, and provide flexibility for differential foundation settlements. Internal settlement within the reinforced fill is practically immediate with some minor movement occurring after construction due to elastic compression in granular materials. The amount of total movement is the combination of the internal movement and external differential movement. The bearing/compression pad thickness and compressibility could be adjusted according to the anticipated movement. Otherwise concrete panel cracking and/or downdrag on connections resulting in bending of connections and/or out of plane panel movement can occur. Calculation of the external settlement was reviewed in Section 4.4.6.d. Normally the internal movement is negligible for well graded, granular fill and external movement will usually control the compression pad requirements as listed in Table 2-3. However, when using sand type fill and/or marginal fill containing an appreciable amount of fines, the internal movement can be significant and should be calculated to evaluate additional thickness requirements of the bearing pad. Immediate settlement of

granular fill can be calculated using the Schmertmann method, as described in the FHWA NHI-06-088 and NHI-06-089, *Soils and Foundation Reference* manuals (Samtani and Nowatzki, 2006).

The stiffness (axial and lateral), size, and number of bearing pads should be sized such that the final joint opening will be at least $\frac{3}{4} \pm 1/8$ -inch, unless otherwise shown on the plans. As noted in Chapter 2, a minimum initial joint width of $\frac{3}{4}$ -inch is recommended. The stiffness (axial and lateral), size, and number of bearing pads are should be checked assuming a vertical loading at a given joint equal to 2 to 3 times the weight of facing panels directly above that level. Laboratory tests in the form of vertical load-vertical strain and vertical load-lateral strain curves of the bearing pads are required for this check.

4.4.8 Step 8 – Design of Facing Elements

4.4.8.a Design of Concrete, Steel and Timber Facings

Facing elements are designed to resist the horizontal forces developed in Section 4.3. Reinforcement is provided to resist the maximum loading conditions at each depth in accordance with structural design requirements in Section 5, 6 and 8 of AASHTO (2007) for concrete, steel and timber facings, respectively. The embedment of the soil reinforcement to panel connector must be developed by test, to ensure that it can resist the T_{MAX} loads.

As a minimum, temperature and shrinkage steel must be provided for segmental precast panel facing. Epoxy protection of panel reinforcement or a minimum of 3 in. (75 mm) of concrete cover is recommended where salt spray is anticipated.

For modular concrete facing blocks (MBW), sufficient inter-unit shear capacity must be available, and the maximum spacing between reinforcement layers should be limited to twice the front to back width, W_u , as defined in Figure 4-17, of the modular concrete facing unit or 2.7 ft (32 in., 800 mm) whichever is less. The maximum depth of facing below the bottom reinforcement layer should typically be limited to the width, W_u (see Figure 4-17), of the modular concrete facing unit used. The top row of reinforcement should be limited to 1.5 the block depth (e.g. one unit plus a cap unit) (AASHTO 11.10.2.3.1 {2007}).

The factored inter-unit shear capacity as obtained by testing (ASTM D6916) at the appropriate normal load should exceed the factored horizontal earth pressure at the facing.

For seismic performance Zones 3 or 4, facing connections in modular block faced walls (MBW) should use shear resisting devices between the MBW units and soil reinforcement, and should not be fully dependent on frictional resistance between the soil reinforcement and

facing blocks. Shear resisting devices between the facing blocks and soil reinforcement such as shear keys, pins, etc. should be used. For connections partially or fully dependent on friction between the facing blocks and the soil reinforcement, the nominal long-term connection strength T_{ac} , should be reduced to 80 percent of its static value. Further, the blocks above the uppermost layer of soil reinforcement must be secured against toppling under all seismic events.

4.4.8.b Design of Flexible Wall Facings

Welded wire or similar facing panels should be designed in a manner which prevents the occurrence of excessive bulging as backfill behind the facing elements compresses due to compaction stresses, self weight of the backfill or lack of section modulus. Bulging at the face between soil reinforcement elements in both the horizontal and vertical direction generally should be limited to 1 to 2 in. (25 to 50 mm) as measured from the theoretical wall line. Specification requirements and design detailing to help achieve this tolerance might include limiting the face panel height to 18 in. (460 mm) or less, the placement of a nominal 2 ft (0.6 m) wide zone of rockfill or cobbles directly behind the facing, decreasing the vertical and horizontal spacing between reinforcements, increasing the section modulus of the facing material, and/or by providing sufficient overlap between adjacent facing panels. Furthermore, the top of the flexible facing panel at the top of the wall should be attached to a soil reinforcement layer to provide stability to the top of the facing panel.

Geosynthetic facing elements generally should not be left exposed to sunlight (specifically ultraviolet radiation) for permanent walls. If geosynthetic facing elements must be left exposed permanently to sunlight, the geosynthetic should be stabilized to be resistant to ultraviolet radiation. Furthermore, product specific test data should be provided which can be extrapolated to the intended design life and which proves that the product will be capable of performing as intended in an exposed environment. Alternately a protective facing should be constructed in addition (e.g., concrete, shotcrete, etc.).

4.4.9 Step 9 – Assess Overall/Global Stability

This design step is performed to check the overall, or global, stability of the wall. Overall stability is determined using rotational or wedge analyses, as appropriate, to examine potential failure planes passing behind and under the reinforced zone. Analyses can be performed using a classical slope stability analysis method with standard slope stability computer programs. In this step, the reinforced soil wall is considered analogous to a rigid body and only failure surfaces completely outside a reinforced zone (e.g., global failure planes) are considered. Computer programs that directly incorporate reinforcement elements

(e.g., ReSSA) can be used for analyses that investigate both global and *compound* failure planes. See Section 4.4.10 for failure planes that pass partially through the reinforced zone.

Per Article 11.6.2.3 AASHTO (2007), the evaluation of overall stability of MSE walls should be investigated at the Service I Load Combination, and using an appropriate resistance factor. Commonly used slope stability programs can be used to conduct this evaluation. The load factor at Service I limit state is 1.0 for permanent loads. In lieu of better information, the soil shear resistance factor (ϕ) is defined in Article 11.6.2.3 (AASHTO, 2007) as:

$\phi = 0.75$; where the geotechnical parameters are well defined, and the slope does not support or contain a structural element; and

$\phi = 0.65$; where the geotechnical parameters are based on limited information, or the slope contains or supports a structural element

The intent of the term “structural element” is that a resistance factor of 0.65 should be used for slope stability analysis if the slope/wall supports a bridge foundation, a building, or similar structure foundation that cannot tolerate significant movement or if the consequences of the failure of the supported structure are severe. A resistance factor of 0.75 may be more appropriate for slopes/walls that support structures such as a sign foundation where movements may not be detrimental or the consequences of the failure are not significant. The Agency/Owner should define whether the MSE wall structure itself is classified as a significant “structural element” (i.e., consequences of failure are severe) and a resistance factor of 0.65 is applicable, or if it is a minor structure and a resistance factor of 0.75 is applicable. (Also note that a slope supporting a structural element should have well defined geotechnical parameters.)

The codification of LRFD load and resistance factors by probabilistic calibrations for the design of slopes are currently being research and developed. Commercial slope stability analysis programs fully compatible with AASHTO LRFD procedures are not readily available. Therefore, designs today might be performed by traditional (non-LRFD) methods and with existing slope stability programs, and a comparison of computed safety factor to target resistance factor.

The AASHTO (2007) stated resistance factors of 0.75 and 0.65 are (generally) approximately equivalent to the safety factors of 1.3 and 1.5, respectively, that is:

$$\phi = 0.75 \Rightarrow \frac{1}{0.75} \approx 1.3 = FS \quad \text{and} \quad \phi = 0.65 \Rightarrow \frac{1}{0.65} \approx 1.5 = FS$$

Note that AASHTO resistance factors are stated to the nearest 0.05, so as to not overstate the level of accuracy of a resistance value. Therefore, if assessing global stability with limit equilibrium slope stability methods, the target safety factors are:

FS = 1.30 where the geotechnical parameters are well defined;

FS = 1.50 where the geotechnical parameters are based on limited information; and

FS = 1.50 where the wall/slope contains or supports a structural element.

This is consistent with past practice, per FHWA NHI-00-043 (Elias et al., 2001).

The evaluation of overall stability should be performed with reasonable estimates of short- and long-term water pressures (a geotechnical parameter) acting on the wall. If the evaluation of overall stability does not indicate a satisfactory result then the reinforcement length may have to be increased or the foundation soil may have to be improved. The design must be revised according to these changes.

Most agencies typically perform global stability assessments for MSE walls. Global stability generally is assessed by the agency during feasibility design, which might result in ground improvement or other wall options, and again after the wall is designed. The MSE wall vendors/suppliers typically exclude overall stability check and responsibility in their package unless contract documents require such an evaluation by the wall vendor/supplier.

4.4.10 Step 10 – Assess Compound Stability

Additional slope stability analyses should be performed for MSE walls to investigate potential *compound* failure surfaces, i.e., failure planes that pass behind or under and through a portion of the reinforced soil zone as illustrated in Figure 4-18. For simple structures with rectangular geometry, relatively uniform reinforcement spacing, and a near vertical face, compound failures passing both through the unreinforced and reinforced zones will not generally be critical. **However, if complex conditions exist such as changes in reinforced soil types or reinforcement lengths, high surcharge loads, seismic loading, sloping faced structures, significant slopes at the toe or above the wall, or stacked (tiered) structures, compound failures must be considered.**

This design step is performed to check potential compound failure planes passing through the reinforced soil zone. Compound stability is determined using rotational or wedge analyses, as appropriate, performed with computer programs that directly incorporate reinforcement elements (e.g., ReSSA) in the analyses. The reinforced soil wall is not considered a rigid body and is modeled with appropriate soil properties and the soil reinforcement layers as discrete elements. The long-term strength of each reinforcement layer intersected by the

failure surface should be considered as resisting forces in the limit equilibrium slope stability analysis. The facing system should be modeled with separate, but appropriate strength properties.

Proposed Procedure: Current AASHTO (2007) states that compound stability should be investigated. However, procedures (i.e., load and resistance factors) are not specifically defined. The recommended procedure is to follow global stability procedures and include reinforcement strength.

If assessing compound stability with limit equilibrium slope stability methods (e.g., modified Bishop, Spencer, etc.) a load factor of 1.0 should be used. Compound analyses should use the same AASHTO (2007) stated global stability resistance factors (ϕ) of 0.75 and 0.65. These resistance factors are approximately equivalent to safety factors of 1.3 and 1.5, respectively, as previously noted.

Therefore, if assessing compound stability with limit equilibrium slope stability methods, the target safety factors with limit equilibrium analysis are:

FS = 1.30 where the geotechnical parameters are well defined;

FS = 1.50 where the geotechnical parameters are based on limited information; and

FS = 1.50 where the wall/slope contains or supports a structural element

This is consistent with past practice, per FHWA NHI-00-043 (Elias et al., 2001).

Note, however, that the method of incorporating the soil reinforcement strength into the stability calculations does affect the magnitude of factor of safety computed. See Section 9.3 for recommendations on how reinforcement strength should be incorporated.

The evaluation of compound stability should be performed with reasonable estimates of short- and long-term water pressures. If the evaluation of compound stability does not indicate a satisfactory result then the reinforcement length, reinforcement strength, reinforcement vertical spacing, and/or depth of wall may have to be increased, or the foundation soil may have to be improved. The design must be revised according to these changes, and compound stability rechecked as appropriate.

Compound stability analyses require detailed information on both the subsurface conditions (typically defined by the agency) and the soil reinforcement layout (typically vendor defined). Unlike global stability analyses, the responsibility for this analysis is not clearly defined. Agencies should perform an initial assessment of a proposed MSE wall structure with an assumed reinforcement layout to determine if compound stability is a concern and

must be addressed in final design. Typical geometries where compound stability is of concern are illustrated in Figure 4-18. Generally, MSE wall vendors/suppliers exclude compound stability check and responsibility in their package, unless specifically required by the Owner.

Compound stability can be addressed by selecting one of the following three options for specifying and bidding the MSE wall (Schwanz et al., 1997):

1. Agency Design. Agency prepares complete design for the MSE wall including external, internal, global, and compound stability analyses. This requires material specifications for all wall components.
2. Vendor Design. Agency prepares line and grade plans, and allows approved vendors to supply the complete design and wall components. Agency is responsible for and must provide detailed subsurface profile(s), soil shear strength, soil unit weight, and groundwater information for the vendor to use in external, global, and compound stability analyses. Agency should perform a feasibility analysis to ensure global stability can be achieved with the line and grade provided to the vendors.
3. Combined Design. Agency prepares line and grade plans, assesses global and compound stability requirements, and specifies/detail reinforcement requirements for adequate stability resistance. For example, the agency might specify two layers of reinforcement within a range of elevations (at bottom of wall) with minimum strength and minimum lengths required. Wall vendor completes wall design with incorporation of reinforcement required for adequate compound stability resistance.

Applications of the above three options by the St. Paul District of the U.S. Army Corps of Engineers are summarized by Schwanz et al. (1997). Advantages and disadvantages with each option are discussed in the cited reference.

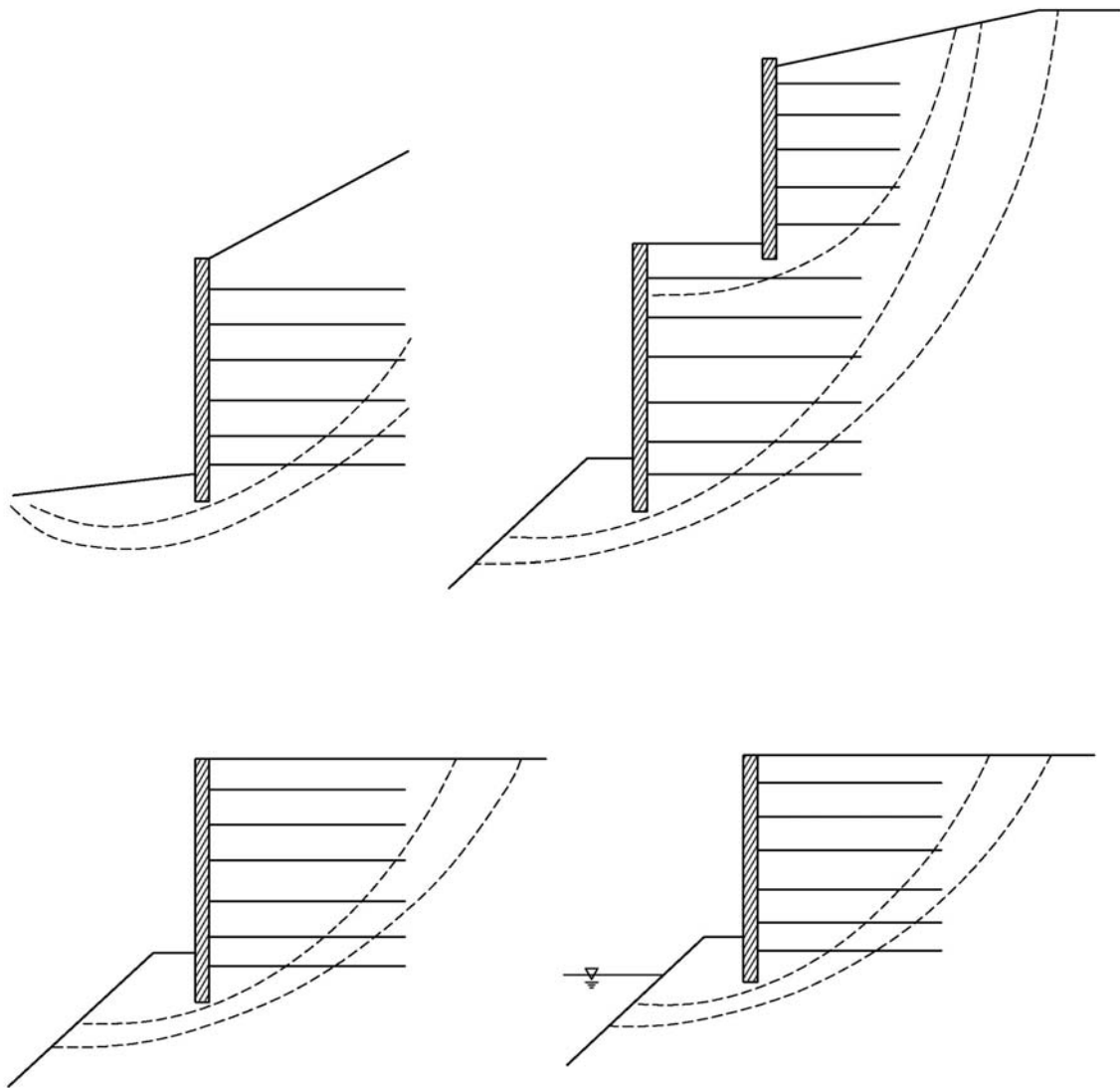

Figure 4-18. Typical geometries where MSE wall compound stability is of concern: steep and tall backslope on top of the wall; tiered walls; slope at the toe of the wall; and water at toe of the slope.

4.4.11 Step 11 – Wall Drainage Systems

Drainage is a very important aspect in the design and specifying of MSE walls. The Agency should detail and specify drainage requirements for vendor designed walls. Furthermore, the Agency should coordinate the drainage design and detailing (e.g., outlets) within its own designers and with the vendor. The Agency is also responsible for long-term maintenance of drainage features, as discussed in Section 5.3.4.

4.4.11.a Subsurface Drainage

Subsurface drainage must be addressed in design. The primary component of an MSE wall is soil. Water has a profound effect on this primary component of soil, as it can both decrease the soil shear strength (i.e., resistance) and increase destabilizing forces (i.e., load). Thus, FHWA recommends drainage features be required in all walls unless the engineer determines such feature is, or features are, not required for a specific project or structure.

Drainage design and detailing are addressed in Section 5.3. Note that MSE walls using free draining reinforced fill do not typically need a full drainage system, but do need a method for discharging water collected within the reinforced wall fill. Also note that MSE walls can be designed for water loads, if needed. Basic soil mechanics principles should be used to determine the effect of phreatic surface on wall loads. See discussion in Chapter 7 for design of MSE walls for flood and scour events.

4.4.11.b Surface Water Runoff

Surface drainage is an important aspect of ensuring wall performance and must be addressed during design and during construction. Appropriate drainage measures to prevent surface water from infiltrating into the wall fill should be included in the design of a MSE wall structure. Surface drainage design and detailing are addressed in Section 5.3.

4.4.11.c Scour

There are additional detailing considerations for walls that are exposed to potential scour. The wall embedment depth must be below the Agency predicted scour depth. Wall initiation and termination detailing should consider and be design to protect from scour. Riprap may be used to protect the base and ends of a wall. A coarse stone wall fill may desired to drain rapidly. The reinforced wall fill at the bottom of the structure may be wrapped with a geotextile filter to minimize loss of fill should scour exceed design predictions. These items are discussed in detail in Chapter 5.

4.5 TEMPORARY WALLS

Temporary walls are normally considered wall structures with a 36 month or less service life (Article 11.5.1 {AASHTO, 2007}). The design method remains the same as for permanent walls, except for the calculation of the soil reinforcement long-term nominal strength, T_{al} . Metallic soil reinforcements are not normally galvanized for temporary walls. An exception might be when aggressive wall fill materials are being used and galvanization is specified to provide corrosion resistance.

The long-term nominal strength for black steel (i.e., non-galvanized) in non-aggressive reinforced fill soil may be calculated with the whole steel cross-section for temporary walls. The long-term nominal strength for black steel (i.e., non-galvanized) and non-aggressive wall fill soil may be calculated with a corrosion rate of 1.1 mils/yr (28 $\mu\text{m}/\text{yr}$) (FHWA NHI-09-087 {Elias et al., 2009}). Higher corrosion rates need to be considered for reinforced fills that are moderately aggressive or corrosive, and a corrosion specialist should be consulted to assess the sacrificial steel requirements or other possible corrosion protection measures. Steel reinforcement should be galvanized if a service life greater than 36 months is required for a temporary structure.

For geosynthetic soil reinforcements, the long-term nominal strength may be calculated with a minimum durability reduction factor of 1.0 in lieu of 1.1 minimum used for permanent walls. This is for temporary walls and for geosynthetics that meet the minimum requirements listed in Table 3-12.

4.6 DESIGN CHECKLIST

Agencies should have an established, or should establish a, protocol for checking designs. This is particularly important for vendor supplied designs, but should also be used with in-house designs. The protocol should assign responsibilities for the review and list items that should be checked. Thus, the protocol can be in the form of a checklist.

Based upon work by the Arizona Department of Transportation (ADOT), an example design checklist follows. This example may be used by agencies to develop their own checklist with their defined responsibilities and references to the agency's standard specifications, standard provisions, etc. Some of the items on the following checklist are project specific, and others are project and wall structure specific.

MSE WALLS - DESIGN REVIEW EXAMPLE CHECKLIST

TO BE FILLED BY RESIDENT ENGINEER

Project (Name, Contract No., etc.)	
Resident Engineer (RE)	
Date MSE submittal received	
Is this a re-submittal? If yes, attach previous checklist	
Name of Engineer of Record (ER)	
Date submittal transmitted to ER	
Date comments due back to RE	

<i>TO BE FILLED BY ER</i>	REVIEWED BY				
	Materials Group Due Date**	Date Received	Date Reviewed	Name	Organization
Professional Engineer of Record*(ER)					
Date completed checklist sent to RE					
* Contact designated agency Design Engineer immediately upon receipt of the submittal(s) from RE.					
** Due date for submittal to Design Engineer.					

<p>This checklist has been completed under the supervision of the Professional Engineer of Record whose seal and signature appears hereon.</p>	
---	--

LEGEND FOR ABBREVIATIONS / ACRONYMS

AASHTO	American Association of State Highway and Transportation Officials
DE	Agency Design Engineer from assigned to the project.
APL	Approved Products List (For latest APL visit _____).
ER	Engineer of Record (Registered Professional Engineer in the state)
FHWA	Federal Highway Administration
MBW	Modular Block Wall
MSE	Mechanically Stabilized Earth
MSEW 3.0	Version 3.0 of proprietary software, MSEW, by ADAMA Engineering (visit www.geoprograms.com)
NA	Not Applicable
NHI	National Highway Institute
PE	Professional Engineer of Record (shall be a Registered Professional Engineer)
PGR	Project Geotechnical Report
Project Drawings	Complete final plan set for the project
RE	Resident Engineer
Section #, Figure # or Table #	This refers to an appropriate section, figure or table in the following manual by FHWA/NHI: “Design and Construction of Mechanically Stabilized Earth Walls and Reinforced Soil Slopes,” Publication No. FHWA NHI-10-024 Vol I and NHI-10-025 Vol II, (Authors: Ryan R. Berg, Barry R. Christopher and Naresh C. Samtani)
Spec	Project specification including standard specification and special provisions
_____	_____ Department of Transportation
Vendor Drawings	Working drawings provided by MSE wall vendor

All symbols used within the questions are consistent with those used in the documents in the “Reference” column

NOTES FOR CHECKLIST

1. The following information/material should be collected before starting the checklist:
 - a. Contractor submittals (transmittal letter, design drawings, design calculations)
 - b. Project documents (final plan set, standard specifications, special provisions, Project Geotechnical Report)
 - c. FHWA/NHI manual (“Mechanically Stabilized Earth Walls and Reinforced Soil Slopes,” Publication Nos. FHWA NHI-10-024 Vol I and NHI-10-025 Vol II, December 2009; Authors: Ryan R. Berg, Barry R. Christopher and Naresh C. Samtani)
 - d. Latest version of AASHTO LRFD Bridge Design Specifications, including interims
 - e. All due dates for checklist
 - f. Name of the structural engineer
 - g. Name of the roadway engineer
 - h. Name of “prime” designer
2. Each question must have a “Yes”, “No” or “NA” box checked. Any comment or action required should be entered in the “Comments/Action Required” column. If the “No” or “NA” box is checked then an appropriate comment or action required must be entered. Use separate sheets if comments cannot be fitted in the space within the checklist.
3. The documents listed under the “Reference” column in the checklist are not intended to be a complete list of documents. Rather, the most common documents are listed where guidance/information related to the question in the checklist may be found. More stringent criteria may exist in other project documents (e.g., drainage, signage, utilities, etc.) that may be relevant to a given question. In such an event, the governing document should be noted in the “Comments/Action Required” column of the checklist.
4. Add any pertinent project specific questions to the checklist as necessary. Two empty rows are provided at end of each section for this purpose. Use additional sheets as necessary if more space is required.
5. This checklist is intended to be completed, signed, and sealed by the Engineer of Record who is Registered Professional Engineer in the state.
6. The Engineer of Record should contact the project structural or roadway engineer in case of discrepancies between the contractor submittals and reference documents.
7. Wall details that were reviewed and approved as part of the “Approved Products List” will be available on a website; contact the _____ for further information.
8. After completing the checklist the ER should include an attachment that identifies specific questions that the MSE wall vendor (or in-house designer) has to address.

		Reference (See Note 3)	Yes	No	NA	Comments/ Action Required
I. GENERAL INFORMATION						
1.	Is the wall vendor pre-approved? (visit _____ for a list of pre-approved wall systems)	APL	<input type="checkbox"/>	<input type="checkbox"/>	<input type="checkbox"/>	
2.	Is the wall within the limitations of the pre-approved product? (e.g., wall height, external loading, environmental constraints, seismic loading and other project specific constraints; visit _____ for limitations)	APL	<input type="checkbox"/>	<input type="checkbox"/>	<input type="checkbox"/>	
3.	Has the Contractor used the correct design survey data (e.g., existing ground elevations and horizontal offsets) for wall design?	Project/vendor drawings	<input type="checkbox"/>	<input type="checkbox"/>	<input type="checkbox"/>	
4.	Has the Contractor correctly reflected the location of utilities in the area of the wall(s)?	Project/vendor Drawings	<input type="checkbox"/>	<input type="checkbox"/>	<input type="checkbox"/>	
5.	Is the wall profile (top and bottom elevations) including start and end stations correct?	Project/vendor Drawings	<input type="checkbox"/>	<input type="checkbox"/>	<input type="checkbox"/>	
6.	Is the wall design life specified?	Spec/ Section 2.8	<input type="checkbox"/>	<input type="checkbox"/>	<input type="checkbox"/>	
7.	Have the following items been specified by the vendor and are they in conformance with the project requirements?					
	a. Material requirements					
	i. Soil Properties (strength, gradation, PI, soundness, electrochemical)	Spec	<input type="checkbox"/>	<input type="checkbox"/>	<input type="checkbox"/>	
	ii. Soil Reinforcement (ultimate and yield tensile strengths, reduction factors for geosynthetics)	Spec	<input type="checkbox"/>	<input type="checkbox"/>	<input type="checkbox"/>	
	iii. Concrete (strength and other properties)	Spec/Project Drawings	<input type="checkbox"/>	<input type="checkbox"/>	<input type="checkbox"/>	
	iv. Concrete reinforcement (type, number and strength)	Spec/Project Drawings	<input type="checkbox"/>	<input type="checkbox"/>	<input type="checkbox"/>	
	v. Leveling Pad (strength)	Spec/Project Drawings	<input type="checkbox"/>	<input type="checkbox"/>	<input type="checkbox"/>	
	vi. Steel facing elements for wire mesh systems (ultimate and yield tensile strengths)	Spec	<input type="checkbox"/>	<input type="checkbox"/>	<input type="checkbox"/>	
	b. Construction procedures including sequence	APL	<input type="checkbox"/>	<input type="checkbox"/>	<input type="checkbox"/>	
	c. Soil compaction procedures and restrictions for reinforced fill, retained fill and foundation preparation	APL/spec/ PGR	<input type="checkbox"/>	<input type="checkbox"/>	<input type="checkbox"/>	
	d. Facing alignment tolerances	Spec	<input type="checkbox"/>	<input type="checkbox"/>	<input type="checkbox"/>	

		Reference (See Note 3)	Yes	No	NA	Comments/ Action Required
	e. Acceptance/rejection criteria (tolerances, facing finish, etc.)	Spec	<input type="checkbox"/>	<input type="checkbox"/>	<input type="checkbox"/>	
	f. Corrosion protection systems for soil reinforcement	Spec	<input type="checkbox"/>	<input type="checkbox"/>	<input type="checkbox"/>	
	g. Handling and storage of reinforcements	Spec/APL/ PGR	<input type="checkbox"/>	<input type="checkbox"/>	<input type="checkbox"/>	
8.	Is the initial wall batter during construction specified?	APL	<input type="checkbox"/>	<input type="checkbox"/>	<input type="checkbox"/>	
9.	Are the structural (select) backfill dimensions shown?	Spec	<input type="checkbox"/>	<input type="checkbox"/>	<input type="checkbox"/>	
10.	Are the wall quantities (area of wall, volume of structural fill, etc.) listed in accordance with the pay quantity schedule in the project specifications?	Spec	<input type="checkbox"/>	<input type="checkbox"/>	<input type="checkbox"/>	
11.	Wall installation guide		<input type="checkbox"/>	<input type="checkbox"/>	<input type="checkbox"/>	
	a. Has the proprietary vendor submitted a wall installation guide?	APL	<input type="checkbox"/>	<input type="checkbox"/>	<input type="checkbox"/>	
	b. Does the submitted wall installation guide address site-specific conditions?	PGR/Spec	<input type="checkbox"/>	<input type="checkbox"/>	<input type="checkbox"/>	
12.	Is the Contractor's transmittal letter acceptable? (e.g., does it contain acceptable statements consistent with the submittal?)		<input type="checkbox"/>	<input type="checkbox"/>	<input type="checkbox"/>	
	{add as appropriate, may be agency or project specific}		<input type="checkbox"/>	<input type="checkbox"/>	<input type="checkbox"/>	
	{add as appropriate, may be agency or project specific}		<input type="checkbox"/>	<input type="checkbox"/>	<input type="checkbox"/>	
	II. TOP OF WALL					
1.	Do the top of wall elevations match the roadway design elevations?	Project drawings	<input type="checkbox"/>	<input type="checkbox"/>	<input type="checkbox"/>	
2.	Are top of wall elevations such that they can allow for proper interfacing with barriers, copings, surface ditches, bridge abutments, etc. as shown on the plans?	Project drawings	<input type="checkbox"/>	<input type="checkbox"/>	<input type="checkbox"/>	
	{add as appropriate, may be agency or project specific}		<input type="checkbox"/>	<input type="checkbox"/>	<input type="checkbox"/>	
	{add as appropriate, may be agency or project specific}		<input type="checkbox"/>	<input type="checkbox"/>	<input type="checkbox"/>	
	III. LEVELING PAD (Note: Only lean concrete leveling pads are allowed)					
1.	Are the leveling pad dimensions shown?	Spec	<input type="checkbox"/>	<input type="checkbox"/>	<input type="checkbox"/>	
2.	Does the leveling pad profile satisfy the minimum depth of embedment criteria?	Section 2.8/ PGR/ Project Drawings	<input type="checkbox"/>	<input type="checkbox"/>	<input type="checkbox"/>	
3.	Are the leveling pad elevations such that they allow for transverse and longitudinal	Project drawings	<input type="checkbox"/>	<input type="checkbox"/>	<input type="checkbox"/>	

		Reference (See Note 3)	Yes	No	NA	Comments/ Action Required
	drainage structures shown on the plans?					
4.	Are leveling pad steps such that they can accommodate the bottom row facing unit type and size without cutting and/or splicing of the facing units?	APL/vendor drawings	<input type="checkbox"/>	<input type="checkbox"/>	<input type="checkbox"/>	
	{add as appropriate, may be agency or project specific}		<input type="checkbox"/>	<input type="checkbox"/>	<input type="checkbox"/>	
	{add as appropriate, may be agency or project specific}		<input type="checkbox"/>	<input type="checkbox"/>	<input type="checkbox"/>	
IV.	FACING UNITS AND JOINTS					
1.	Are the facing units from the pre-approved list?	APL	<input type="checkbox"/>	<input type="checkbox"/>	<input type="checkbox"/>	
2.	Do facing units meet the project aesthetic criteria?	Spec/Project Drawings	<input type="checkbox"/>	<input type="checkbox"/>	<input type="checkbox"/>	
3.	Have the material properties of the facing units been specified? (Examples: density, strength, freeze-thaw, etc.)	Section 4.4.8/Spec	<input type="checkbox"/>	<input type="checkbox"/>	<input type="checkbox"/>	
4.	Are the materials properties of the facing units in conformance with the project criteria? (Examples: density, strength, freeze-thaw, etc.)	Section 4.4.8/Spec				
5.	Are the facing units structurally adequate as per the project facing unit structural criteria and/or per AASHTO? (deformation of facing elements including local bending should be within allowable limits)	Section 4.4.8/Spec	<input type="checkbox"/>	<input type="checkbox"/>	<input type="checkbox"/>	
6.	Is the horizontal joint width between facing units in conformance with project criteria?	Section 2.8, Table 2-1	<input type="checkbox"/>	<input type="checkbox"/>	<input type="checkbox"/>	
7.	Does the joint bearing pad material conform to project specifications?	Spec	<input type="checkbox"/>	<input type="checkbox"/>	<input type="checkbox"/>	
8.	Is the joint bearing pad material of proper compressive strength such that facing unit to facing unit crushing and /or high stress concentrations on any facing units are prevented?	Spec/APL	<input type="checkbox"/>	<input type="checkbox"/>	<input type="checkbox"/>	
9.	For Modular Block Wall (MBW) units with geosynthetic soil reinforcement has the hinge height concept been used for establishing connection details?	Section 4.4.7	<input type="checkbox"/>	<input type="checkbox"/>	<input type="checkbox"/>	
	{add as appropriate, may be agency or project specific}		<input type="checkbox"/>	<input type="checkbox"/>	<input type="checkbox"/>	
	{add as appropriate, may be agency or project specific}		<input type="checkbox"/>	<input type="checkbox"/>	<input type="checkbox"/>	

		Reference (See Note 3)	Yes	No	NA	Comments/ Action Required
V. DRAINAGE						
1.	Are all vertical and horizontal joints covered with geotextile fabric on the backside of the wall facing units?	Spec	<input type="checkbox"/>	<input type="checkbox"/>	<input type="checkbox"/>	
2.	Is the geotextile fabric covering the joints of sufficient width and continuous across the joints?	Spec	<input type="checkbox"/>	<input type="checkbox"/>	<input type="checkbox"/>	
3.	Do the geotextile fabric properties (survivability, filtration and permittivity) covering the joints meet project specifications?	Spec	<input type="checkbox"/>	<input type="checkbox"/>	<input type="checkbox"/>	
4.	Has drainage along the backcut been included as per project criteria?	PGR/Spec	<input type="checkbox"/>	<input type="checkbox"/>	<input type="checkbox"/>	
5.	If geocomposite is used for drainage, then is it pre-approved and do its properties (flow capacity, filtration and permeability) meet project requirements?	PGR/APL/ Spec	<input type="checkbox"/>	<input type="checkbox"/>	<input type="checkbox"/>	
6.	Is the water from subsurface drainage adequately led out of the wall system? e.g., collector and drain system with weepholes, grades towards wall ends, etc.	PGR/Spec	<input type="checkbox"/>	<input type="checkbox"/>	<input type="checkbox"/>	
7.	Is surface drainage in accordance with project criteria?	Project Drawings	<input type="checkbox"/>	<input type="checkbox"/>	<input type="checkbox"/>	
8.	If Modular Block Wall (MBW) units are used for facing then has adequate drain fill been provided?	Section 5.35/Figure 5.6/Spec	<input type="checkbox"/>	<input type="checkbox"/>	<input type="checkbox"/>	
	{add as appropriate, may be agency or project specific}		<input type="checkbox"/>	<input type="checkbox"/>	<input type="checkbox"/>	
	{add as appropriate, may be agency or project specific}		<input type="checkbox"/>	<input type="checkbox"/>	<input type="checkbox"/>	
VI. SPECIAL WALL DETAILS						
1.	Are wall interface details with other walls that will be constructed before, during, or after this contract shown?	Spec/ Section 5.5	<input type="checkbox"/>	<input type="checkbox"/>	<input type="checkbox"/>	
2.	Are following special wall details shown and are they adequate?:					
	a. special facing element if interfacing with other wall systems	Spec/APL/ Section 5.5	<input type="checkbox"/>	<input type="checkbox"/>	<input type="checkbox"/>	
	b. slip joint(s) (e.g., at wing walls, differential settlement concerns, etc.)	Spec/APL	<input type="checkbox"/>	<input type="checkbox"/>	<input type="checkbox"/>	
	c. wall end(s)	Spec/APL	<input type="checkbox"/>	<input type="checkbox"/>	<input type="checkbox"/>	
	d. connection to appurtenances (e.g., box inlets and large obstructions)	Spec/APL/ Section 5.5	<input type="checkbox"/>	<input type="checkbox"/>	<input type="checkbox"/>	
	e. acute angles	Spec/APL/ PGR	<input type="checkbox"/>	<input type="checkbox"/>	<input type="checkbox"/>	
	f. coping	Spec/APL/ Section 4.5	<input type="checkbox"/>	<input type="checkbox"/>	<input type="checkbox"/>	

	Reference (See Note 3)	Yes	No	NA	Comments/ Action Required
g. railing, guard rails or traffic barriers	Spec/APL/ Section 5.1	<input type="checkbox"/>	<input type="checkbox"/>	<input type="checkbox"/>	
h. miscellaneous obstructions (e.g., utilities) below ground elevation	Spec/APL/ Section 4.55.4	<input type="checkbox"/>	<input type="checkbox"/>	<input type="checkbox"/>	
i. measures to prevent migration of de-icing salts in the reinforced fill	Spec/APL/ Section 5.3	<input type="checkbox"/>	<input type="checkbox"/>	<input type="checkbox"/>	
j. measures to protect against rapid drawdown conditions and hydrostatic pressures	Spec/APL/ Section 4.55.3	<input type="checkbox"/>	<input type="checkbox"/>	<input type="checkbox"/>	
3. Are structural frames (“yokes”) provided to navigate the bar mat soil reinforcements around vertical obstructions within the MSE backfill? (examples of vertical obstructions include piles, shafts, inlet structures, etc.)	Spec/APL/ Section 4.55.4	<input type="checkbox"/>	<input type="checkbox"/>	<input type="checkbox"/>	
4. Are the structural frames designed properly so that moments and torques are not introduced in the bar mat soil reinforcements and/or the reinforcement/facing unit connection?	APL/ Bridge Group	<input type="checkbox"/>	<input type="checkbox"/>	<input type="checkbox"/>	
5. Is the splay of strip reinforcements limited to less than 15 degrees?	Spec	<input type="checkbox"/>	<input type="checkbox"/>	<input type="checkbox"/>	
6. If strip reinforcements are splayed, then is the length increased to compensate for reduction in effective length?	PGR/Spec	<input type="checkbox"/>	<input type="checkbox"/>	<input type="checkbox"/>	
7. Is the maximum vertical bend (maximum 15 degrees) in metallic soil reinforcements within acceptable limits?	Spec/ Section 5.4	<input type="checkbox"/>	<input type="checkbox"/>	<input type="checkbox"/>	
8. Are geosynthetic reinforcement details around vertical obstructions acceptable?	APL	<input type="checkbox"/>	<input type="checkbox"/>	<input type="checkbox"/>	
9. Are overlapping reinforcements separated vertically by at least 3-in. of soil?	Spec	<input type="checkbox"/>	<input type="checkbox"/>	<input type="checkbox"/>	
10. If walls are tiered, then are they in accordance with project criteria?, e.g., bench widths, aesthetics within benches, etc.	Spec/ Section 6.2	<input type="checkbox"/>	<input type="checkbox"/>	<input type="checkbox"/>	
11. If instrumentation is required per project specs, then is it provided? (List the instrumentation in the comments column)	PGR/ Spec	<input type="checkbox"/>	<input type="checkbox"/>	<input type="checkbox"/>	
12. Are corrosion/durability protection details acceptable?	Spec/ Section 3.5	<input type="checkbox"/>	<input type="checkbox"/>	<input type="checkbox"/>	
{add as appropriate, may be agency or project specific}		<input type="checkbox"/>	<input type="checkbox"/>	<input type="checkbox"/>	
{add as appropriate, may be agency or project specific}		<input type="checkbox"/>	<input type="checkbox"/>	<input type="checkbox"/>	

		Reference (See Note 3)	Yes	No	NA	Comments/ Action Required
VII.	SOIL REINFORCEMENT					
1.	Is the soil reinforcement type (extensible or inextensible) and configuration (strip, grid or sheet) in conformance with pre-approved list?	APL	<input type="checkbox"/>	<input type="checkbox"/>	<input type="checkbox"/>	
2.	Are the following soil reinforcement dimensions in conformance with those approved by the Agency during the pre-approval process?	APL				
	a. strip thickness or bar diameter	APL	<input type="checkbox"/>	<input type="checkbox"/>	<input type="checkbox"/>	
	b. strip width or bar mat width	APL	<input type="checkbox"/>	<input type="checkbox"/>	<input type="checkbox"/>	
	c. center to center spacing of the longitudinal bars in bar mats	APL	<input type="checkbox"/>	<input type="checkbox"/>	<input type="checkbox"/>	
	d. center to center spacing of the transverse bars in bar mats	APL	<input type="checkbox"/>	<input type="checkbox"/>	<input type="checkbox"/>	
	e. Geosynthetic grid (uniaxial/biaxial) openings and junction sizes	APL	<input type="checkbox"/>	<input type="checkbox"/>	<input type="checkbox"/>	
3.	Is the connection of the soil reinforcement to the facing units as per the pre-approved connection detail?	APL	<input type="checkbox"/>	<input type="checkbox"/>	<input type="checkbox"/>	
4.	Is the soil reinforcement specified to have the correct type and thickness of the corrosion protection as per the project specifications?	Spec/ Section 3.5	<input type="checkbox"/>	<input type="checkbox"/>	<input type="checkbox"/>	
5.	Is all soil reinforcement, except at acute angle corners, perpendicular to the face of the wall facing units? If no, please comment.	Spec/ PGR	<input type="checkbox"/>	<input type="checkbox"/>	<input type="checkbox"/>	
6.	Is all soil reinforcement connected to facing units?	Spec	<input type="checkbox"/>	<input type="checkbox"/>	<input type="checkbox"/>	
7.	If metallic soil reinforcements are cut and/or spliced then have the corrosion protection measures at cuts/connections been provided and are they acceptable? (Note: cutting transverse bars of bar mats is not allowed)	Spec/ APL	<input type="checkbox"/>	<input type="checkbox"/>	<input type="checkbox"/>	
8.	Are means and methods for splicing of geosynthetic reinforcement (overlap, mechanical connections, edge seams, etc.) in accordance with that approved by the Agency during the pre-approval process?	APL	<input type="checkbox"/>	<input type="checkbox"/>	<input type="checkbox"/>	
9.	Are placement procedures for reinforcement acceptable?	APL	<input type="checkbox"/>	<input type="checkbox"/>	<input type="checkbox"/>	
	{add as appropriate, may be agency or project specific}		<input type="checkbox"/>	<input type="checkbox"/>	<input type="checkbox"/>	
	{add as appropriate, may be agency or project specific}		<input type="checkbox"/>	<input type="checkbox"/>	<input type="checkbox"/>	

		Reference (See Note 3)	Yes	No	NA	Comments/ Action Required
VIII.	EXTERNAL STABILITY					
1.	Have all assumed soil parameters (Cohesion, Angle of Internal Friction, Soil Unit Weight, and Sliding Friction Coefficient) for retained, reinforced and foundation soils been listed?	PGR/Spec/ Section 3.3, 4.4.6	<input type="checkbox"/>	<input type="checkbox"/>	<input type="checkbox"/>	
2.	Are soil parameters consistent with those recommended in the geotechnical report / project specifications?	PGR/Spec	<input type="checkbox"/>	<input type="checkbox"/>	<input type="checkbox"/>	
3.	Have the maximum bearing pressures been listed along the length of the wall?	Vendor drawings	<input type="checkbox"/>	<input type="checkbox"/>	<input type="checkbox"/>	
4.	Have all the loads been incorporated into the wall analysis and design? (e.g., traffic loads, seismic loads, sloping surcharge, broken-back surcharges, etc.)	PGR/ Section 4.4.4	<input type="checkbox"/>	<input type="checkbox"/>	<input type="checkbox"/>	
5.	Have all the critical sections along all walls been analyzed? (e.g., highest wall sections, sections where slopes above and below the walls are steepest, etc.)	Project Drawings/ PGR	<input type="checkbox"/>	<input type="checkbox"/>	<input type="checkbox"/>	
6.	Are the static and seismic analyses adequate (as per performance requirements) for the following failure modes?	Spec/Section 4.4.6, 7.1.1	<input type="checkbox"/>	<input type="checkbox"/>	<input type="checkbox"/>	
	a. Sliding	Spec/Section 4.4.6.a	<input type="checkbox"/>	<input type="checkbox"/>	<input type="checkbox"/>	
	b. Eccentricity (overturning)	Spec/Section 4.4.6.c	<input type="checkbox"/>	<input type="checkbox"/>	<input type="checkbox"/>	
	c. Bearing	Spec/Section 4.4.6.c				
	i. General bearing capacity	Spec/Section 4.4.6.c	<input type="checkbox"/>	<input type="checkbox"/>	<input type="checkbox"/>	
	ii. Local bearing capacity / lateral squeeze	Spec/Section 4.4.6.c	<input type="checkbox"/>	<input type="checkbox"/>	<input type="checkbox"/>	
	iii. Is the bearing resistance greater than the maximum bearing pressure at all locations along the wall?	PGR	<input type="checkbox"/>	<input type="checkbox"/>	<input type="checkbox"/>	
7.	Is the wall embedment equal to or greater than the project requirements?	PGR	<input type="checkbox"/>	<input type="checkbox"/>	<input type="checkbox"/>	
8.	Has total settlement analysis been performed?	PGR	<input type="checkbox"/>	<input type="checkbox"/>	<input type="checkbox"/>	
9.	Has differential settlement analysis been performed?	PGR	<input type="checkbox"/>	<input type="checkbox"/>	<input type="checkbox"/>	
10.	Have slip joints been provided to prevent stresses due to large anticipated differential settlements?	PGR/APL/ Section 5.4.5	<input type="checkbox"/>	<input type="checkbox"/>	<input type="checkbox"/>	
11.	Is an undercut needed due to soft or poor soils? If so, is the depth of treatment and the replacement material specified?	PGR/ Spec	<input type="checkbox"/>	<input type="checkbox"/>	<input type="checkbox"/>	

		Reference (See Note 3)	Yes	No	NA	Comments/ Action Required
12.	Will deep foundations be needed for very deep layers of soft/loose soils?	PGR/ Spec	<input type="checkbox"/>	<input type="checkbox"/>	<input type="checkbox"/>	
13.	Will waiting period(s) and stage construction be needed if the design wall pressure exceeds the maximum allowable bearing pressure?	PGR/ Spec	<input type="checkbox"/>	<input type="checkbox"/>	<input type="checkbox"/>	
	{add as appropriate, may be agency or project specific}		<input type="checkbox"/>	<input type="checkbox"/>	<input type="checkbox"/>	
	{add as appropriate, may be agency or project specific}		<input type="checkbox"/>	<input type="checkbox"/>	<input type="checkbox"/>	
IX.	INTERNAL STABILITY					
1.	Have calculations for internal stability of the wall been performed?	PGR/ Spec	<input type="checkbox"/>	<input type="checkbox"/>	<input type="checkbox"/>	
2.	Has the static and seismic internal stability evaluation been performed by the “Simplified Method”?	PGR/Spec/ Section 7.1	<input type="checkbox"/>	<input type="checkbox"/>	<input type="checkbox"/>	
3.	Have all the critical sections along all walls been analyzed? (e.g., highest wall sections, sections where slopes above and below the walls are steepest, etc.)	Project Drawings/ PGR	<input type="checkbox"/>	<input type="checkbox"/>	<input type="checkbox"/>	
4.	Is pullout resistance adequate at each level of the reinforcement?	PGR/Spec/ Section 4.7.h	<input type="checkbox"/>	<input type="checkbox"/>	<input type="checkbox"/>	
5.	Is the correct value of nominal strength of steel used? (e.g., $0.55 F_y$ for strips and $0.48F_y$ for bar mats)	PGR/Spec/ Section 3.5	<input type="checkbox"/>	<input type="checkbox"/>	<input type="checkbox"/>	
6.	Are corrosion loss rates in conformance with project criteria?	PGR/Spec/ Section 3.5	<input type="checkbox"/>	<input type="checkbox"/>	<input type="checkbox"/>	
7.	Has the cross-sectional area for the soil reinforcement been corrected for corrosion losses over the design life of the structure?	PGR/Spec/ Section 3.5	<input type="checkbox"/>	<input type="checkbox"/>	<input type="checkbox"/>	
8.	Is resistance against tensile failure adequate at each level of reinforcement?	PGR/Spec/ Section 4.4.7.f	<input type="checkbox"/>	<input type="checkbox"/>	<input type="checkbox"/>	
9.	Are the connections designed for maximum tension in soil reinforcements?	Spec/Section 4.4.7.i	<input type="checkbox"/>	<input type="checkbox"/>	<input type="checkbox"/>	
10.	Have the proper values of F^* (including C_u , F_q , α_β , $\tan\phi$ and variation with depth) been used?	Section 3.4, 4.4.7.h	<input type="checkbox"/>	<input type="checkbox"/>	<input type="checkbox"/>	
11.	Is the correct value for the scale correction factor, α , been used?	Section 3.4, 4.4.7.h	<input type="checkbox"/>	<input type="checkbox"/>	<input type="checkbox"/>	
12.	Is the correct value of unit perimeter, C , used?	Section 3.4, 4.4.7.h	<input type="checkbox"/>	<input type="checkbox"/>	<input type="checkbox"/>	
13.	For geosynthetic reinforcement have the reduction factors for creep (RF_{CR}), durability (RF_D) and installation damage (RF_{ID}) been specified and are they acceptable?	Section 3.5/ Spec	<input type="checkbox"/>	<input type="checkbox"/>	<input type="checkbox"/>	

		Reference (See Note 3)	Yes	No	NA	Comments/ Action Required
14.	For geosynthetic reinforcement is the computation of long-term allowable strength acceptable?	Section 3.5/ Spec	<input type="checkbox"/>	<input type="checkbox"/>	<input type="checkbox"/>	
15.	Have the correct stress ratio (K_r/K_a) and lateral pressure coefficient (K_a) been used for computing internal loads?	Section 4.4.7.c, Figure 4-10	<input type="checkbox"/>	<input type="checkbox"/>	<input type="checkbox"/>	
16.	Has the correct internal failure surface been used for static and seismic cases?	Section 4.4.7.b	<input type="checkbox"/>	<input type="checkbox"/>	<input type="checkbox"/>	
17.	Has the vertical stress been computed as per the requirements of the Simplified Method?	Section 4.4.7.e				
18.	Are the definitions of the reinforcement configuration (grid openings, ratios of the bar diameters to spacing of bars in bar mats, etc.) consistent with pre-approved product list?	APL/Section 3.4	<input type="checkbox"/>	<input type="checkbox"/>	<input type="checkbox"/>	
19.	Have all the external loads been incorporated into the wall analysis and design? (e.g., traffic impact loads, seismic loads, sloping surcharge, broken-back surcharges, etc.)	Section 4.4.5, 7.1.1	<input type="checkbox"/>	<input type="checkbox"/>	<input type="checkbox"/>	
20.	Have all the internal loads been incorporated into the wall analysis and design? (e.g., lateral loads from piles at abutments or overhead mast structures)	PGR/Spec/ Section 4.4.7, 6.1	<input type="checkbox"/>	<input type="checkbox"/>	<input type="checkbox"/>	
21.	Has the internal stability evaluation accounted for complex geometries such as tiered structures, acute corners, back-to-back walls, and obstructions?	PGR/Spec/ Section 6.1 – 6.6	<input type="checkbox"/>	<input type="checkbox"/>	<input type="checkbox"/>	
22.	Is the vendor's analysis acceptable to the Geotechnical Engineer of Record based on an independent verification using "Simplified Method" and MSEW 3.0 or hand calculations? Please attach a copy of the verification calculations using the Simplified Method.	GER/ PGR	<input type="checkbox"/>	<input type="checkbox"/>	<input type="checkbox"/>	
	{add as appropriate, may be agency or project specific}		<input type="checkbox"/>	<input type="checkbox"/>	<input type="checkbox"/>	
	{add as appropriate, may be agency or project specific}		<input type="checkbox"/>	<input type="checkbox"/>	<input type="checkbox"/>	
X.	GLOBAL / COMPOUND STABILITY					
1.	Has the owner's geotechnical engineer of record checked global stability?	PGR	<input type="checkbox"/>	<input type="checkbox"/>	<input type="checkbox"/>	
2.	Has the vendor checked compound stability?	PGR/Spec/ Section 4.4.10	<input type="checkbox"/>	<input type="checkbox"/>	<input type="checkbox"/>	
3.	Has the vendor checked the global stability?	PGR/Spec	<input type="checkbox"/>	<input type="checkbox"/>	<input type="checkbox"/>	

		Reference (See Note 3)	Yes	No	NA	Comments/ Action Required
4.	Is the safety factor against global stability failure adequate?	PGR/Spec	<input type="checkbox"/>	<input type="checkbox"/>	<input type="checkbox"/>	
5.	Is the safety factor against compound stability failure adequate?	PGR/Spec	<input type="checkbox"/>	<input type="checkbox"/>	<input type="checkbox"/>	
6.	Are the geotechnical parameters for global and compound stability analyses appropriate and consistent with those used for other failure modes?	PGR/Spec	<input type="checkbox"/>	<input type="checkbox"/>	<input type="checkbox"/>	
7.	Is ground improvement needed based on global stability analysis?	PGR	<input type="checkbox"/>	<input type="checkbox"/>	<input type="checkbox"/>	
	{add as appropriate, may be agency or project specific}		<input type="checkbox"/>	<input type="checkbox"/>	<input type="checkbox"/>	
	{add as appropriate, may be agency or project specific}		<input type="checkbox"/>	<input type="checkbox"/>	<input type="checkbox"/>	
XI. FILE INFORMATION						
1.	Has the Geotechnical Engineer of Record completed this checklist? If not, who?		<input type="checkbox"/>	<input type="checkbox"/>	<input type="checkbox"/>	
2.	Has a representative from agency's _____ Group ensured that this checklist has been completed and outstanding issues identified?		<input type="checkbox"/>	<input type="checkbox"/>	<input type="checkbox"/>	
	{add as appropriate, may be agency or project specific}		<input type="checkbox"/>	<input type="checkbox"/>	<input type="checkbox"/>	
	{add as appropriate, may be agency or project specific}		<input type="checkbox"/>	<input type="checkbox"/>	<input type="checkbox"/>	

LIST OF ATTACHMENTS BY ENGINEER OF RECORD

No.	Attachment	Comments/Action Required
1		
2		
3		
4		
5		
6		
7		
8		
9		
10		

As a minimum the ER should include an attachment that identifies the specific issues that need to be addressed by the MSE wall designer (vendor).

4.7 COMPUTER-AIDED DESIGN

The repetitive nature of the computations required at each level of reinforcement lends itself to computer-assisted design. The computer program MSEW (ADAMA, 2000) developed under FHWA sponsorship analyzes and/or designs MSE walls using any type of metallic or geosynthetic reinforcement in conjunction with any type of facing (precast concrete, MBW, etc.). Version 1.0 has been designated exclusively for use by U.S. State Highway Agencies and by U.S. Federal agencies and performs computations in compliance with the ASD design methods in FHWA (Elias et al., 2001) and AASHTO (2002). Version 3.0 is available for purchase through ADAMA Engineering (www.MSEW.com) and includes LRFD-based computations. Alternatively, spreadsheet based solutions can be developed. The example problems in Appendix E, provide comprehensive step-by-step solutions that can be easily programmed into a spreadsheet.

Other MSE wall analysis and design programs are available. Many wall vendors have their own programs that are tailored to their system, and may have additional features for estimating quantities and costs. Agency personnel should understand the features and finer points of the computer program and spreadsheets that they use to design or check vendor designs. Likewise, wall vendors and design consultants should understand the features and finer points of computer programs and spreadsheets they use. This is particularly important with the recent change to an LRFD design platform.

4.8 VENDOR DESIGNS

As previously discussed, it is recommended that Agencies use a pre-approved proprietary wall system list (an approved products list) for specifying MSE walls with a performance or end-result approach. Specific wall systems and respective vendors, along with any application restrictions (e.g., height limit), are provided on the list. Detailed evaluations are typically required for placement on an approved products list. The design program and spreadsheets used by the vendor should be reviewed by the Agency as part of this evaluation.

4.9 STANDARD MSEW DESIGNS

MSEW structures are customarily designed on a project-specific basis. Most agencies use a line-and-grade contracting approach, with the contractor selected MSEW vendor providing the detailed design after contract bid and award. This approach works well for segmental and full-height panel faced walls, and can be used for MBW unit faced walls. However, standard

designs can be developed and implemented by an agency for MSEW structures, somewhat similar to standard concrete cantilever wall designs used by many agencies.

Use of standard designs for MSEW structures could offer the following advantages over a line-and-grade approach:

- Agency is more responsible for design details and integrating wall design with other components.
- Pre evaluation and approval of materials and material combinations, as opposed to evaluating contractor submittal post bid.
- Economy of agency design versus vendor design/stamping of small walls.
- Agency makes design decisions versus vendors making design decisions.
- More equitable bid environment as agency is responsible for design details, and vendors are not making varying assumptions.
- Reduces the possibility of substandard work, systems and designs with associated approved product lists.

The Minnesota Department of Transportation (Mn/DOT), with support of the FHWA (via Demo 82 project) developed and implemented standardized MSEW designs (Berg, 2000) for MBW unit faced and geosynthetic reinforced MSEW structures. The use of these standard designs are limited by geometric, subsurface and economic constraints. Structures outside of these constraints should be designed on a project-specific basis. The general approach used in developing these standards could be followed by other agencies to develop their own, agency-specific standard designs.

Standardized designs require generic designs and generic materials. Generic designs require definition of wall geometry and surcharge loads, soil reinforcement strength, structure height limit, and MBW unit properties of width and batter. As an example, the Mn/DOT standard designs address four geometric and surcharge loading cases, and could be used for walls up to 23 ft (7 m) in height. Since original development the number of cases has been reduced to three and the maximum height has been reduced to 12 ft (3.6 m) due to MBW durability concerns (see Section 3.6.2 for discussion on MBW freeze-thaw durability).

Definition of generic material properties for the standard designs requires the development of approved product lists for MBW units, soil reinforcement and MBW unit-soil reinforcement combinations. The combinations require a separate approved product list as the connection strength is specific to each unique combination of MBW unit and reinforcement, and often controls the reinforcement design strength. An additional requirement for MBW units is an approved manufacturing quality control plan on file with the agency. This requirement is a

result of the stringent durability (to freeze thaw and deicing salt conditions) specifications for the units and the long duration testing used to demonstrate durability.

An example design cross section and reinforcement layout table from the Mn/DOT standard designs are presented in Figure 4-19 and Table 4-8. A list of approved combinations (Mn/DOT, 2009) of MBW units and soil reinforcements with classification as MBW-700, MBW-1050, or MBW-1400, is used in conjunction with the table and figure. Note that the Mn/DOT standard designs are not directly applicable to, nor should they be used by, other agencies.

Another example of an agency standard design is Washington DOT’s geosynthetic walls. Standard designs for two stage construction of walls up to 35 ft (11 m) are provided. The geosynthetic wrap-around walls are constructed in the first stage. The walls can be faced with shotcrete or cast-in-place concrete in the second stage.

Table 4-8. Example MBW Faced MSE Wall Standard Design (Minnesota DOT, 2008).

MODULAR BLOCK WALL REINFORCEMENT LAYOUT														
— CASE 4 - 1:3 FILL SLOPE —														
MBW Reinforcement Class	Strength of Soil Reinf. (plf)		Minimum Reinforcement Length, L (ft)	Maximum Wall Height (ft)	Nominal Block Width (in.)	Wall Batter Range (degrees)		Maximum Unreinforced Wall Height (in.)	Zone 1		Zone 2		Zone 3	
	L. Term (Tal)	Design (Ta)				≥	<		H1 (ft)	S1 _{max} (in.)	H2 (ft)	S1 _{max} (in.)	H3 (ft)	S1 _{max} (in.)
MBW-700	1050	700	0.7 H	12.0	12	0	3	24	8.5	24	3.5	16		
						3	7	24	9.2	24	2.8	16		
						7	10	24	11.2	24	0.8	16		
						10	15	24	12.0	24				
					21	0	3	42	4.6	32	3.9	24	3.5	16
						3	7	42	5.2	32	3.9	24	2.9	16
						7	10	42	5.2	32	5.9	24	0.9	16
						10	15	42	5.9	32	6.1	24		
MBW-1050	1575	1050	0.7 H	12	12.0	0	3	24	12.0	24				
						3	7	24	12.0	24				
						7	10	24	12.0	24				
						10	15	24	12.0	24				
					21	0	3	42	5.6	42	3.3	32	3.1	24
						3	7	42	8.2	42	2.6	32	1.2	24
						7	10	42	8.5	42	3.5	32		
						10	15	42	9.8	42	2.2	32		
MBW-1400	2100	1400	0.7 H	12	12.0	0	3	24	12.0	24				
						3	7	24	12.0	24				
						7	10	24	12.0	24				
						10	15	24	12.0	24				
					21	0	3	42	8.9	42	3.1	32		
						3	7	42	10.8	42	1.2	32		
						7	10	42	12.0	42				
						10	15	42	12.0	42				

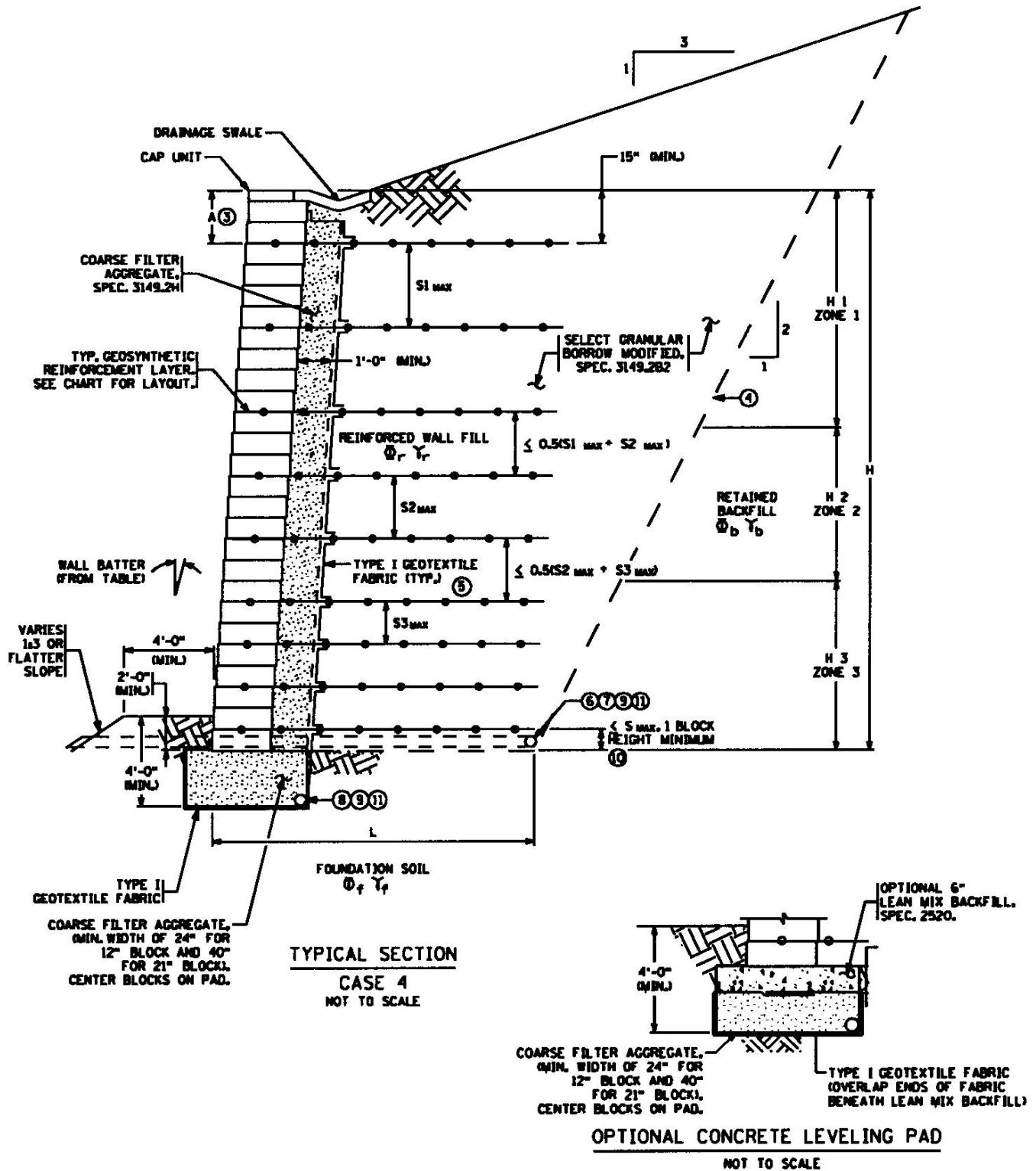

Figure 4-19. Example of standard MSEW design. (Minnesota DOT, 2008)

CHAPTER 5

MSE WALL DETAILS

Proper attention to details of various components is critical to the successful implementation of MSE wall projects. This Chapter discusses various details related to the following elements of MSE walls:

- Top of wall elements such as copings, traffic barriers and geomembrane caps
- Bottom of wall elements such as leveling pads
- Drainage features such as filters, drains and pipes
- Internal elements such as obstructions in reinforced soil mass and slip joints
- Wall initiations and terminations
- Aesthetics

The example details shown in this chapter have been used successfully in actual projects. However, these details may need modifications to fit the requirements of specific projects. Therefore, the user should treat the details in this chapter as initial guidance and modify them as appropriate before actual implementation on a given project and for a given product.

5.1 TOP OF WALL ELEMENTS

The top of wall is important from both aesthetic as well as technical aspects. Aesthetically, the top of a MSE wall should provide a smooth profile. Technically, the top of wall needs to integrate roadway elements such as pavements, traffic barriers, and drainage features.

5.1.1 Copings

The purpose of a coping is to create a smooth and aesthetically pleasing clean line at the top of an MSE wall. Copings can be cast-in-place or precast. Precast coping can generally be installed more rapidly than cast-in-place coping. Figures 5-1a to 5-1c provide common details for cast-in-place and precast copings for segmental precast concrete facing units. Figure 5-1d shows a common detail for a precast cap unit on top of modular block wall.

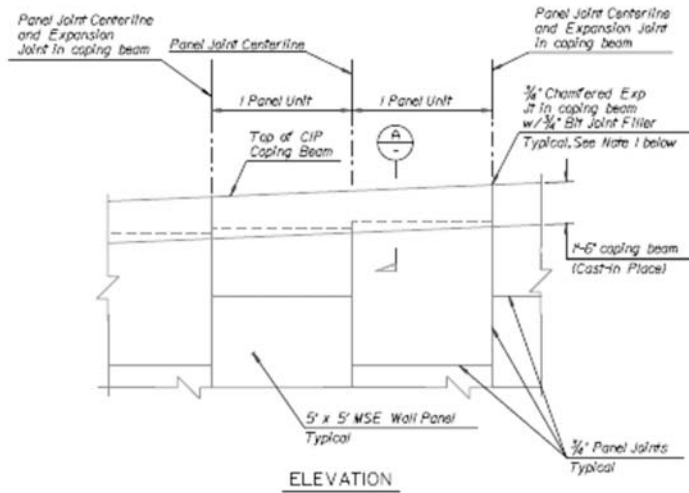

(a)

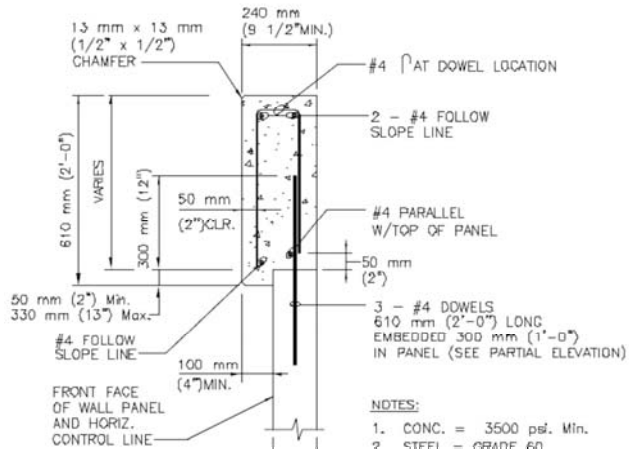

(b)

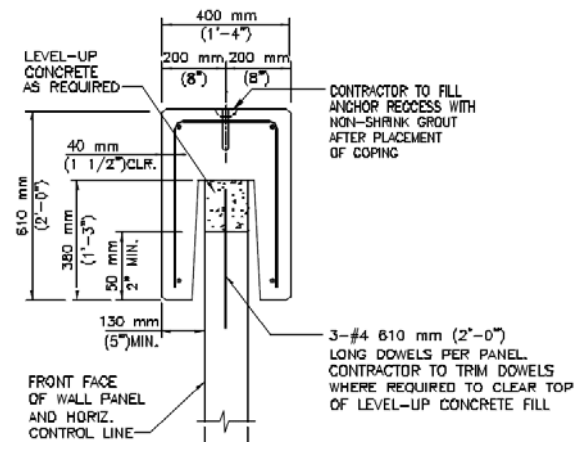

(c)

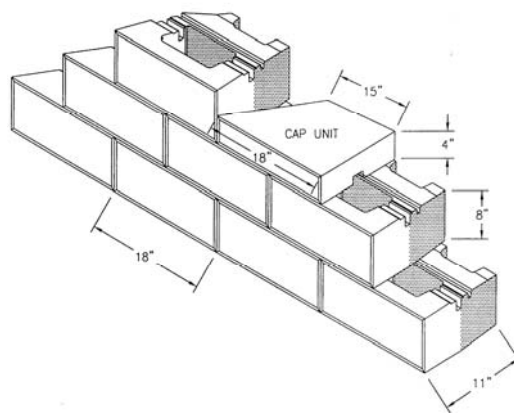

(d)

Figure 5-1. Example copings for MSE walls.

Regardless of whether the coping is cast-in-place or precast, the coping should have full-depth open joints, i.e., reinforcement should not be continuous across the joints. General guidance for copings is as follows:

- For segmental precast concrete facing units, the joints for a cast-in-place coping should align with the vertical joints in the MSE wall face at a frequency not exceeding 10 ft (3 m) on centers with a preferable frequency of every panel width. The spacing of the joints may be increased to 20 ft (6 m) if differential settlement is not a concern.
- For modular block facing units, the joints in a cast-in-place coping should line up with the vertical joints in the face at a frequency not exceeding 5 ft (1.5 m) or less as required to line up with block joints. The spacing of the joints may be increased to 10 ft (3 m) if differential settlement is not a concern. Precast cap units should have a width equal to the width of a modular block unit and should be attached to the top modular facing unit using a mortar and pin connection. Adhesives should not be used for permanent structures unless the agency is prepared to perform continuous maintenance to check and reattach the cap blocks as necessary. Warranties for separation and displacement of glued cap blocks are, at best, usually on the order of ten years and that assumes that blocks meet the required installation conditions of the adhesive manufacturer, e.g., the blocks are clean, dry and bonded at the required curing temperature.

The cast-in-place coping can provide a smooth finish and be adjusted to meet final top of wall elevations after settlements have occurred. Cast-in-place copings are also recommended in situations where a wall follows a horizontal or vertical curve with less than a 100 ft (30 m) curve. Since precast coping sections are cast with square ends, joints between coping sections as seen from the front of the wall may become too tight or too wide depending on whether the radius point is in front or behind the wall face, respectively. Custom fitted cast-in-place coping should be used at kink points and corners in the wall and at slip joints so that the in-plane movement on each side of the slip joint can be tolerated without compromising the purpose of the slip joint.

Before installing precast coping, the top of the wall must be smooth and free of steps or irregularities. To accomplish this, level-up concrete is cast on top of the facing units. The smooth finished grade of this concrete fill should follow a line approximately 9 in. (225 mm) below the top of coping elevation. Top facing units that are to receive precast coping may have protruding dowels that tie in to the level-up concrete. The dowels are field trimmed 1 to 2 in. (25 to 50 mm) below the top of level-up concrete before pouring the level-up concrete.

5.1.2 Traffic Barriers

Figure 5-2 presents a variety of traffic barrier configurations. Typically, the base (or moment) slab length is a minimum of 20 ft (6 m) and jointed to adjacent slabs with shear dowels. The width typically varies from 4 ft (1.2m) to 6 ft (1.8m). The actual designs of traffic barriers should be in accordance with AASHTO (2007). In all cases, the base slab must be sized to prevent overturning and sliding of the barrier system during impact. When the base slab extends over the tops of the facing units to form a coping, a recess into which the facing units fit must be designed in the underside of the slab and a positive bond breaker must be provided to ensure isolation of the barrier from the facing units. Both vertical and horizontal bond breaks are required to avoid direct impact loads on the facing unit and to prevent prying loads on the top panels during traffic loading. If a precast coping or precast traffic barrier is used, the top of the wall must be smooth and free of steps or irregularities. To accomplish this, level-up concrete fill is cast on top of the facing units (similar to that for coping).

5.1.3 Parapets

Where only pedestrian or bicycle loads are anticipated, the safety railing may be in the form of a concrete pedestrian parapet. A parapet is a cast-in-place or precast concrete rail located directly or nearly on top of the facing units. Although not designed for vehicular impact loading parapets do use a moment slab for stability. The moment slab may also serve as a sidewalk. The moment slab should be strong enough to resist the nominal (ultimate) strength of the pedestrian parapet. Where there is a possibility of vehicular load, the parapet should be protected by a non-mountable curb at the edge of the traveled roadway or the parapet be designed for impact load.

5.1.4 Post and Beam Barriers

Where post and beam barriers such as guardrail systems are used, the posts are driven directly into the reinforced soil mass or installed in concrete-filled forms placed during backfill placement and compaction. The posts should be placed at a minimum distance of 3 ft (1 m) from the wall face, driven 5 ft (1.5 m) below grade, and reinforced spaced to miss the posts where possible. If the reinforcements cannot be missed, the wall should be designed to account for the presence of an obstruction as discussed later in this Chapter.

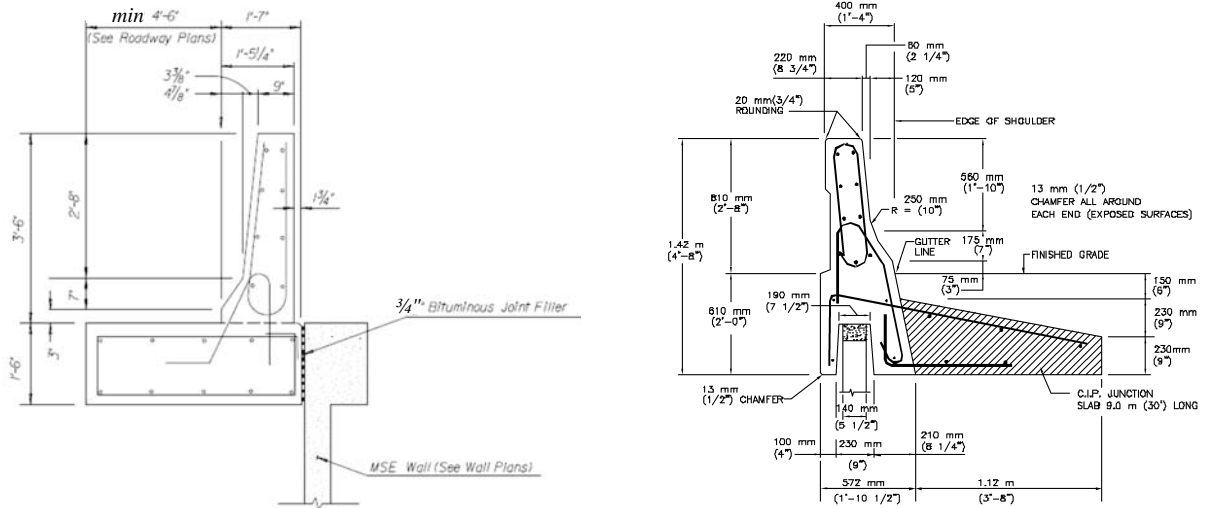

(a)

(b)

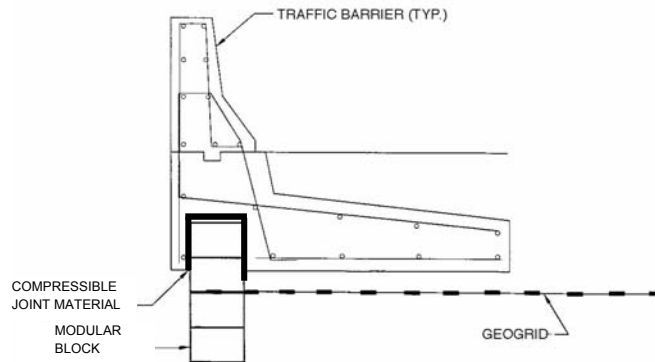

(c)

Figure 5-2. Example traffic barrier for MSE walls. (a) Barrier behind coping, (b) barrier on top of panels, (c) barrier on top of modular block units.

5.1.5 Drainage Related Top of Wall Elements

Whenever possible, the top surface of wall should be graded such that water drains away from the wall. A grassed swale or concrete ditch can be used behind the facing to collect and remove water. However, when this is not possible, depending on the configuration of the backslope with respect to the top of the wall and local hydrogeological considerations, several different details may need to be implemented from a drainage perspective. These elements are discussed in Section 5.3.

5.2 BOTTOM OF WALL ELEMENTS

The primary bottom of wall element is a leveling pad. Figure 5-3 shows common details of a leveling pad. Following are some considerations for the leveling pad:

- For structural walls, the leveling pad should be constructed from lean (e.g., 2,500 psi {17.2 MPa}) unreinforced concrete. The strength and thickness should be such that it allows cracking of the leveling pad during differential settlement as/if needed to relieve stress concentrations that can occur. Gravel pads may be allowed only for non-structural walls such as those for landscaping purposes.
- The common thickness of a leveling pad is 6 in. (150 mm). The width of the leveling pad should be such that it extends at least 3 in. (75 mm) beyond the thickness of the facing unit. Thus, for example, if the segmental precast concrete facing unit is 6 in. (150 mm) thick, then the width of the leveling pad shall be at least 12 in. (300 mm). At sharp curves the width of the leveling pad may be increased for segmental precast concrete facing units which are typically 5 ft (1.5 m) or 10 ft (3 m) wide so that the entire panel is resting on the leveling pad and at least 3 in. (75 mm) overhang of the leveling pad on each side of the facing unit.
- For ease of construction and to prevent misalignment of joints, the top of the leveling pad within any given step should be such that it does not vary by more than 1/8 in. (3 mm) over any 10 ft (3 m) run.
- Any openings between leveling pad steps should be completely filled after erection of the first row of panels. Where openings are more than 3 in. (75 mm) wide, filling with lean unreinforced cast-in-place concrete is preferred. For smaller openings, a geotextile filter with sufficient overlap of the panels and foundation soil could be used to fill openings.

When there is a roadway immediately adjacent to the bottom of the wall, it is advisable to provide a crash protection barrier to protect the wall against vehicular impact. The size and configuration of this barrier is a function of the vehicle sizes and speed limits on the roadway in front of the wall. An alternative to a crash barrier is a non-mountable, i.e., a high, curb at the edge of the traveled roadway adjacent to the wall.

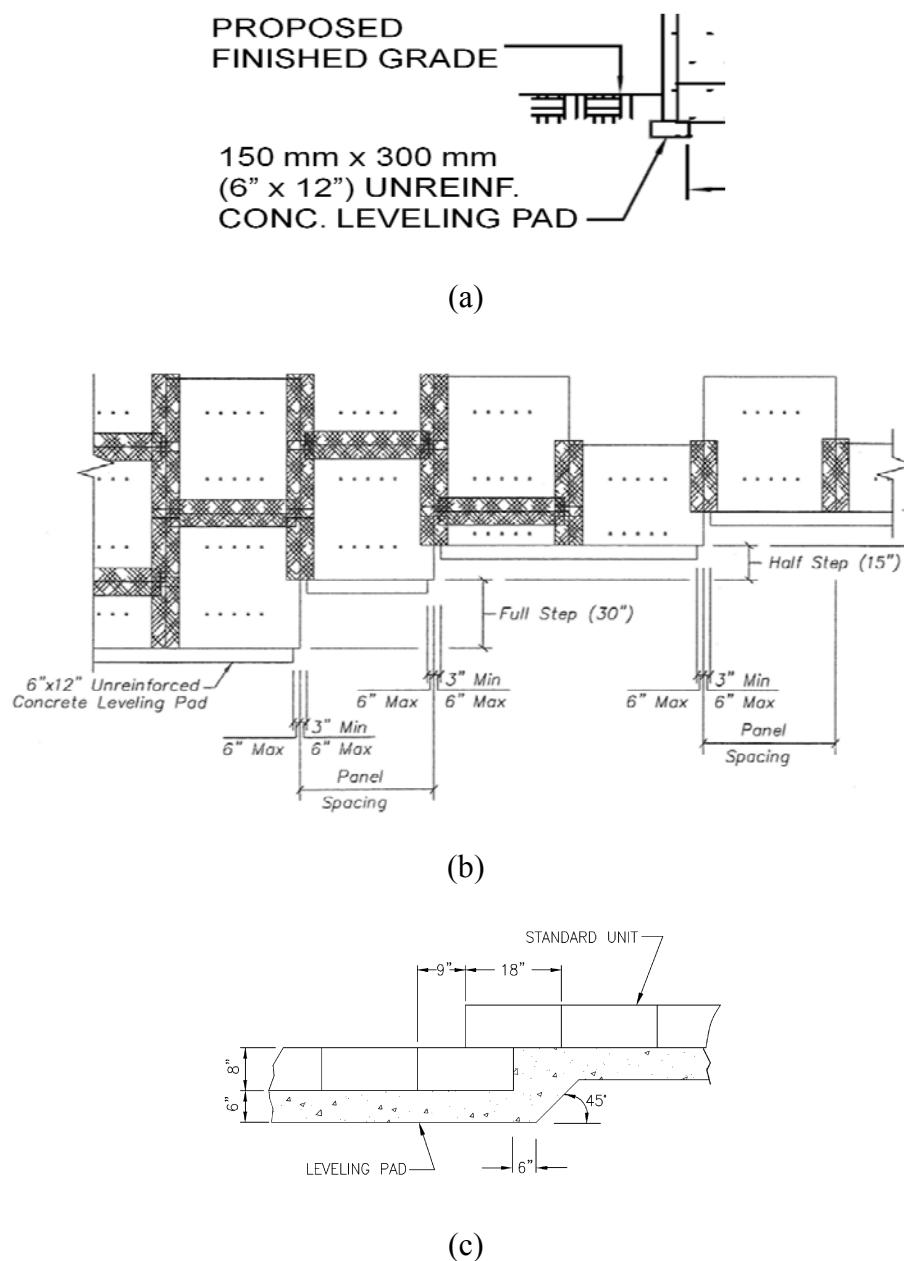

Figure 5-3. Leveling pads, (a) Common size, (b) Step detail for precast panel facing units, (c) Step detail for modular block facing units.

5.3 DRAINAGE

Good drainage is essential to the proper performance of an MSE wall. There are two types of drainage considerations for an MSE wall, internal and external. Internal drainage considerations are related to control of surface or subgrade water that may infiltrate the reinforced soil mass. The internal drainage of an MSE wall depends on the characteristics of the backfill used in the reinforced soil mass. External drainage considerations deal with water that may flow externally over and/or around the wall surface taxing the internal drainage and/or creating external erosion issues. The external drainage depends on the location of the MSE wall with respect to local hydrogeological factors and generally deals with diverting water flow away from the reinforced soil structure.

Regardless of the source of the water, i.e., internal or external, the cardinal rule in the design of MSE walls, as with any other wall type, is to allow unimpeded flow of water through the wall and/or collect and remove water before it enters the zone of influence of the wall to prevent the following:

- build-up of hydrostatic forces that increase lateral pressures,
- piping, i.e., erosion of one soil into another, which creates paths for additional water flow or clogging of drainage aggregate, and
- external soil erosion from the toe, around the edges or at the top of the wall.

It is recommended that adequate drainage features be required for all walls unless the engineer determines that such features are not needed for a specific project. During a determination of the need for drainage features, the engineer must include consideration for both subsurface (e.g., ground water, perched water, flooding and tidal action) and surface infiltration water (e.g., rain, runoff, and snow melt).

Effect of Fines on Drainage

Soil particles with sizes smaller than the U.S. No. 200 (0.075 mm) sieve are referred to as “fines.” The permeability of an overall soil mass is affected significantly by the amount of fines. In general, soils with less than 3 to 5% non-plastic fines by weight are considered to be free draining and water can readily flow through the soil mass even under low hydraulic gradients. In the case of MSE walls, a reinforced soil mass with less than 3 to 5% non-plastic fines will allow unimpeded flow provided the permeability of the reinforced fill is greater than the permeability of the retained fill and the wall is not exposed to significant water events such as flooding, tidal action or significant snow melt.

When the amount of the fines is more than 3 to 5%, the permeability is significantly reduced and drainage requirements must be carefully evaluated as groundwater and/or infiltration of surface water can result in build-up of seepage/hydrostatic forces within the reinforced soil mass. Surface water that infiltrates into the reinforced soil mass will tend to move toward the permeable face of an MSE wall and can have a destabilizing effect due to a potential increase in seepage forces (Terzaghi et al., 1996; Cedergren, 1989). Such a condition can occur during severe rainstorms, if the permeability of the fill is equal to or less than about 0.002 cm/sec (Terzaghi et al., 1996; Cedergren, 1989). Therefore, good drainage features should be incorporated into the design if low permeability reinforced fill is used, i.e., if the reinforced fill has more than 3 to 5% non plastic fines. Special precaution is also advised for hillside construction due to the potential for seepage to occur through retained soil and rock seams, faults and joints during rain events that may not be apparent during subsurface exploration and construction.

Internal and external drainage details, which represent good drainage, are presented in the following Sections 5.3.1 and 5.3.2, respectively. Good design of drainage features requires proper consideration of the filtration properties of various geomaterials within and external to the MSE wall as well as drains that are adequately sized to effectively remove any seepage water. The drainage components including filtration criteria and drain component requirements are presented in Section 5.3.3.

5.3.1 Internal Drainage Systems

There are two specific forms of internal drainage as shown in Figure 5-4, (a) drainage near wall face due to infiltration of surface water near the wall face, and (b) drainage behind and under reinforced soil mass from groundwater. Groundwater may be present at an elevation above the bottom of the wall and would flow to the MSE walls from an excavation backcut; or it may be present beneath the bottom of the MSE wall. A groundwater surface beneath a MSE wall may rise into the reinforced soil mass, depending on the hydrogeology of the site. Surface water may infiltrate into the reinforced soil mass from above or from the front face of the wall, for the case of flowing water in front of the structure.

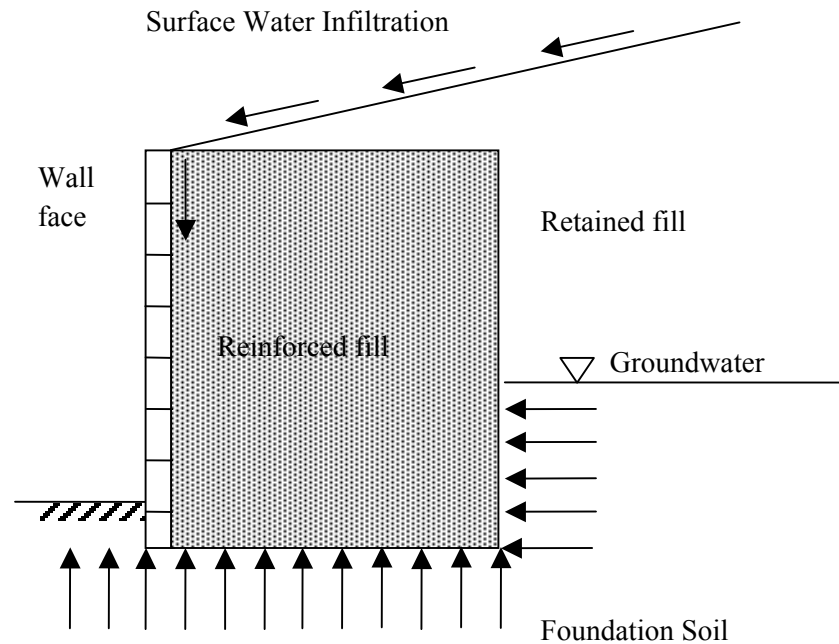

Figure 5-4. Potential sources and flowpaths of water.

Internal Drainage Near Wall Face

A filter is provided at all vertical and horizontal joints in the wall face to prevent the migration of fines from the reinforced soil mass through the joints. The location and configuration of the filter is a function of the type of wall facing units as follows:

- For segmental precast wall facing units, the filter is commonly in the form of geotextile fabric that is placed across all horizontal and vertical joints as shown in Figure 5-5. The geotextile should extend a minimum of 4 in. (100 mm) on either side of the joint and up into the coping to prevent soil from moving around the geotextile. The geotextile filter characteristics should be such that it is compatible with the backfill in the reinforced soil mass as discussed in Section 5.3.3.

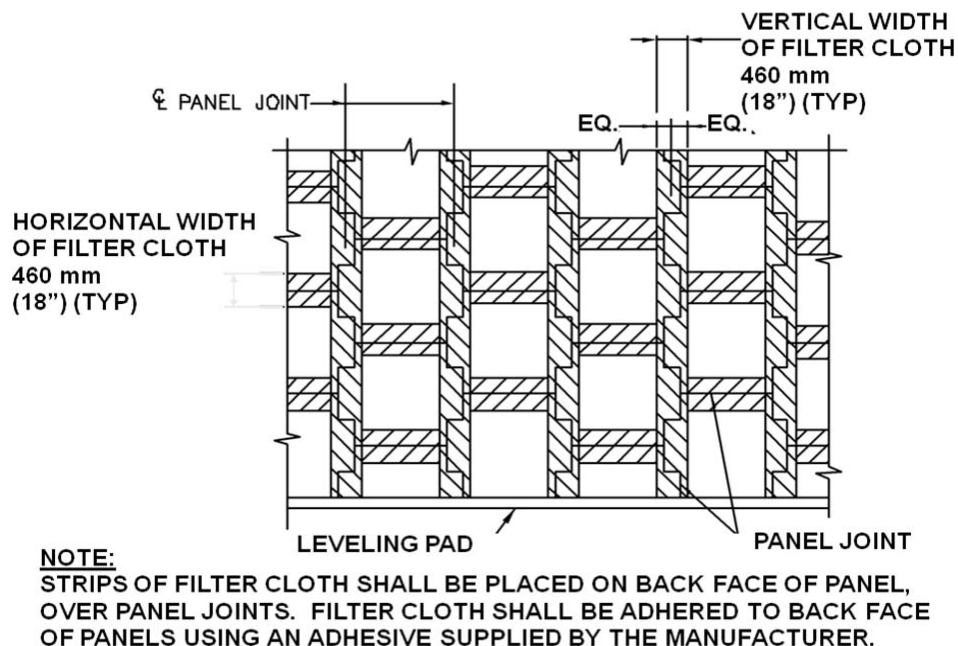

Figure 5-5. Example layout of filter at joints between segmental precast facing units.

- Modular block wall (MBW) facing units are typically constructed with a zone of free drainage aggregate adjacent to the back face of the units. The minimum width of this aggregate zone is typically 1 ft (300 mm). In addition to serving as a back face drain, this aggregate is required for stiffness of the wall face and constructability, i.e., placement and compaction of wall fill may be difficult based on the configuration of the MBW units. This column of aggregate is often a high permeability well graded gravel as discussed in Section 5.3.3. The gradation of the aggregate should be used to determine the maximum allowable vertical joint opening between MBW units, using slot criterion given by Equation 5-8 in Section 5.3.3. The configuration of the gravel filter is a function of whether the modular block unit is solid or with a hollow-core. For solid modular block units, the well graded gravel should be at least 1 ft (300 mm) wide as shown in Figure 5-6a. For hollow-core modular block units, the well graded gravel should be at least 1 ft (300 mm) wide with a minimum volume of 1 ft³ per ft² (0.3 m³/m²) of wall face as illustrated in Figure 5-6b. The gradation of the gravel should be sized to be compatible with the reinforced wall fill gradation in the reinforced soil mass, i.e. meet soil filter criteria as discussed in Section 5.3.3. Alternatively, a geotextile may be used between the gravel and reinforced wall fill to meet filtration requirements, as illustrated in Figure 5-6b. Finally, the construction sequence should be specified to ensure a workable drain system.

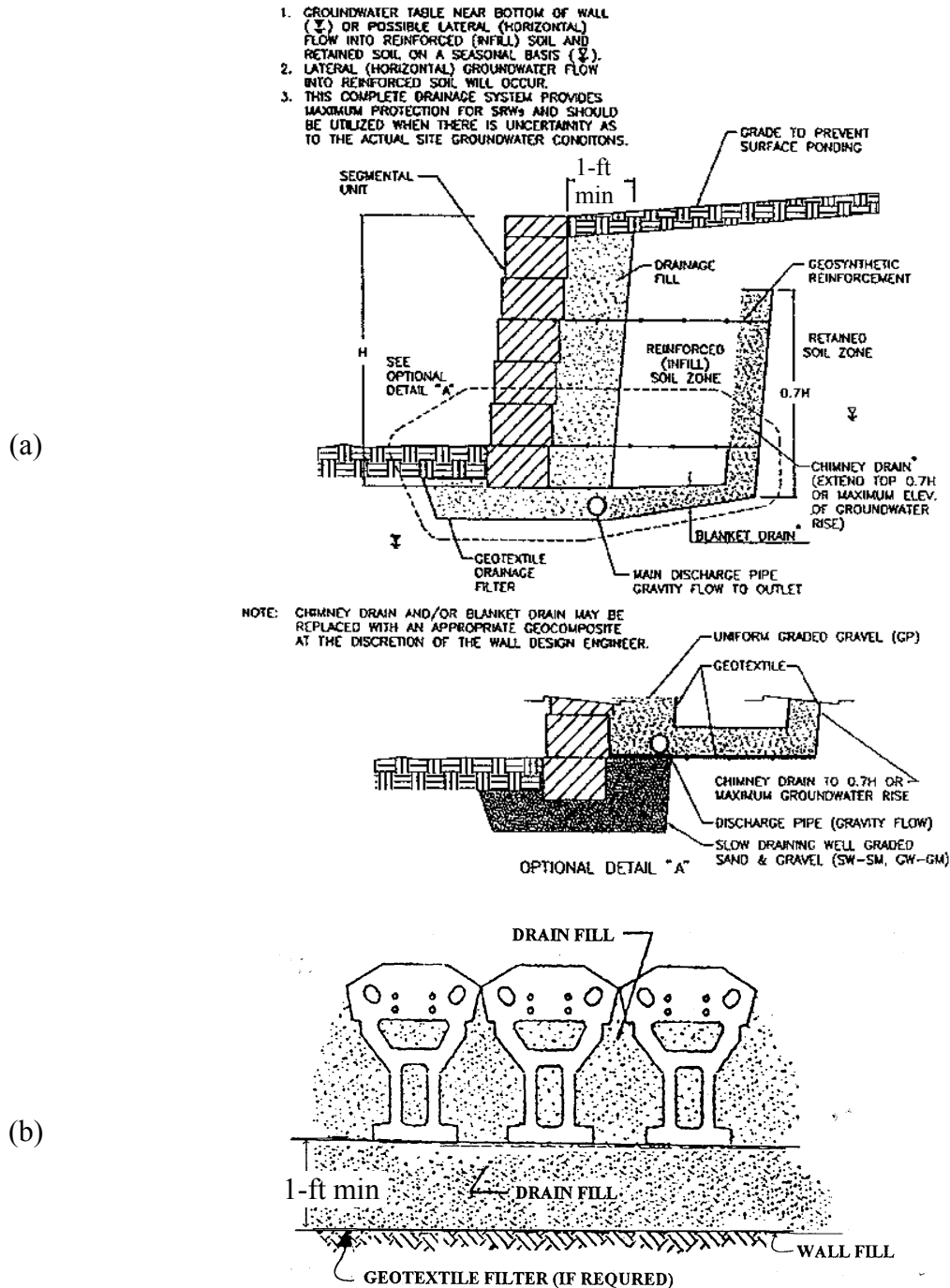

Figure 5-6. Layout of drainage fabric and drainage fill at the face for modular block units. (Collin et al., 2002).

- Figure 5-7 provides a common detail for face drainage in the case of wire-faced walls. In this case, the geotextile filter is placed between the facing stones and the reinforced soil mass.

Internal Drainage Under and Behind the MSE Wall

For walls in locations where groundwater can result in build-up of seepage/hydrostatic forces within the height of the reinforced soil mass and/or surface water infiltration is anticipated, a base drain that provides drainage beneath the MSE wall and a back or chimney drain that provides drainage behind the reinforced soil mass is strongly recommended to ensure proper long-term functionality of the MSE wall. This is because, as noted earlier, a reinforced fill with more than 3 to 5% non plastic fines is not “free draining.”

The base drain and back drain should be designed to collect and remove groundwater before it enters the reinforced mass and allows infiltration water to preferentially flow downward and toward the back of the wall, away from the face. An example of such a drainage system is illustrated in Figure 5-8 for segmental precast facing unit structure. Figure 5-6a shows a common detail for modular block unit faced structures. Figures 5-9 and 5-10 show alternative drainage systems that include geocomposite drains and blanket drains in lieu of open graded gravel drains with a geotextile or well-graded soil filter. Information on the various drains to relieve hydrostatic pressures is provided below. Design of the base drain and backdrain and the drainage system components is covered in Section 5.3.3.

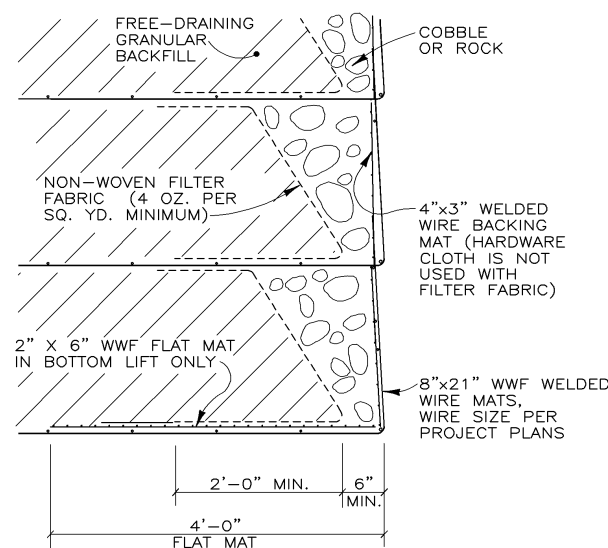

Figure 5-7. Example layout of geotextile filter near the face for welded wire facing units.

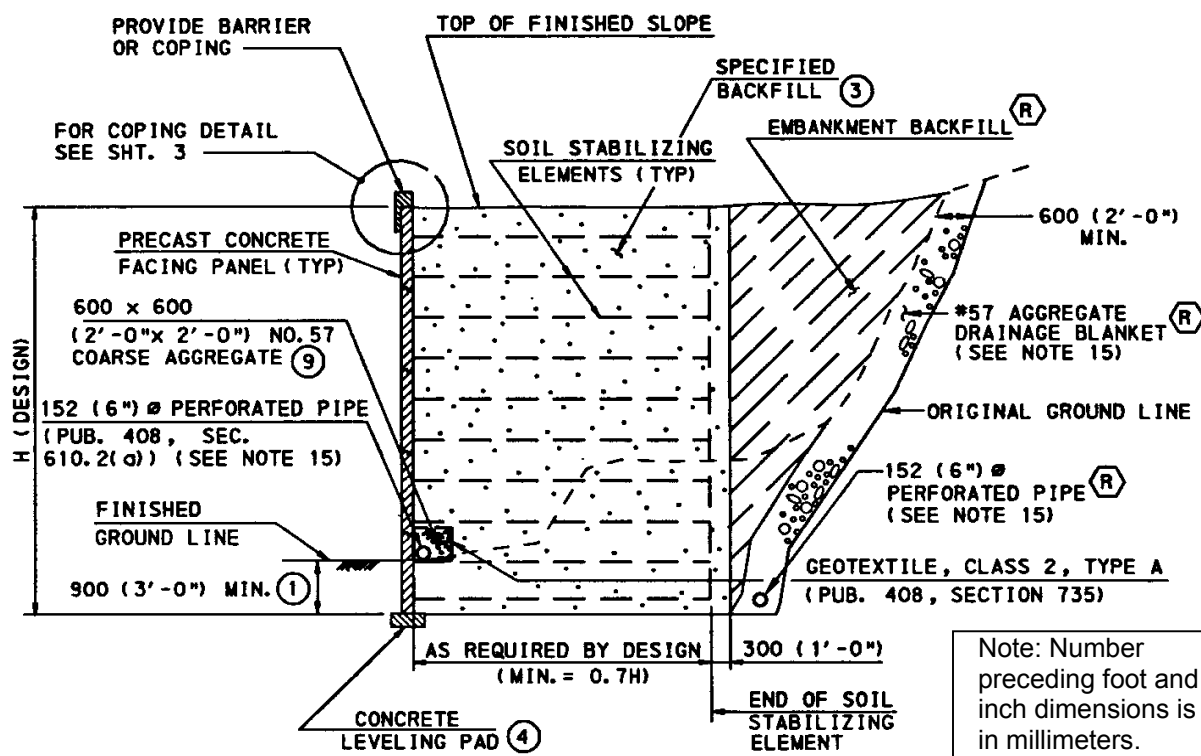

Figure 5-8. Example drainage blanket detail behind the retained backfill.

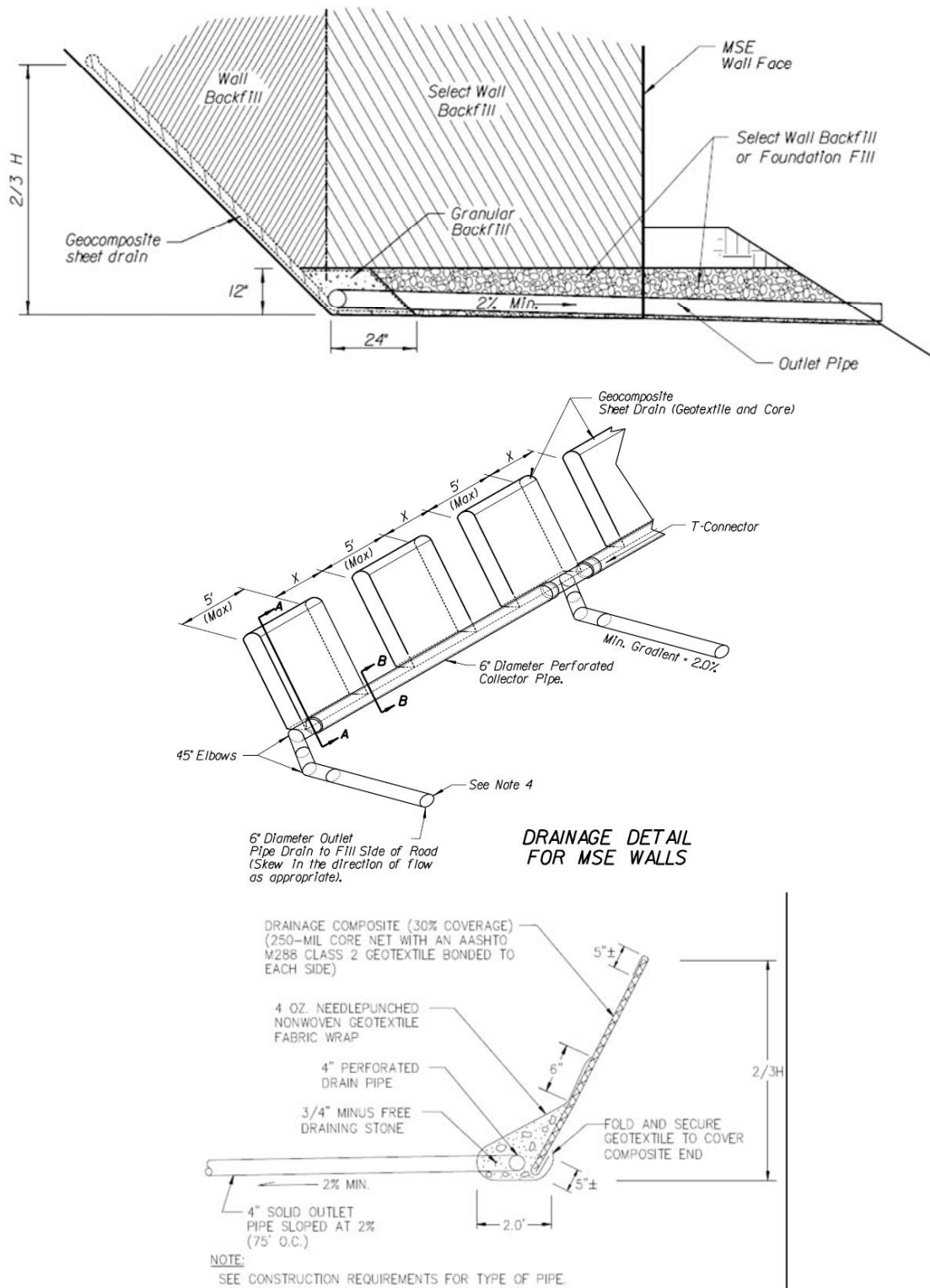

Figure 5-9. Example drainage detail using a geocomposite sheet drain.

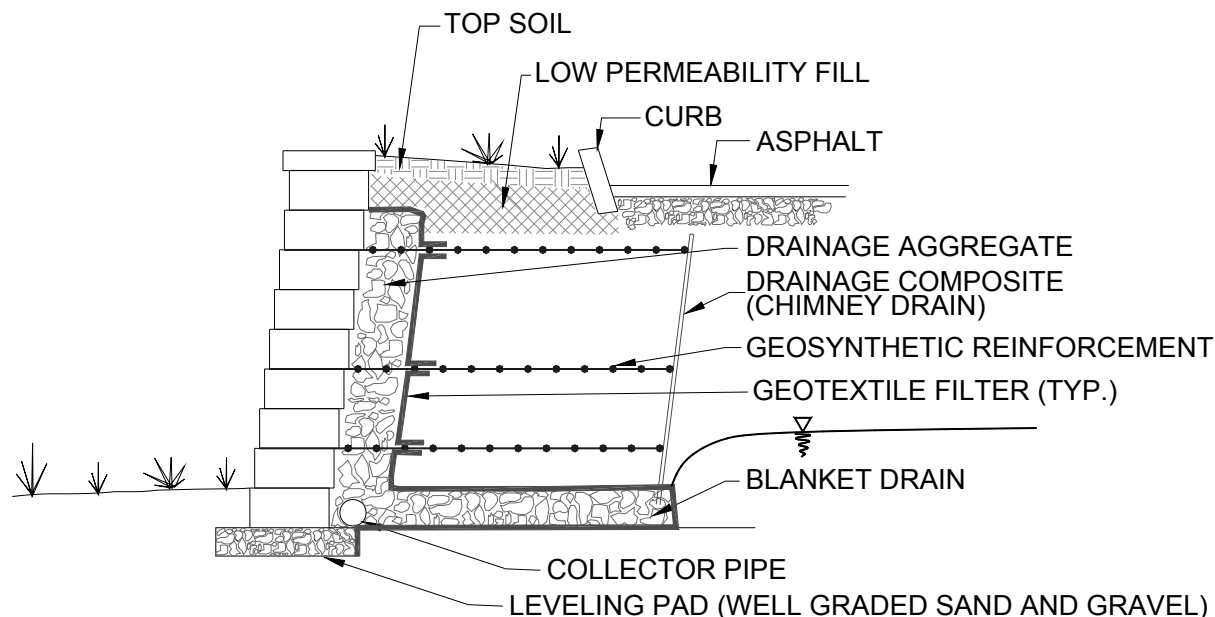

Figure 5-10. Example drainage detail using a blanket drain with chimney drain (Collin et al., 2002).

Walls with Possibility of Inundation

For walls potentially subject to inundation, such as those located adjacent to rivers, canals, detention basins or retention basins, a minimum hydrostatic pressure equal to 3 ft (1 m) should be applied at the high-water level for the design flood event. Effective unit weights should be used in the calculations for internal and external stability beginning at levels just below the equivalent surface of the pressure head line. Where the wall is influenced by water fluctuations, the wall should be designed for rapid drawdown conditions which could result in differential hydrostatic pressure greater than 3 ft (1 m). As an alternative to designing for rapid drawdown conditions, No. 57 coarse aggregate, as specified in AASHTO M 43, could be provided as reinforced backfill for the full reinforced zone of the wall and to the maximum height of submergence of the wall. A geotextile filter should be provided at the interface of the No. 57 coarse aggregate and reinforced backfill above it, at the interface of the retained backfill behind it, and at the interface of the coarse gravel and subgrade beneath it, unless the coarse aggregate meets the soil filtration criteria for the adjacent soils (see Section 5.3.3). The geotextile should meet the filtration and survivability criteria in Section 5.3.3. Adjoining sections of geotextile filter/separator shall be overlapped by a minimum of 1 ft (0.3 m). An example detail is shown in Figure 5-11.

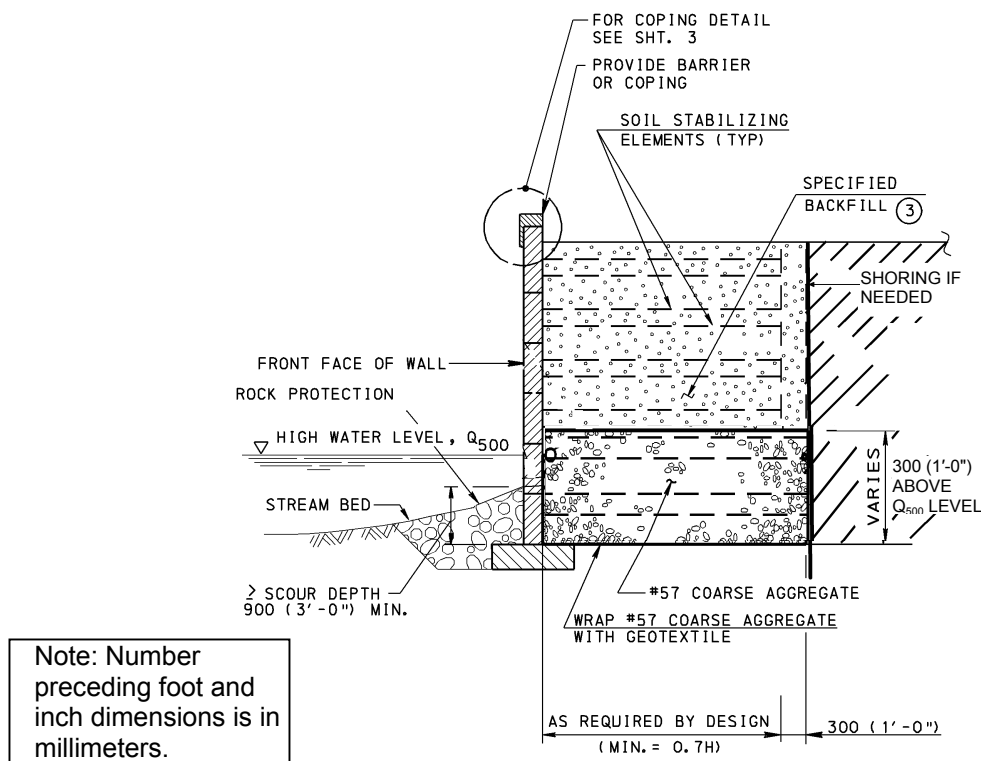

Figure 5-11. Example detail for wall that may experience inundation.

5.3.2 External Drainage

Surface drainage is an important aspect of ensuring MSE wall performance and must be addressed during design. Appropriate measures to prevent surface water from infiltrating into the wall backfill should be included in the design of all MSE walls. This typically requires coordination with designers of other project elements.

During construction of an MSE wall, the Contractor should grade the wall fill surface away from the wall face at the end of each day of construction to prevent water from ponding behind the wall and saturating the soil. In addition to softening the subgrade, surface water running onto a partially completed wall fill can carry fine-grained soils into the backfill work area and locally contaminate a free-draining granular backfill with fines. If finer grained backfill is being utilized for the reinforced wall fill, saturation can cause movements of the partially constructed wall.

When possible, finished grading at the top of a wall structure should provide positive drainage away from the wall to prevent or minimize infiltration of surface water into the reinforced wall fill. If the area above the wall is paved, a curb and gutter is typically used to direct the flow away from the wall. Drainage swales lined with concrete or asphalt can be used to collect and discharge surface water. Vegetation lined swales may be used where a vegetated finished grade slopes to the wall. Water runoff over the top of a wall where the backfill slopes towards it can lead to erosion behind the top of the wall and undermining of the wall. Such runoff can also cause staining of the wall face as soil is carried with the water. Construction of a collection swale close to the wall will help to prevent runoff from going over the top of the wall. Runoff flow will concentrate at grading low points behind the face and cause ponding which leads to undesirable infiltration of water into the backfill and increased compressibility due to softening of the backfill.

Collection and conveyance swales should prevent overtopping of the wall for the design storm event. Extreme events such as heavy rainfalls of short duration have been known to cause substantial damage to earth retaining structures due to erosion and undermining, flooding, and/or increased hydrostatic pressures both during and after construction. This is particularly true for sites where surface drainage flows toward the wall structure and where finer-grained backfills are used.

If the surface grading is such that there is likelihood of surface water flowing towards an MSE structure, then the water should be collected in a gutter or other collection feature that is part of the site drainage features. Such site drainage features are designed for an assumed or prescribed design storm event. For MSE walls, the design storm event should be based on a minimum 100 year event. However, extreme events can occur that result in short duration flows, e.g., 1 to 3 hours, which significantly exceed the design capacity of the stormwater management system. When such events occur, site flooding can cause overtopping of the wall, erosion and undermining, and an increase in hydrostatic forces within and behind the reinforced soil mass. Therefore, the site layout and wall structure should include features for handling flows greater than the design event as is typically done in the design of an overflow spillway for a dam. The project civil engineer should address potential excess flows and coordinate work with the wall designer. Consideration should be given to incorporating details of overflow features, such as a spillway, into the wall design for sites where surface water flows towards the wall structure. An example of an overflow feature is shown in Figure 5-12. Maintenance issues included in Section 5.3.4 should be addressed to ensure that all site drainage features are performing adequately.



Figure 5-12. Example MSE wall overflow sill at top of wall.

Drainage Swale at Top of Wall

A drainage swale is a man-made depression in the ground surface used to intercept surface water and direct it in a controlled manner to an outlet. Drainage swale can also be used to reduce the potential for surface water from overtopping the wall. Figure 5-13 shows typical drainage swale details for segmental precast concrete facing and modular block wall facing units. When a drainage swale is used, the project civil engineer and the wall designer should address and detail the outlet(s) for the swale. For example, the swale can be detailed to discharge water at the end of the wall structure or to low overflow points along the wall length. Overflow points should be detailed on the construction drawings. The designer should anticipate and address in design and detailing the possibility of water runoff from extreme events which will overtop the drainage swale and run down the wall face, unless the swales are specifically sized for such events. For sloping backfills, the wall designer should also address collection and diversion of water at the top of the slope. Site water runoff from above the backslope should not be directed toward the MSE wall backslope.

Vegetated swales as shown in Figure 5-13b can provide an aesthetically pleasing appearance. However, the effectiveness of the low permeability soil in preventing water from migrating into the reinforced soil mass and drainage aggregate should be evaluated. Shrinkage cracks in the low permeability soil during periods of extended dry weather may increase the permeability of the layer to the extent that it is no longer an effective barrier layer. Therefore, a geomembrane should be used beneath any vegetated swale.

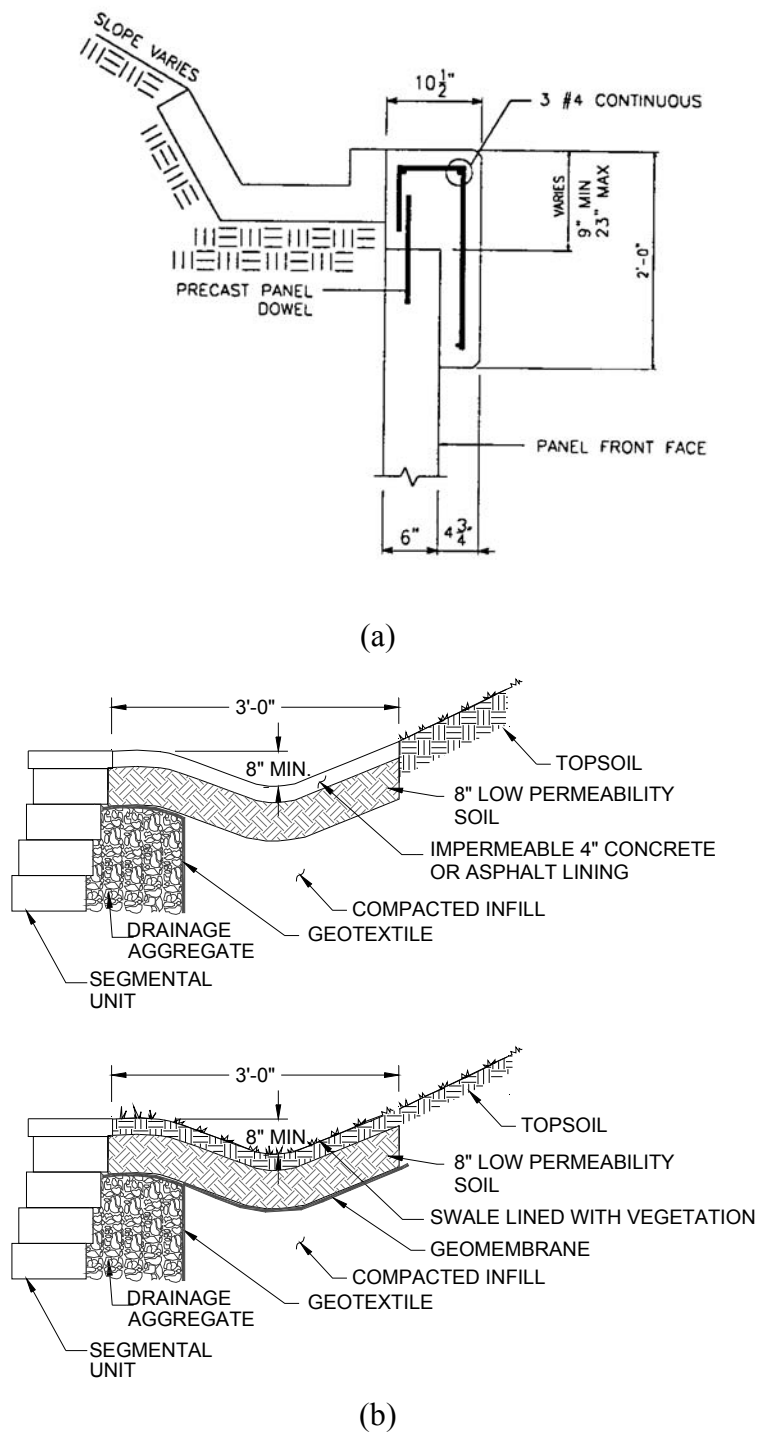

Figure 5-13. Example drainage swale near top of wall. ((b) Collin et al., 2002).

Geomembrane Barriers

A geomembrane barrier can be used to prevent surface water infiltration and associated seepage forces that can occur when using poorly draining reinforced fill. In addition steel soil reinforcements in the upper portion of MSE walls exposed to runoff containing deicing salts are affected by higher corrosion rates than defined by current corrosion rate models. Therefore, a geomembrane barrier should be placed below the road base and just above the first layer of soil reinforcement. The geomembrane should be tied into a drainage system to collect and discharge the runoff. As per Article 11.10.8 of AASHTO (2007), a roughened surface PVC, HDPE or LLDPE geomembrane with a minimum thickness of 30 mils (0.75 mm) should be used. All seams in the membrane should be glued or welded to prevent leakage.

An example detail for use of geomembrane barrier to prevent infiltration of runoff into the reinforced soil mass is illustrated in Figure 5-14a. As shown in Figure 5-14a, the geomembrane should be sloped to drain away from the facing to an intercepting longitudinal drain outletted beyond the reinforced mass. Installation of a geomembrane infiltration barrier is shown in Figure 5-14b and 5-14c. Design requirements for the geomembrane are covered in Section 5.3.3.

Pavement Permeability and Runoff

Pavements are porous structures. Surface water flows through asphalt pavement cracks and concrete joints and cracks into the pavement base material(s). The flow into the base aggregates can be significant, with up to 50% of the water falling on the pavement finding its way to the base course, and much more if there are cracks in the pavement, e.g., upwards of 97% will flow through a 1/8 in. (3 mm) crack according to AASHTO (1986). This water then saturates the subgrade because the relatively high permeability base aggregate ponds the water above the MSE wall. The situation is compounded if the site and pavement grades toward a low spot as shown in Figure 5-15. The MSE wall designer should interact with the project civil engineer to ensure that such a condition is mitigated and positive drainage measures are provided to capture the pavement drainage in the form of proper grading away from the wall and edge drains. Consideration should also be given to using the geomembrane detail shown in Figure 5-14, to intercept and discharge the water seeping through cracks in the pavement.

Surface runoff on the pavements that overtops the wall can cause undermining of the wall. Sloping the roadway towards a ditch is a common way to guard against wall overtopping. This is also sometimes referred to as roadway "in sloping."

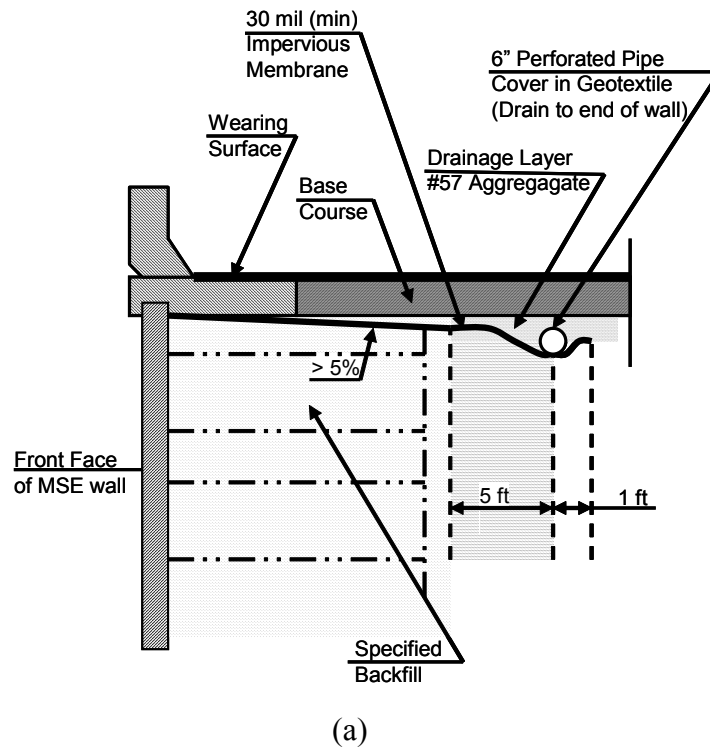

(b)

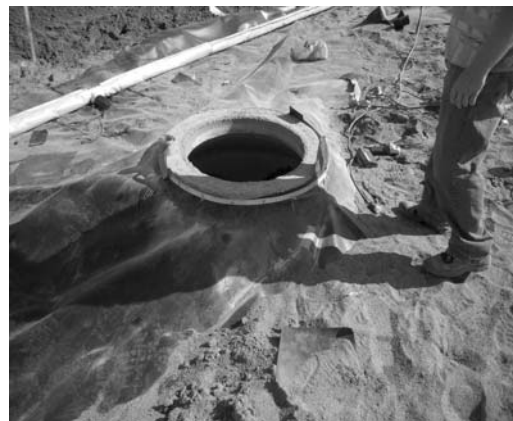

(c)

Figure 5-14. (a) Example geomembrane barrier details, (b) Installation of geomembrane deicing salt runoff barrier, (c) Geomembrane installation around manhole penetration.

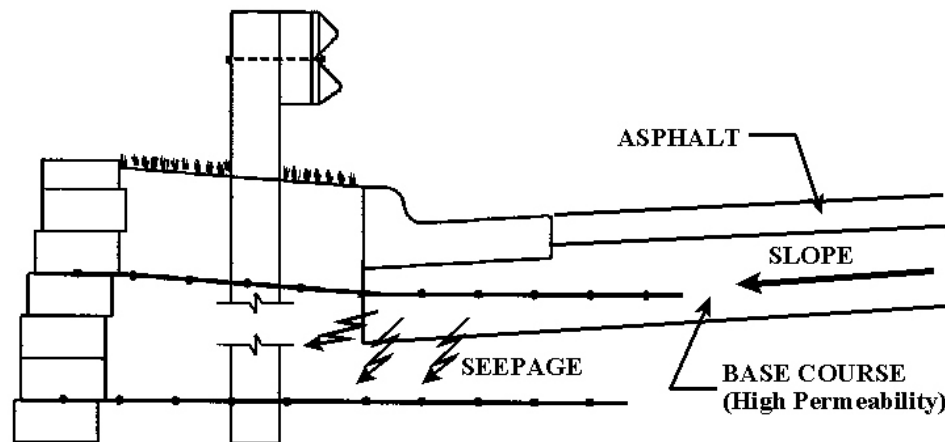

Figure 5-15. Example of undesirable water seepage through pavement due to deficient grades (Collin et al., 2002)

Grade at Toe and Ends of the Wall

The final grade at the toe and ends of the wall, both as designed and as constructed, is an important consideration for water flow conditions. Surface water flow along the toe of a MSE wall may occur around the ends or along the face of the structure and has the potential to erode the soil. An example of water damage is shown in Figure 5-16. Erosion of soil at the toe of a wall eventually may undermine the MSE wall facing units. Thus, design and construction details normally should direct flow away from the toe of wall structures. This can be accomplished with site grading and with a soil berm or slope at the toe of the wall.

Erosion control details are required where water will flow adjacent to the wall toe. Geotextile lined riprap stone or other means should be used to prevent scour. The designer also may elect to embed the wall deeper (i.e., lower foundation level) where the potential for erosion of the wall toe exists. Consideration should be given to turning the wall 90 degrees inward from the face.

The ends of the wall that terminate in or intercept embankment slopes should also be protected from erosion. Walls that terminate in slopes should be adequately keyed into the slope and a swale used to divert water away from the ends of the wall to mitigate erosion. Wing walls for approach fills should also be design such that water does not flow down the slope along the back of the wall face. Again a swale can be used to divert water and the surface of the slope should be graded to promote water flows away from the wall.



Figure 5-16. Example of surface flow erosion at the bottom of an MSE wall.

5.3.3 Filtration and Drainage System Component Requirements

Construction of an MSE wall may involve several types of soils. Groundwater flow from one soil type to another, and then to a drain and outlet feature, should be unimpeded. Soil filtration and permeability requirements must be met between adjacent zones of different soils to prevent impeded flow or piping. Adjacent soils of interest in an MSE wall system are as follows:

- the reinforced fill and any drainage layers,
- the reinforced fill, facing elements such as joints and/or face drainage aggregate and geotextile covering the joints,
- the reinforced fill and retained fill,
- the reinforced fill and foundation soil, and
- the reinforced fill and embankment fill above the wall and low permeable surface fill that may be used to reduce infiltration.

Filters may be in the form of a graded granular soil or a geotextile. Design of both soil filters and geotextile filters are discussed below. Design of geocomposite drains, drainage inflow and outflow, drain collection and outlet pipes and geomembrane barriers are also discussed.

Soil Filters

As water flows from one soil zone to another, the downstream soil must meet filter criteria to prevent piping of the upstream soil. Furthermore, the downstream soil must have adequate permeability relative to the adjacent, upstream soil. Therefore, the downstream soil must have the correct gradation range to function properly as a filter. The gradation requirements of the filter are also a function of the upstream soil gradation because the design flow capacity of the filter cannot be realized if the upstream soil pipes into the downstream soil. The pore sizes in the filter soil must be small enough to retain the larger size particles of the soil, which in turn retain the smaller sizes of the retained soil. The filter pore size is mathematically a function of its controlling particle size.

Design criteria for soil filters are summarized below and are based upon gradations of two adjacent soils. The particle sizes used in design are the D_{15} , D_{50} , and D_{85} sizes (subscript denotes the percentage of material, by weight, which has a smaller diameter). These criteria are applicable to adjacent soils with gradation curves that are approximately parallel. The equations are not applicable to gap-graded soils, soil-rock mixtures, non steady-state flow and soils with gradation curves that are not approximately parallel. When criteria are not applicable, filter design should be based upon laboratory filtration tests. The reader is referred to Cedergren (1989) for a comprehensive discussion on soil filtration.

The soil filtration criterion to prevent piping (i.e., retention) of the upstream soil into the filter is:

$$\frac{D_{15}(\text{filter})}{D_{85}(\text{soil})} < 5 \quad (5-1)$$

To ensure sufficient permeability of the filter material, the ratio of the filter D_{15} to the upstream soil D_{15} should be as shown in Equation 5-2.

$$4 < \frac{D_{15}(\text{filter})}{D_{15}(\text{soil})} < 20 \quad (5-2)$$

An additional criterion to prevent movement of soil particles into or through filters is presented in Equation 5-3. For CL and CH soils without sand or silt particles, the D_{15} size of the filter in Equation 5-2 may be as great as 0.016 in, and Equation 5-3 may be disregarded. However, if the upstream soil, i.e., retained fill or backcut soils, contains particles of uniform non-plastic fine sand and silt sizes, the filter must be designed to meet these criteria.

$$\frac{D_{50(\text{filter})}}{D_{50(\text{soil})}} < 25 \quad (5-3)$$

Geotextile Filters

A geotextile is often used as a filter between a finer-grained and a more permeable soil. The geotextile must retain the finer-grained soil, while allowing water to readily pass into the more permeable soil, and function throughout the life of the earth retaining structure. Thus, geotextile design must address retention, permeability, and clogging. The geotextile must also survive the installation process.

The following design steps are from the FHWA Geosynthetic Design and Construction Guidelines Manual (Holtz et al. 2008).

- Step 1. Determine the gradation of the material to be separated/filtered. The filtered material is directly upstream or downstream of the geotextile filter for the drainage layer. Determine D_{85} , D_{15} , $C_u = D_{60}/D_{10}$ and the percent passing a No. 200 (0.075 mm) sieve. When the soil contains particles 1 in. (25 mm) and larger, use only the gradation of soil passing the No.4 (4.75 mm) sieve in selecting the geotextile (*i.e.*, scalp off the + No.4 (+4.75 mm) material).
- Step 2. Determine the permeability of the upstream or downstream material to be filtered. These include the reinforced fill, foundation soil, retained fill and the natural soil in cut slope.
- Step 3. Apply design criteria for retention, permeability and clogging resistance to determine apparent open size (AOS), permeability (k), and permittivity (ψ) requirements for the geotextile (after Holtz et al., 2008). AOS, k and ψ of the candidate geotextile are determined from standard ASTM tests and is typically the value published by the geotextile manufacturers/suppliers. Use only needlepunched nonwoven or monofilament woven geotextiles (*i.e.*, slit film woven geotextiles shall not be used).

A. Retention Criteria – Steady State Flow

Using the D_{85} and C_u values from Step 1, determine the largest allowable pore size as follows:

$$\text{AOS} \leq B D_{85} \quad (5-4)$$

where:

AOS = apparent opening size of the geotextile

- B = dimensionless coefficient
 D_{85} = soil particle size for which 85% are smaller

The AOS value of the candidate geotextile is determined from the results of the ASTM D4751 test method, and is typically the value published by the geotextile manufacturers/suppliers. The B coefficient ranges from 0.5 to 2 and is a function of the upstream finer-grained soil, type of geotextile, and/or the flow conditions. For sands, gravelly sands, silty sands and clayey sands (i.e., sands with less than 50% passing the No. 200 sieve), B is a function of the uniformity coefficient, C_u ($C_u = D_{60}/D_{10}$), of the upstream soil. Table 5-1 presents values of B for various values of C_u .

If the upstream soil contains any fines, only the portion passing the No. 200 sieve should be used for selecting the geotextile. For silts and clays (more than 50% passing the No. 200 sieve), B is a function of the type of geotextile as given in Table 5-2.

These retention criteria are for internally stable soils and steady-state seepage conditions. Laboratory performance tests should be conducted for unstable soils. For soils with a $C_u > 20$, unsteady seepage may occur. For dynamic and cyclic flow condition use $AOS < 0.5D_{85}$. See Holtz et al. (2008) for further information on dynamic flow conditions such as wave action.

**Table 5-1. Values of B for Various C_u Values
for Soils with Less than 50% Passing the No. 200 Sieve.**

C_u	B
$C_u \leq 2$	1
$2 \leq C_u \leq 4$	$0.5 C_u$
$4 < C_u < 8$	$8 / C_u$
$C_u \geq 8$	1

**Table 5-2. Values of B and AOS for Soils with
More than 50% Passing the No. 200 Sieve Based on Type of Geotextile.**

Type of Geotextile	B	AOS
Woven monofilament	B = 1	$AOS \leq D_{85}$
Nonwoven	B = 1.8	$AOS \leq 1.8D_{85}$
Both woven and nonwoven	-	$AOS \leq 0.012$ in. (0.3 mm)

B. *Permeability/Permittivity Criteria*

For steady-state flow, low hydraulic gradient and well graded or uniform upstream soil, the permeability and permittivity criteria are:

- For permeability $k_{\text{geotextile}} \geq k_{\text{soil}}$ (Less Critical / Less Severe) (5-5a)
 $k_{\text{geotextile}} \geq 10 k_{\text{soil}}$ (Critical / Severe)

- For permittivity $\Psi \geq 0.5 \text{ sec}^{-1}$ for < 15% passing No. 200 sieve (5-5b)

- $\Psi \geq 0.2 \text{ sec}^{-1}$ for 15% to 50% passing No. 200 sieve (5-5c)

- $\Psi \geq 0.1 \text{ sec}^{-1}$ for > 50% passing No. 200 sieve (5-5d)

where:

k = coefficient of permeability (or hydraulic conductivity) and

Ψ = geotextile permittivity, which is equal to $k_{\text{geotextile}}/t_{\text{geotextile}}$.

Critical or severe applications are described in Holtz et al. (2008) and, as indicated in Equation 5-5a, a geotextile permeability of 10 times the soil permeability should be used. The geotextile permittivity is determined from the results of the ASTM D4491 test method.

C. *Clogging Criteria*

- a. For steady state flow, low hydraulic gradient and well graded or uniform upstream soil, the clogging criterion is:

$$\text{AOS} \geq 3 D_{15(\text{upstream soil})} \quad (5-6)$$

This equation applies to soils with $C_u > 3$. For soils with $C_u \leq 3$, a geotextile with the maximum AOS value from the retention criteria should be used.

- b. Other qualifiers

Nonwoven geotextiles: Porosity (geotextile) $\geq 50\%$

Woven geotextiles: Percent open area $\geq 4\%$

- c. Alternative: Run filtration tests, especially for critical and severe applications

Step 4. In order to perform effectively, the geotextile must also survive the installation process. AASHTO M288 (2006) provides the criteria for geotextile strength required to survive construction of roads, as shown in Table 5-3. Use geotextile Class 2 where a moderate level of survivability is required (e.g., for geotextile filters at the wall face and on back drains). Class 1 geotextiles are recommended when heavy construction equipment is used and/or angular fill will be placed directly above or below the geotextile (e.g., geotextile filters for base drains). A minimum of 6 in. (150 mm) of base/subbase should be maintained between the wheel and geotextile at all times.

Table 5-3. Geotextile Survivability Requirements (AASHTO M 288, 2006).

Test	Test Method	Units	Geotextile Class			
			Class 1		Class 2	
			< 50%*	≥ 50%*	< 50%*	≥ 50%*
Grab Strength	ASTM D4632	N (lb)	1400 (315)	900 (200)	1100 (250)	700 (157)
Seam Strength	ASTM D4632	N (lb)	1200 (260)	810 (180)	990 (220)	630 (140)
Tear Strength	ASTM D4533	N (lb)	500 (110)	350 (80)	400 (90)	250 (56)
Puncture Strength	ASTM D6241	N (lb)	2750 (620)	1925 (433)	2200 (495)	1375 (309)
Ultraviolet Stability (Retained Strength)	ASTM D4355	%	At face joints - 70% after 500 hours of exposure Buried in wall - 50% after 500 hours of exposure			
*Note: Elongation measured in accordance with ASTM D4632 with < 50% typical of woven geotextiles and ≥ 50% typical of nonwoven geotextiles. (1 N = 0.22 lbs, 1 kPa = 0.145 psi)						

Step 5. Collect samples of geotextile, reinforced fill and retained fill at time of construction to confirm acceptance.

Step 6. Monitor installation during construction.

Step 7. Observe effectiveness of drainage system during and after storm events.

For a more thorough treatment of geotextile drains see Holtz et al. (2008).

Geocomposite Drain

A geocomposite, or prefabricated, drain consists of a geotextile filter and a water collection and conveyance core. The cores convey the water and are generally made of plastic waffles, three-dimensional meshes or mats, extruded and fluted plastic sheets, or nets. A wide variety of geocomposites are readily available. For MSE wall design, only geocomposites that allow two-sided flow (i.e., flow into the drains from both sides) should be used. However, the filtration and flow properties, detailing requirements, and installation recommendations vary and may be poorly defined for some products. The geotextile of the geocomposite should be designed to meet filter and permeability requirements discussed previously in this section. The flow capacity of geocomposite drains can be determined by using the procedures described in ASTM D4716. Long-term compressive stresses and eccentric loadings on the geocomposite core should be considered during design and selection.

MSE walls can place a significant stress on the geocomposite. Hence, the design pressure on a geocomposite core should be limited to either of the following:

- the maximum pressure sustained on the core in a test of 10,000 hr minimum duration; or
- the crushing pressure of a core, as defined with a quick loading test, divided by a safety factor of five.

Finally, as with in drain system, consideration should be given to system performance factors such as distance between drain outlets, hydraulic gradient of the drains, potential for blockage due to small animals, freezing, etc. Other design aspects of geocomposite drains are addressed in Holtz et al. (2008).

Installation details, such as joining adjacent sections of the geocomposite and connections to outlets, are usually product-specific. Product-specific variances should be considered and addressed in the design, specification, detailing and construction phases of a project. General construction specification requirements will be review in Chapter 10. Post installation examination of the drainage core/path with a camera scope should be considered for critical applications.

Drainage Inflow and Outflow Design Requirements

For proper design of the drains at the back or base of the reinforced soil mass, the flow into the system and the flow in the drain must be evaluated. These flow conditions are discussed below and apply to either gravel or geocomposite drains. Cedergren (1989) and Huntington (1957) present a more thorough treatment of pressures induced by the influence of ground water and seepage acting on retaining walls as well as drainage design.

Flow into the System. Anticipated flow into the drain system may be estimated using Darcy's Law. Flow is equal to:

$$q = k i A \quad (5-7)$$

where:

- q = infiltration rate
- k = effective permeability of retained backfill soil
- i = average hydraulic gradient in retained backfill soil
- A = area of soil normal to the direction of flow

Conventional flow net analysis can be used to calculate the hydraulic gradient.

Some drains consist of drainage aggregate surrounding a perforated pipe with a filter (usually a geotextile) surrounding the drainage aggregate. Flow into the drainage aggregate may be calculated with Equation 5-7. Flow from the drainage aggregate into the pipe is through the circular or slot perforations. Perforated, corrugated HDPE pipe is manufactured with minimum inlet openings of approximately 1 square inch per 1 foot length (20 cm² per meter length) for standard pipe (AASHTO M252, 2006). Standard pipe is generally adequate for most subsurface drainage applications. Hole diameter or slot width must be checked relative to the size of the surrounding drainage aggregate, to ensure soil retention. For slots, Equation 5-8 may be used to check retention.

$$\frac{D_{85(\text{drain fill})}}{\text{Slot Width}} > 1.2 \text{ to } 1.4 \quad (5-8)$$

For circular perforations, Equation 5-9 may be used to check retention.

$$\frac{D_{85(\text{drain fill})}}{\text{Hole Diameter}} > 1.0 \quad (5-9)$$

Flow Capacity of the Drain. Flow capacity within aggregate drains can be estimated with Equation 5-7, using k and i for the soil drain material. Flow capacity within geocomposite drains is expressed in term of unit width using the following form of Darcy's Law.

$$q = \lambda i B \quad (5-10)$$

where:

- q = flow rate
- λ = transmissivity of geocomposite drain
- i = hydraulic gradient in drain
- B = width of geocomposite drain

The geocomposite transmissivity should be evaluated with an appropriate laboratory model test. Product long-term transmissivity should be quantified at anticipated (or greater) design pressure and over time to evaluate potential decrease of flow capacity due to creep (i.e., creep of geotextile into flow channel).

Flow Capacity of the Drain Pipe. Flow capacity within drain pipes, flowing full, can be computed with the Manning's equation. Flow is equal to:

$$q = \frac{0.463}{n} d^{8/3} s^{1/2} \quad (5-11)$$

where:

- q = flow rate (cfs)
- n = roughness coefficient, or Manning's value
- d = diameter of pipe (feet)
- s = slope of energy grade line (ft per ft)

Drain Collection and Outlet Pipes

Collection and outlet pipes are often used with the drain directly behind the facing units and with the drain at the back of the reinforced soil mass. Examples of such drains are shown in Figures 5-8 and 5-10. Pipes are generally laid at required slopes, with a minimum of 2% for constructability and to ensure positive flow. Outlets are generally spaced based on the flow capacity of the pipes or alternatively at 20 ft (6 m) to 50 ft (15 m) maximum lateral spacing, and protected as noted in a later discussion on maintenance. The outlet pipes should be solid and gravity flow (e.g., 2% minimum grade) to daylight or the storm drain system.

Geomembrane Barriers

Design and specification of a geomembrane as a deicing salt barrier must address installation requirements. A geomembrane must be capable of withstanding the rigors of installation to ensure the integrity of the barrier. The subgrade material, subgrade preparation, geomembrane placement method, overlying soil fill type, and placement and compaction of overlying fill soil all affect the geosynthetic barrier's survivability. Recommended properties of geomembrane barriers (Koerner, 1998) are presented in Table 5-4. A minimum thickness of 30 mils (0.75 mm) is recommended for geomembranes above MSE walls.

Three areas of construction which are critical to a successful installation are:

- subgrade preparation;
- handling/installation including field seaming; and
- sealing around penetrations and adjacent structures.

The subgrade must provide support to the geosynthetic barrier and minimal point loadings. The subgrade must be well-compacted and devoid of large stones, sharp stones, grade stakes, etc., that could puncture the geosynthetic barrier. In general, no objects greater than ½ in. (12 mm) should be protruding above the prepared subgrade (Daniel and Koerner, 1993).

Handling and installation specifications for geomembrane and other geosynthetic barriers should, as a minimum, conform to the manufacturer's recommendations. All seams in the membrane should be glued or welded to prevent leakage. Special project requirements for geomembranes should be noted in the construction specifications and plans.

Table 5-4. Recommended Minimum Properties for General Geomembrane Installation Survivability (after Koerner, 1998).

Property and test method	Required degree of survivability	
	Medium ¹	Very high ²
Thickness, mils (mm) – ASTM D5199 or ASTM D5994 for Textured	30 (0.75)	40 (1.00)
Tear (Die C), lbf (N) - ASTM D1004	10 (45)	20 (90)
Puncture, lbf (N) - ASTM D4833	32 (140)	45 (200)
NOTES: 1. <i>Medium</i> refers to placement on machine-graded subgrade with medium loads. Soil fill should have a maximum size of ¾-inch. 2. <i>Very high</i> refers to placement on machine-graded subgrade of very poor texture. Soil fill with maximum size greater than ¾-inch.		

Geomembrane selection should also consider installation details of attachment to the MSE wall facing and details around penetrations. Construction details around penetrations and adjacent structures depend upon the chosen geosynthetic material and the project design. As such, they must be individually designed and detailed. For example, batten strips and mechanical fasteners were used with the 30 mil (0.75 mm) thick HDPE geomembrane shown in Figure 5-14c. Geosynthetic manufacturers and waste containment manuals can provide design guidance.

Another design consideration may be the frictional resistance of the geomembrane. As per Article 11.10.8 of AASHTO (2007), typically, a roughened surface PVC, HDPE or LLDPE geomembrane with a minimum thickness of 30 mils (0.75 mm) should be used. Such roughened geomembranes are readily available in the marketplace.

5.3.4 Maintenance of Drainage

Features that minimize water flow into an MSE wall and features that preserve MSE wall drainage should be maintained over the life of the structure. For example, cracks in pavement above MSE walls should be sealed. Differential settlements and pavement cracks around catch basins should be corrected to minimize potential inflow into the reinforced soil or retained soil mass. These maintenance items are for non-wall features and the wall designer may have little influence on these items. However, in interacting with designers of other project features, the need to maintain items that potentially could affect the wall should be discussed.

One of the maintenance items that the wall designer has control over is the drain outlet(s). Screens should be installed and maintained on drainpipe outlets. Screening is used to prevent small animals from nesting in and clogging the pipe. Outlet screens and cleanouts to provide access to clogged drainage should be detailed on the retaining wall construction drawings.

Additional items should be detailed when outlets are located in a soil embankment beneath the MSE walls. Drains are not effective unless the outlets are maintained, i.e., not clogged. Outlets in soil embankments should drain onto a concrete (usually precast) apron and should be marked with a permanent metal fence post. The apron and post minimize the chance of the outlet being run over and crushed by mowers or covered in subsequent construction activities. The apron and post should be detailed on the wall construction drawings.

5.4 INTERNAL DETAILS

There are a number of internal details that must be properly designed and implemented to ensure that the MSE wall system performs in an acceptable manner over its design life. This section presents common internal details

5.4.1 Contact between Dissimilar Metals

Often, several different types of metallic elements such as steel piles and drain pipes are placed in the reinforced soil mass. The metals used in such elements are different than those used in steel reinforcements. Corrosion can occur when dissimilar metals come in contact with each other due to galvanic action. Therefore, all steel soil reinforcements should be separated from other metallic elements by at least 3 in. (75 mm).

5.4.2 Vertical Obstructions in Reinforced Soil Mass

Vertical obstructions are structures that are embedded in or extend vertically through the reinforced soil mass. Examples of vertical obstructions are a catch basin, grate inlet, sign foundation, bridge foundation, light poles, guardrail post, or culvert. **Under no circumstances, should any reinforcement be left unconnected to the wall face or arbitrarily cut/bent in the field to avoid the obstruction.** A review of any modification to the design to avoid an obstruction must be made and approved by the wall designer of record. Additional consideration must be given to obstructions that exert a load on the wall (e.g., deep foundations, overturning of signs and light poles). Such applications may require additional reinforcement and facing support to resist the local increase in lateral stress. Likewise, the wall may exert lateral earth pressure or vertical downdrag stress on the obstruction due to movement of the wall, the consequences of which to the obstruction design and performance must also be evaluated.

The best design is to adjust the location of the obstruction and/or the soil reinforcement so that there is no interference. In some cases, where interference between the vertical obstruction and the soil reinforcement is unavoidable, the design of the wall near the obstruction may be modified using one of the following alternatives.

Alternative 1 - Fit the soil reinforcement around the obstruction without cutting the soil reinforcement as shown in Figure 5-17. In this alternative, the facing units near the obstruction are fitted with extra facing connections such that soil reinforcing can be connected at locations away from the vertical obstruction. For example, as shown in Figure 5-17a, a 5 ft (1.5 m) panel that needs a 4-wire bar mat may be fitted with 8 clevis loop

connections and in the field the bar mat can be attached to any 4 consecutive clevis loops depending on the location of the vertical obstruction. Similarly, as shown in Figure 5-17b, a 5 ft (1.5 m) panel with the obstruction blocking 2 strip reinforcements, a strong back consisting of a galvanized steel angle can bridge across two panels. The strong back then allows the two displaced reinforcements to be attached to each side of the obstruction. Where soil reinforcements are not centered on the panel, eccentric load of the facing panel must be evaluated with respect to the structural capacity of the face to resist increased bending moments and the potential for face rotation.

In case of strip reinforcements with a nut and bolt connection, it may be possible to splay the reinforcements around the obstruction as shown in Figure 5-17c. In such cases, the splay angle should be less than 15-degrees and the tensile capacity of the splayed reinforcement shall be reduced by the cosine of the splay angle. The splay angle is defined as the angle measured from a line perpendicular to the wall face in a horizontal plane. Due to the clevis loop or similar connection for bar mats splaying at more than 3- to 5-degrees is not possible without introducing moments at the connection and uneven loading of the clevis loop connectors. Under no circumstances should a bar mat be cut to force longitudinal wires around the vertical obstruction because it creates damaging moments on the cross bar welds as well as at the facing connection and cracking of galvanization. Bar mats should not be splayed if the connection mechanism does not accommodate such splay without cutting of cross bars.

If the soil reinforcements are navigated around the vertical obstruction, then care must be taken to balance forces in the wall face to assure that the wall panels do not rotate outward. Facing units with a joint in front of the vertical obstruction may be structurally connected across the joint as shown in Figure 5-17, or a longer panel may be considered, e.g., 10 ft (3 m) instead of 5 ft (1.5 m) wide panel. The structural connection should not extend across more than one joint, i.e., 2 panels. If such a condition occurs, then Alternatives 2 and 3 should be implemented as appropriate.

Alternative 2 - Assuming that reconfiguration of soil reinforcements as per Alternative 1 is not possible and the reinforcement layers must be partially or fully severed in the location of the obstruction, the surrounding reinforcement layers should be designed to carry the additional load which would have been carried by the severed reinforcements.

In this alternative, the portion of the wall facing in front of the obstruction should be made stable against a toppling (overturning) or sliding failure.

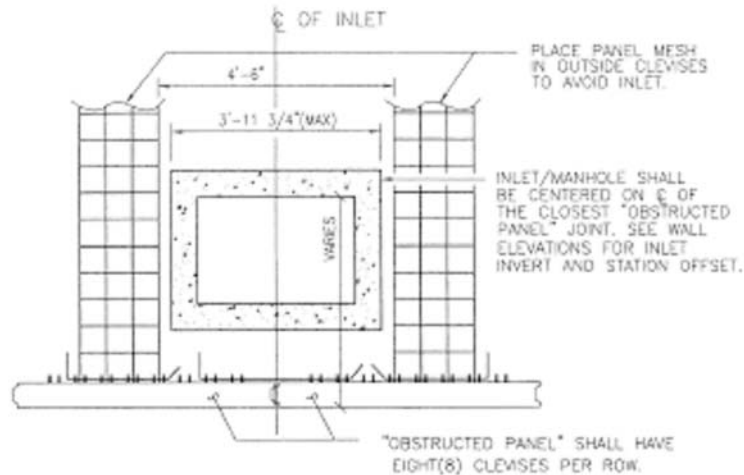

(a)

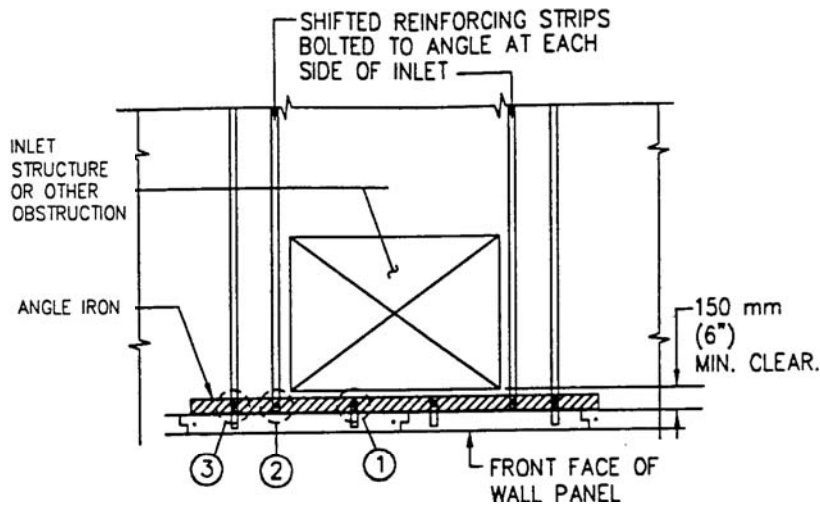

(b)

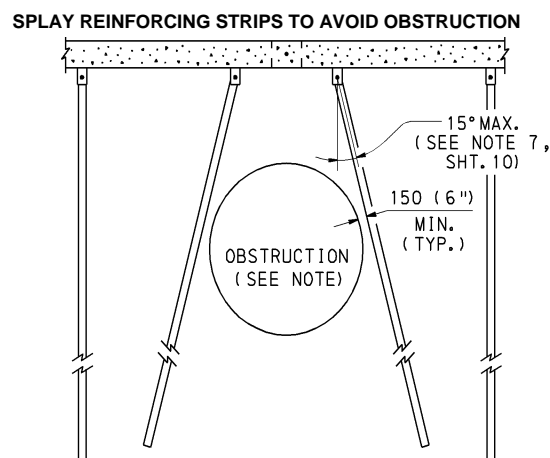

(c)

Figure 5-17. Examples of avoiding a vertical obstruction without severing soil reinforcements.

Alternative 3 - A structural frame can be placed around the obstruction which is capable of carrying the load from the facing in front of the obstruction to reinforcement connected to the structural frame behind the obstruction. This is illustrated in Figure 5-18a and 5-18b and in Figure 5-19. The structural frame and connections should be designed in accordance with Section 6 (“Steel Structures”) of AASHTO (2007) for the maximum tension at any level of reinforcements within the reinforced soil mass. The structural frame should be designed such that moments in the soil reinforcement or connection at the wall face are not generated.

Note that as shown in Figure 5-18c it may be feasible to connect the soil reinforcement directly to the obstruction depending on the reinforcement type and the nature of the obstruction. Figure 5-20 shows example details for MSE walls with modular block units with limited height vertical obstructions such as catch basin or fence post foundations near the wall face.

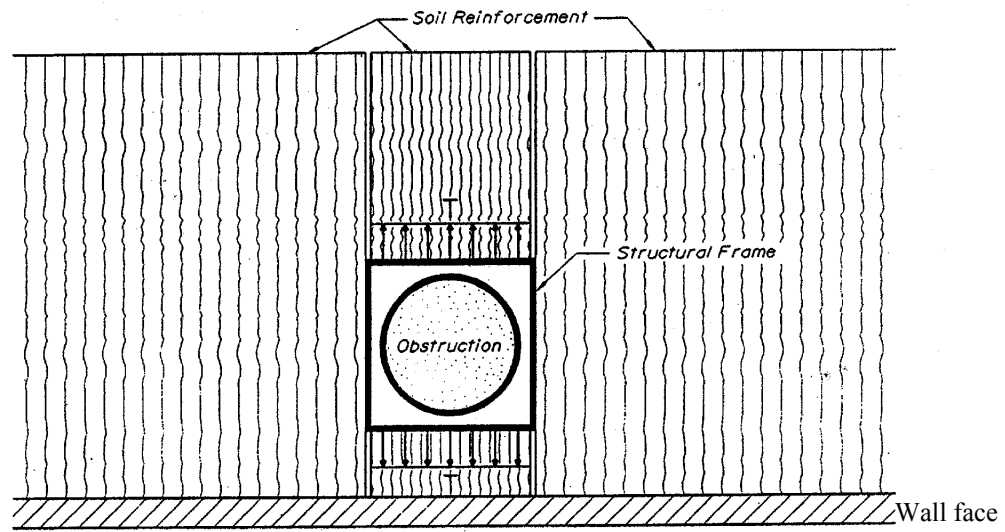

$T = \text{Total Load which Structural Frame must carry.}$

(a)

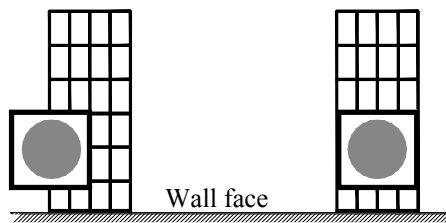

(b)

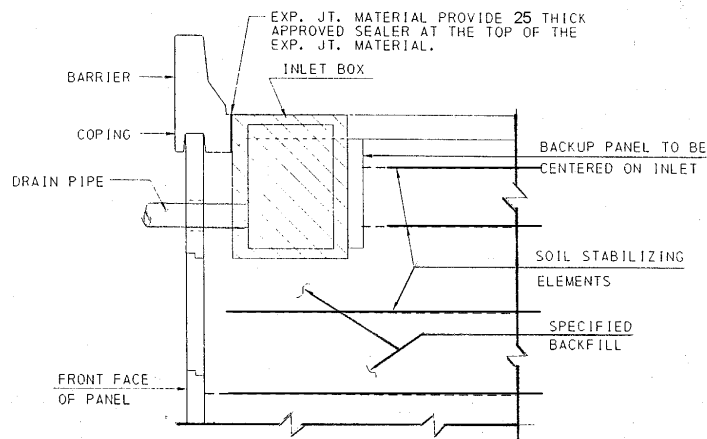

(c)

Figure 5-18. Vertical obstructions in reinforced soil mass with segmental precast facing units.



(a)



(b)



(c)

Figure 5-19. Example of a structural frame around vertical obstruction (a) with segmental precast facing - note that vertically adjacent layers of reinforcement to be separated by a minimum of 3-in. (75 mm) of wall fill, (b)-(c) with modular block face – note corner detail.

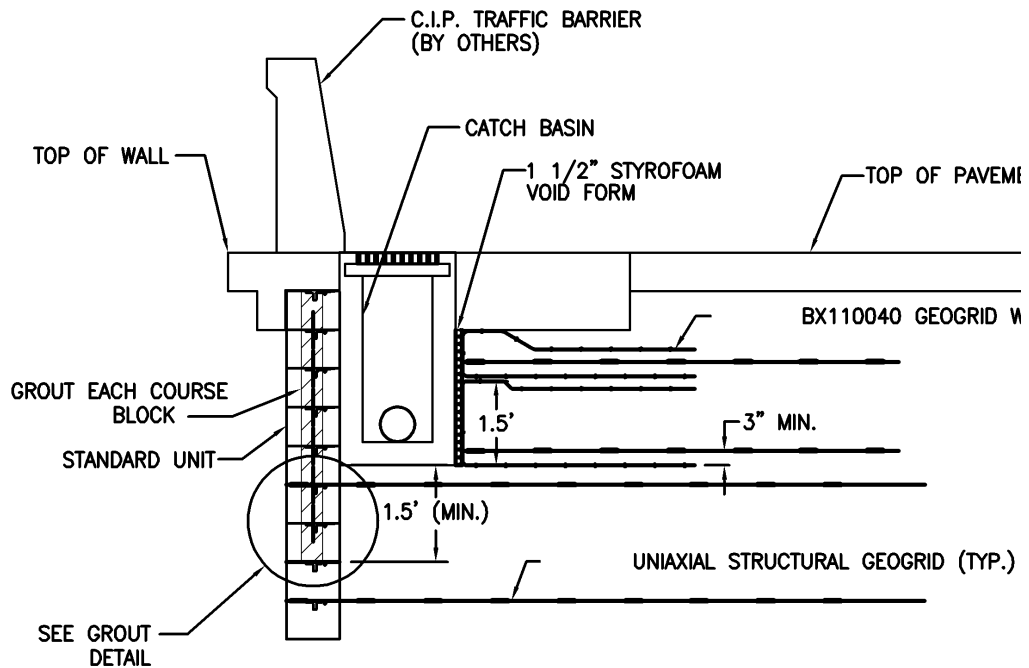

(a)

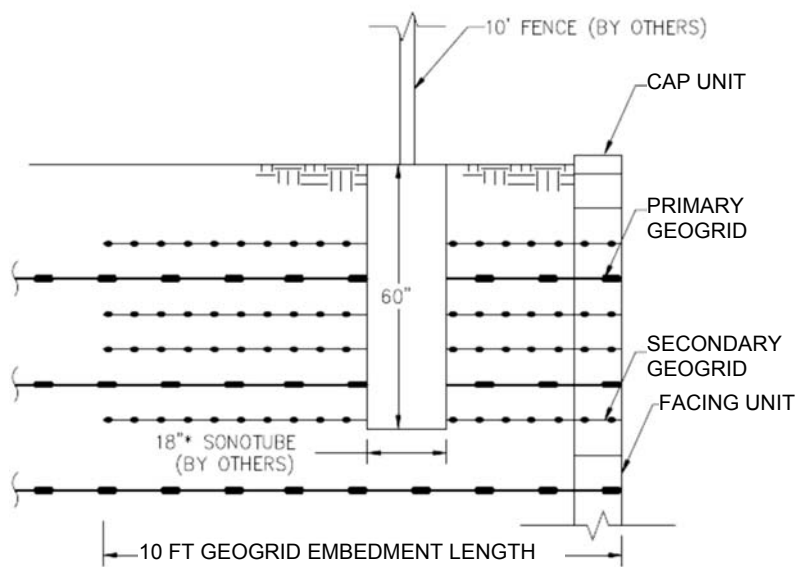

(b)

Figure 5-20. Example details of reinforcements around vertical obstructions in reinforced soil mass with modular block units.

5.4.3 Horizontal Obstructions in Reinforced Soil Mass

Horizontal obstructions are structures which are embedded in or extend horizontally through the reinforced soil mass for a substantial length along the wall. The horizontal obstructions are commonly due to utilities such as storm drain pipes. **Horizontal obstructions in reinforced soil mass should be avoided because not only do they create construction problems but obstructions such as utility pipes can be very expensive to repair and maintain as it may require dismantling the wall system.** If horizontal obstructions cannot be avoided, then some considerations for design are provided below:

- For inextensible reinforcements, the horizontal obstruction may be avoided if it is possible to deflect the reinforcement in a smooth manner up to 15 degrees of vertical skew as shown in Figure 5-21. Deflections greater than 15 degrees tend to break the galvanization and may reduce the tensile and pullout resistance of the inextensible soil reinforcements.
- Guidance for extensible reinforcements such as geogrids is presented in Figure 5-22.
- In cases where it is not possible to orient the reinforcements as shown in Figures 5-21 and 5-22, use of back-up panels may be considered as shown in Figure 5-23.
- It is not recommended to tie the reinforcements to pipes. Special details must be developed to accommodate the obstruction without attaching to it.
- Utility pipes in the reinforced mass are likely to settle differentially as the fill settles during construction. Downdrag stress should be anticipated where pipes intersect the wall face or a vertical structure such as a drop inlet. Significant leakage of water into MSE walls has been known to create wall problems including failures. Therefore, utilities should only be placed in double wall design systems such as locating utilities inside box culverts with inspection galleries or using double wall pipe with instrumentation to indicate leakage. Only leak proof joints should be used on drainage pipes. Where differential movement and downdrag stresses are anticipated, flexible connections should be used and designed to tolerate the estimated movement and stress.
- Pressurized water mains should not be constructed within an MSE structure.

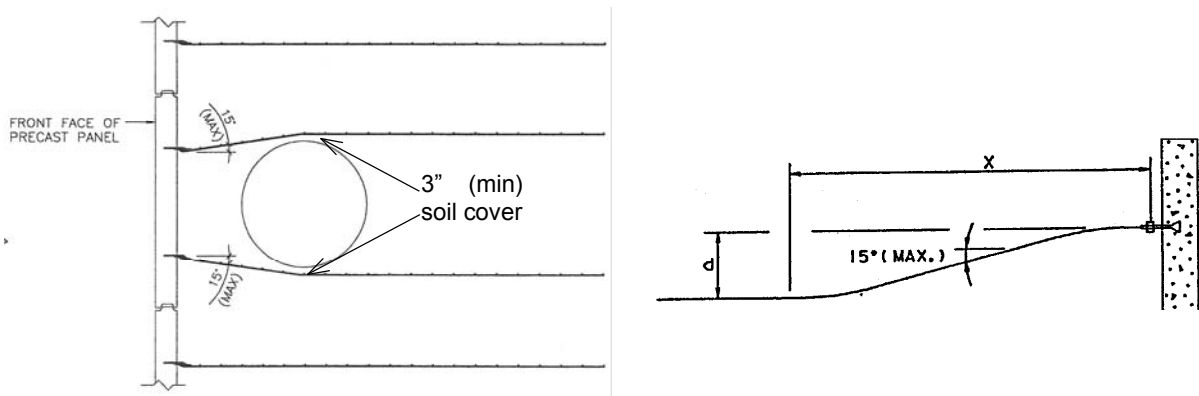

(a)

Additional depth (d) required, in.	Required minimum distance (X) to achieve smooth bend, in.
3	27
6	39
9	48
12	60
15	72

Figure 5-21. Navigating horizontal obstruction in MSE walls with inextensible reinforcements.

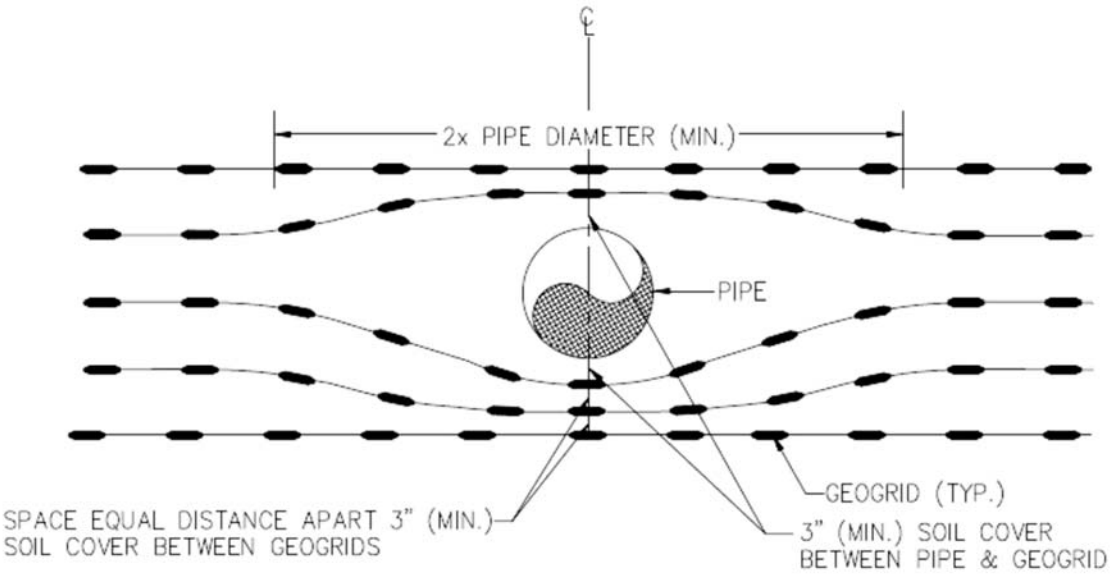

Figure 5-22. Navigating horizontal obstruction in MSE walls with extensible reinforcement.

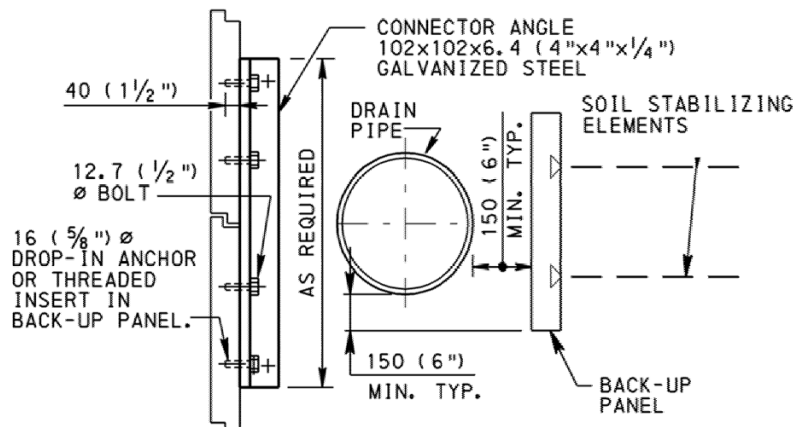

Figure 5-23. Example of backup panels for large horizontal obstructions.

5.4.4 Wall Face Penetrations

In some cases, pipes must penetrate the MSE wall or pass through the retained wall fill. Penetrations through the reinforced soil and/or wall facing units maybe at skew or perpendicular angles from the wall face.

If a pipe must penetrate through the face of the wall, the wall facing elements should be designed to fit around the pipe such that the facing elements are stable and the wall backfill an not spill through the wall face where it joins the obstruction. Differential movement between the facing and reinforced fill should be anticipated and associated downdrag stress must be consider in the design. Therefore, dry packing around the pipe should be done after the wall is substantially complete. Common details for penetrations through segmental precast concrete and modular block facing units are shown in Figures 5-24 and 5-25, respectively. Not noted on these details are the bedding and backfill for the pipe. Granular bedding may be significantly more permeable than the reinforced fill and/or the retained backfill. In these cases, the pipe bedding is a potential conduit for bringing water to the MSE wall structure. Therefore, a headwall is required to at the end of the pipe to prevent water from entering the bedding. Potential flow should be addressed in the wall details. A clear flow path, with filtration criteria addressed, from the pipe bedding and backfill to the drainage aggregate should be detailed. Weep holes through the concrete face collar may be needed to drain the pipe bedding and backfill.

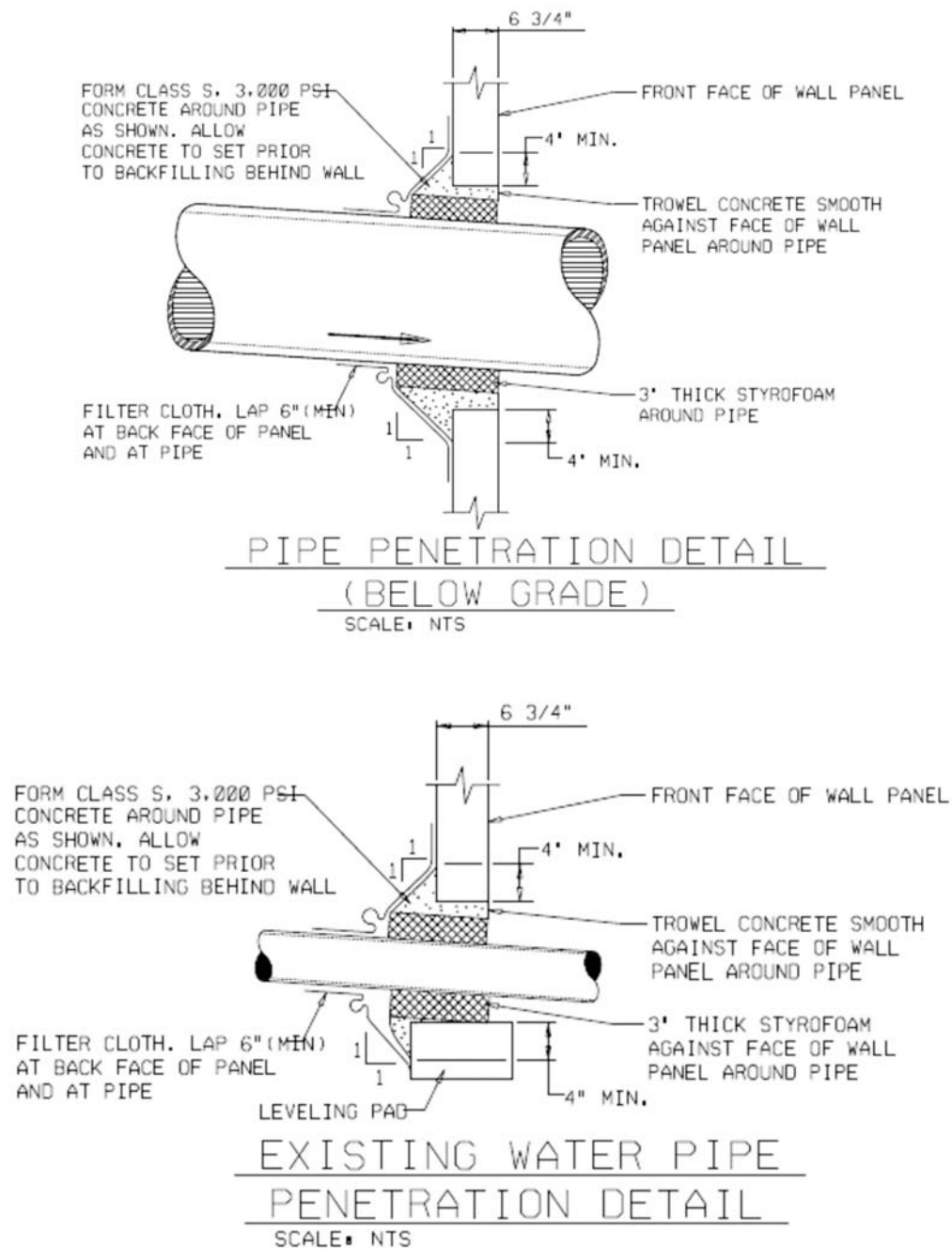

Figure 5-24. Example pipe penetrations through segmental precast panel facing units.

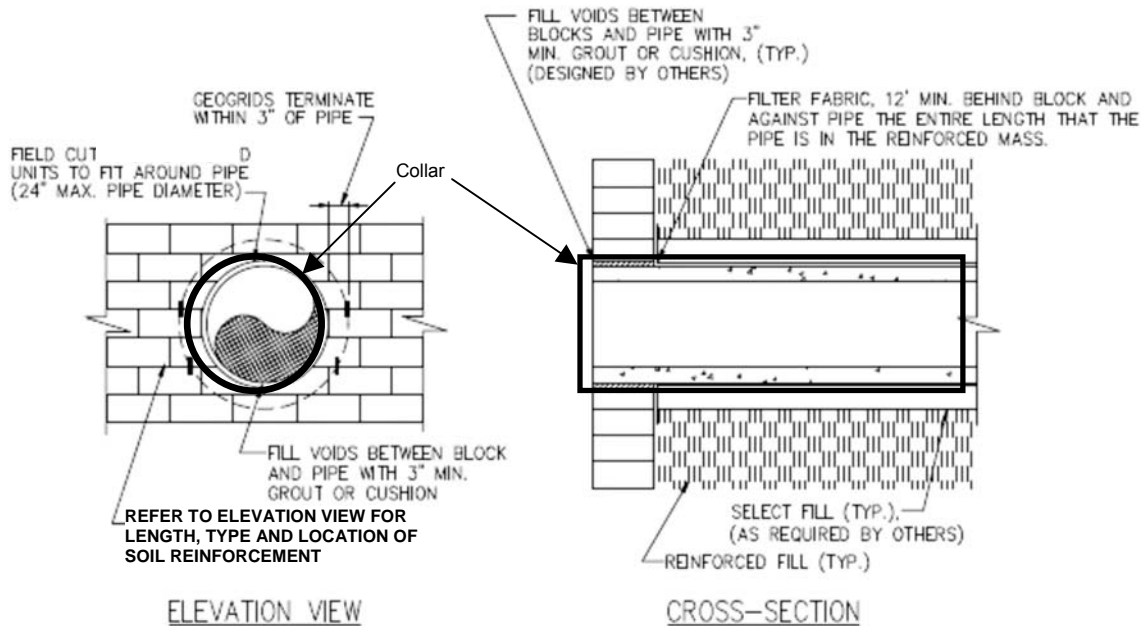

Figure 5-25. Example pipe penetration through modular block facing units.

Catch basins and manholes may penetrate vertically through the reinforced fill or retained backfill. The backfill around these manholes may be a granular soil. If the manhole backfill soils are more permeable than the wall fill soils, the manhole backfill is a potential conduit for water flow and collection. The wall designer should address this potential, as provided drainage if the surrounding wall fill soils are less permeable.

For critical wall structures, the wall designer may want to consider the possibility of leaking pipes saturating the surrounding soil. If this is a concern, a high permeability soil (relative to the wall fill) around the pipe leading to a drain or outlet may be used to provide a safety flow path.

5.4.5 Slip Joints

Where subsurface conditions and/or wall profile change abruptly, significant differential settlement may occur at the wall face with associated problems such as joint openings and facing unit to unit contact. In such cases, consideration may be given to use of slip joints which are continuous vertical joints. A slip joint is different than a regular vertical joint between panels in that there is a vertical separation between adjacent facing units that extends the full height of the wall. Due to this configuration of the joint, the wall on each side behaves independently.

Following conditions merit consideration of slip joints:

- Where abrupt differential settlement of more than 1% (or 0.01) is expected.
- Where there is an abrupt change in wall height of 5-ft or more.
- Where the wall is underlain by a relatively rigid feature such as an abutment footing or rock outcrop.
- Where a light weight rigid structure such as a box culvert intersects the face of a MSE wall.
- Where the wall terminates into a cast-in-place structure (see Section 5.5 for additional information)
- Where tight horizontal curves occur.

Figure 5-26 shows common slip joint details for segmental precast concrete facing units. As shown in the figure, the slip joint design uses either an exposed slip joint panel having its own soil reinforcement element or a hidden “backup” panel in the backfill behind the facing panel. In either case the normal connection between two panels is broken and independent movement on each side of the slip joint is possible. Figure 5-27 shows a slip joint detail for modular block facing walls.

5.4.6 Wall Curves

Curves in walls are approximated by chords that are equal to the nominal width of the facing units. Therefore, smaller wall facing units such as the modular block units are able to navigate sharp curves better than larger precast concrete facing units. Similarly, 5-ft (1.5 m) wide precast concrete facing units can navigate sharper curves than 10 ft (3 m) wide facing units. For precast concrete facing units, curves with radius as small as 50 ft (15 m) can be achieved for 5 ft (1.5 m) wide facing units with a $\frac{3}{4}$ -in. (19 mm) joint opening. For curved walls, regardless of the type of wall facing, it is critical to provide details for wall layout. The relationship of wall alignment to roadway alignment should be clearly provided. Clear dimensions need to be provided on project drawings for offsets from reference alignments and whether these offsets are relative to top of wall or bottom of wall, especially in the event of stepped foundations.

Figure 5-28 shows a typical detail for layout of geogrid reinforcement for walls with modular block facing units. Geogrid reinforcements typically require 100% area coverage whereas steel reinforcements are generally discrete and can be placed perpendicular to the wall face curves. In the case of geosynthetic reinforcements excessive overlap can result in reduced pullout resistance since contact between geosynthetics is smoother than contact between soil and geosynthetic. Therefore, a minimum soil layer of 3 in. (75 mm) between geosynthetics in the overlap zone is recommended as shown in Figure 5-28.

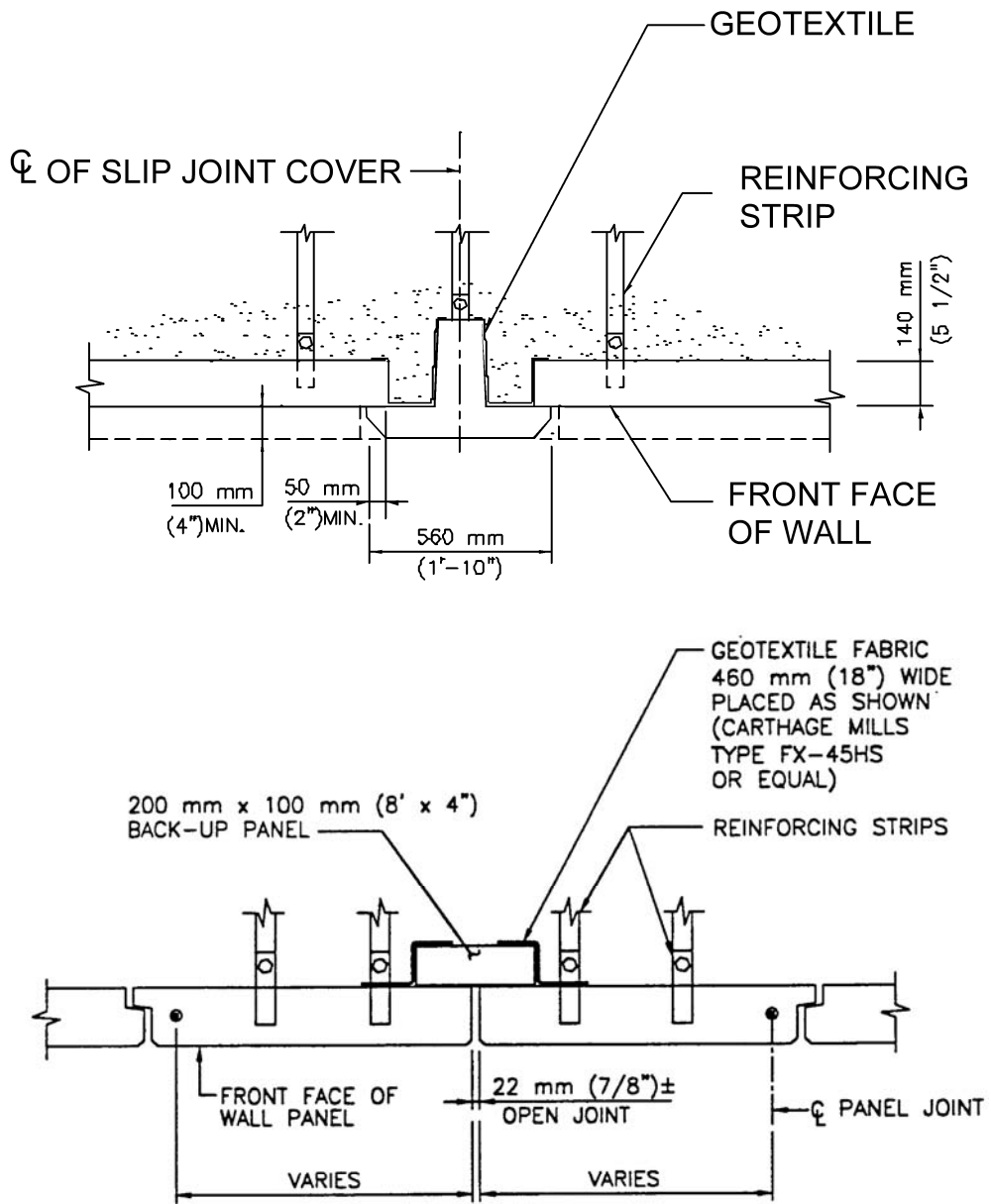

Figure 5-26. Example slip joints for segmental precast panel facings.

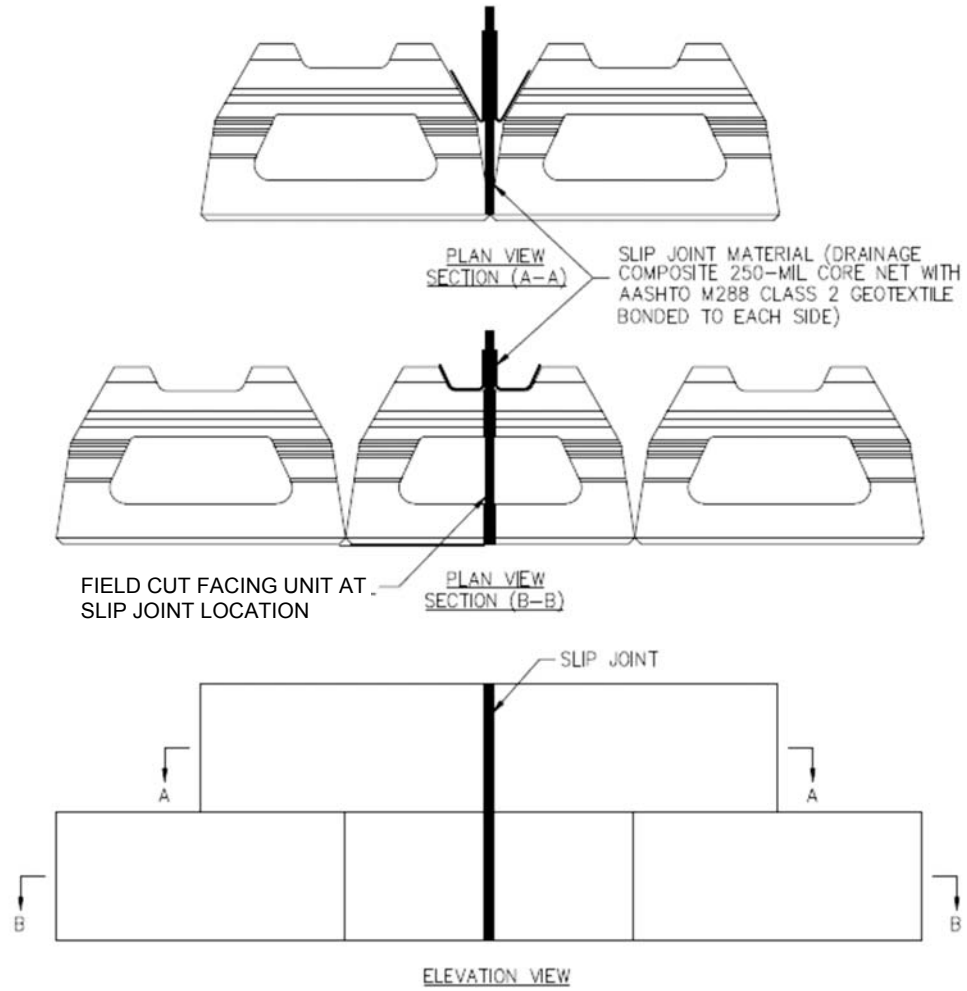

Figure 5-27. Example slip joint for modular block wall facings.

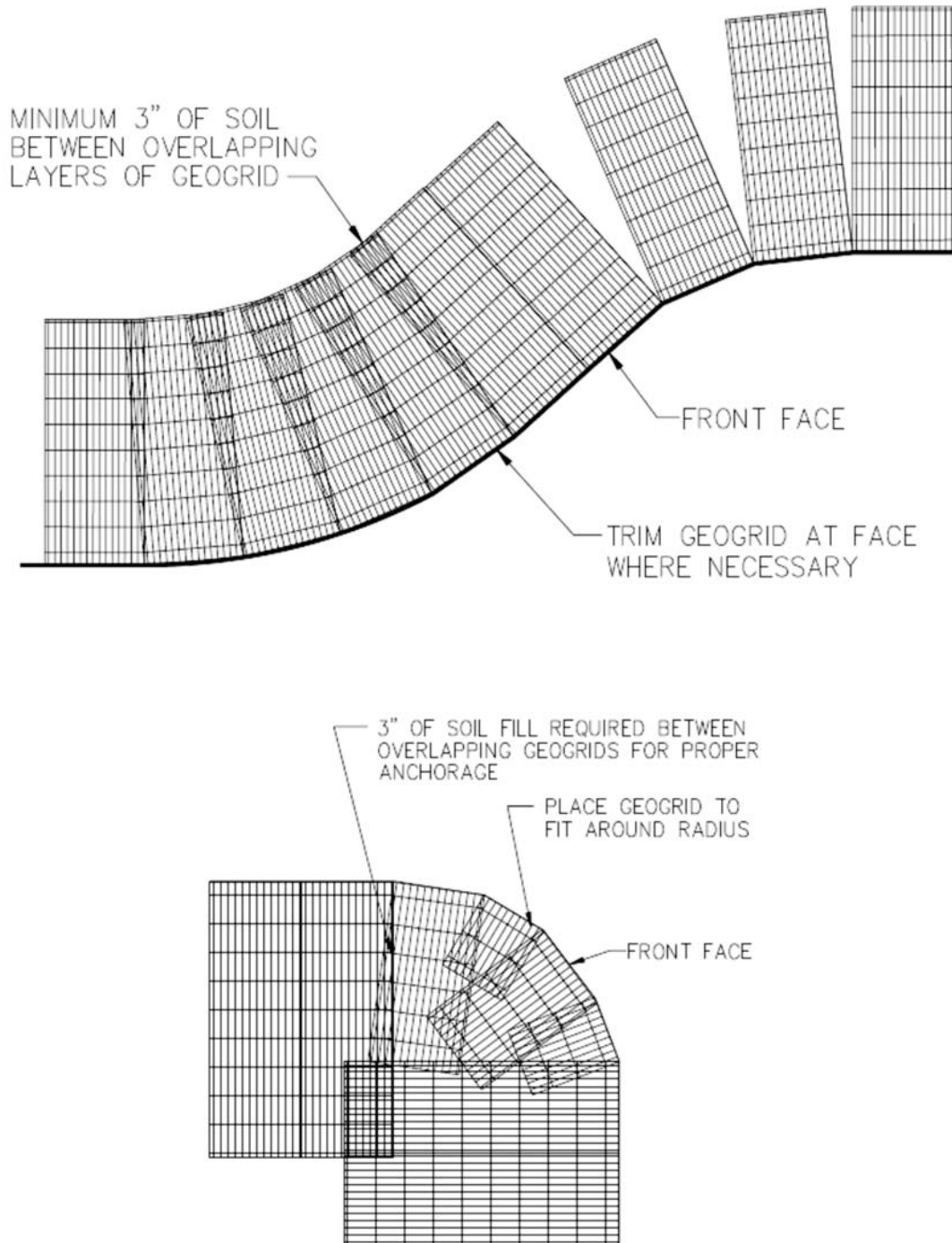

Figure 5-28. Example layout of geogrid reinforcement for walls with curves.

5.4.7 Wall Corners

When two MSE wall segments intersect to form an “external” (e.g., 90 degree) or an “internal” (e.g., 270 degree) corner, both wall segments will tend to move laterally such that corners tend to open up. Corner elements should be provided as shown in Figures 5-26a and 5-26b to accommodate differential movements, prevent fill from moving through the crack, and provide aesthetic treatment.

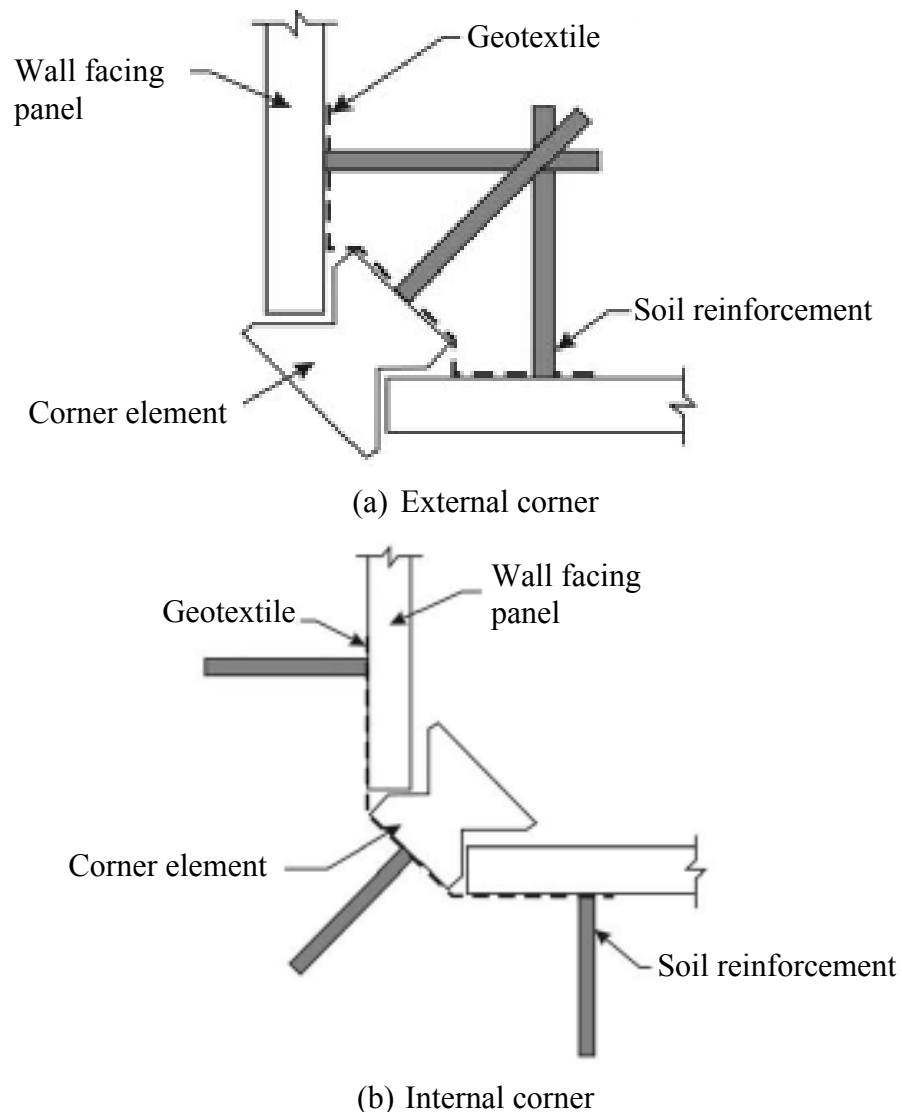

Figure 5-29. Example corner details.

Acute Angle Corners

External wall corners with an angle of less than 70 degrees, i.e., acute angle, should be avoided because of construction difficulties, e.g., compaction in corners and placement of reinforcements. However, if such a situation cannot be avoided, then the wall corner should be based on following considerations:

- The acute angle corner should be designed as a bin wall for the extent of the wall where the full length of the reinforcement cannot be installed without encountering the opposite wall face. In the bin wall section, the reinforcing elements are either structurally connected to both wall faces forming the acute angle corner or overlapped if there is adequate space to develop the required pullout resistance.
- Full-height vertical slip joints should be provided at the interface of acute corner and after the last column of panels where full length reinforcements can be placed.
- The soil reinforcement attached to the slip joints should be oriented perpendicular to the slip joint panels and shall be the full design length.
- Light weight concrete should be considered as an alternate to placing and compacting fill.
- Deformation compatibility between the bin wall section and the rest of the MSE structure should be carefully evaluated.

5.4.7 Two-Stage Facing

MSE walls with 2-stage facing systems can be used where significant (e.g., $> 1/100$) differential settlements are anticipated and use of slip joints, larger joint openings and/or ground improvement are not feasible to minimize the adverse effects of differential settlements. In an MSE wall with 2-stage facing, the primary MSE wall is constructed with a flexible face such as wire face or geosynthetic. After the primary flexible face wall has been constructed, it is left in place for a pre-determined amount of time to induce the settlements. Once the settlements are within acceptable limits, the facing units are installed in the second (final) stage. Figure 5-30 shows conceptual details of a 2-stage system that has been implemented in the industry; other similar details can be developed. Following are some general considerations for a 2-stage MSE wall system:

- The 2nd facing while usually consists of concrete panels should have a leveling/foundation pad with alignment/restraining mechanisms such as pins or dowels to receive and align the facing units as well as provide bearing resistance.
- In addition to the usual connections between facing units, e.g., tongue-and-groove joints, additional connection elements such as dowels may be needed based on the facing unit type.
- Turn-buckle type of connectors are used between the 1st stage wire mesh facing and the 2nd stage concrete facing units. The size and type of the turn-buckles and the number of connectors is a function of the facing panel size, distance between the two facing units, the type of infill used as well as the amount of relative settlement anticipated between the two facing systems after the 2nd stage facing is constructed. Detailed structural analysis and design of the connections should be performed.
- The sequence of construction should be clearly noted on the plans.

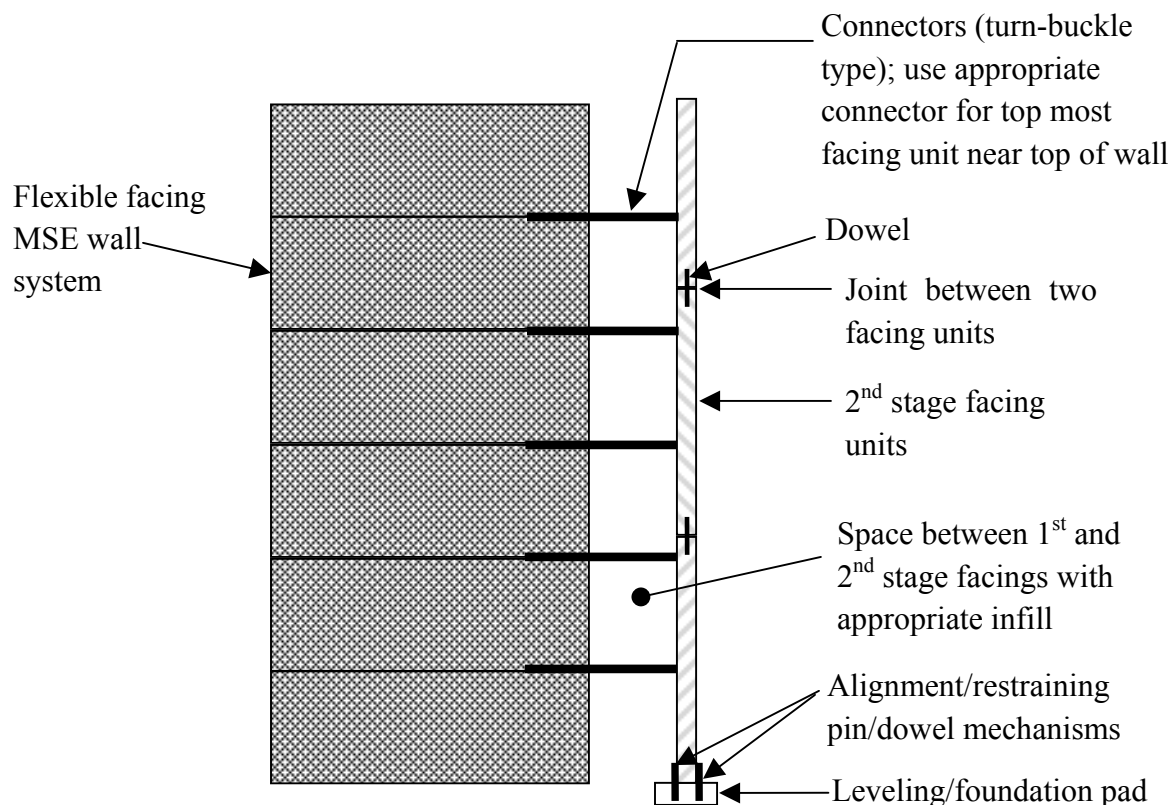

Figure 5-30. Conceptual connection details for a 2-stage facing system.

5.5 WALL INITIATIONS AND TERMINATIONS

The initiation and/or termination of an MSE wall may abut into another structure feature, slope or existing ground. The junctures of MSE walls with other structures are critical locations that are often observed to have distress such as misaligned facing units, leakage of backfill and erosion. Therefore, proper detailing is required at these locations. Following are some recommendations for wall initiations and terminations:

- The juncture of MSE walls and cast-in-place structures must be designed to prevent loss of fines and must allow for differential settlement between the two types of construction. Typical configurations for segmental precast panel facing units are shown in Figure 5-31. Either bituminous joint filler as shown in Figure 5-5a or a backer rod system and sealant as shown in Figure 5-31 is used. A common detail for a MBW facing unit is shown in Figure 5-32.
- A cast-in-place structure may have a lip to mask the joint as shown in Figure 5-31c. Sufficient distance between the facing and lip should be provided to allow for outward movement of the wall during construction. A geotextile should be used behind the joint to contain the soil. Joint filler such as expanded polystyrene may be used between the edge of the facing panel and the cast-in-place structure.
- Abrupt changes in wall heights should be avoided near wall initiation and termination points. This results in differential settlements and undesirable rotation of the facing units due to reduced confining pressures at such locations. Consideration may be given to not stepping the leveling pad within 10 ft (3 m) of the start or end of the wall.
- When starting or terminating into slopes and existing ground, the wall should be protected against erosion by vegetation and adequate embedment. In cases where the wall is adjacent to a steep slope or stream, riprap underlain by a filtration aggregate or geotextile may be needed. Swales should be used to divert water away from the end of the wall as discussed in section 5.3.3.

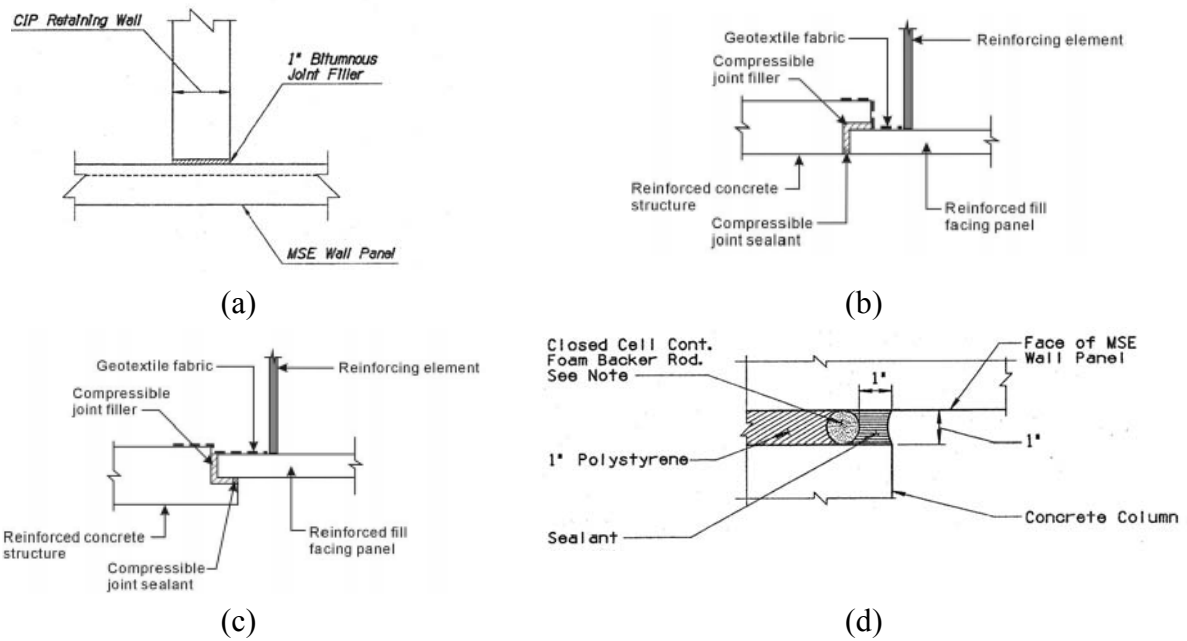

Figure 5-31. Common joint details between segmental precast panel facing units and CIP structures.

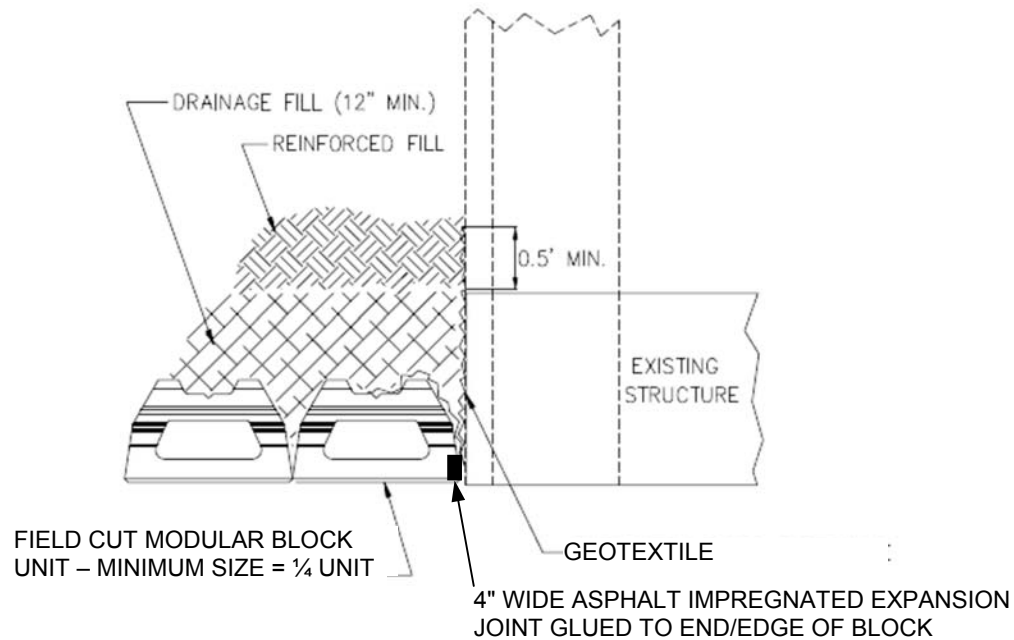

Figure 5-32. Common joint between modular block facing units and CIP structures.

5.6 AESTHETICS

One of the attractive features of MSE walls is that aesthetics can be readily incorporated into the precast facing units. Several examples of wall aesthetics are shown in Figure 5-33. The choice of aesthetic treatments is virtually unlimited, however, it must be recognized that any aesthetic treatment should be compatible with the precasting processes and the construction tolerances. Following are some general guidelines that should be considered while developing aesthetic treatments:

- Cost of treatments that require special form-liners must be considered in the project cost estimate because form-liners require special fabrication and their number of uses is limited.
- Generally, the relief of the protruding artwork should be less than 1.5 in. (38 mm).
- Do not hang heavy aesthetic treatments from the facing units unless the facing units and the internal soil reinforcements are designed to withstand the forces from the artwork and environmental forces due to wind, snow, etc.
- Consider facing construction tolerances in formliner fabrication processes.
- Consider compatibility of the wall construction tolerances with the tolerances in details of the adjacent aesthetic treatments. Relief patterns are difficult to maintain between a cast-in-place structure and an adjacent MSE walls as illustrated in Figure 5-33(a), and is not recommended. Relief patterns between structures should be interrupted by a false column or other feature, as illustrated in Figure 5-33(b).
- Horizontal patterns parallel to the horizontal panel joints may not align after construction due to differential settlement.
- Consider using irregular patterns such as Ashlar stone that tend to hide inevitable imperfections in lines across joints between facing units.
- Consider the angle of sunlight expected at the location of the wall. At various times of the day, sunlight tends to accentuate the effect of the aesthetic features. The effect of imperfections resulting from regular construction tolerances on the artwork may be exaggerated leading to a false sense of problems and/or poor artwork.

- Consider use of colors that are compatible with the wall facing material and weathering of the color scheme.
- Aesthetic treatments may use obstructions, acute corners, and face penetrations for effect, which require careful design review along with increased inspection.



(a)

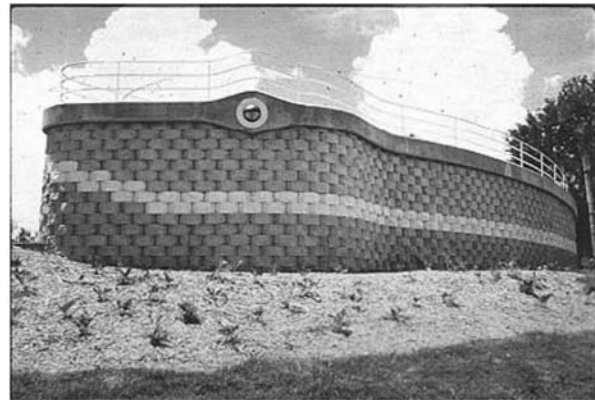

(b)



(c)



(d)

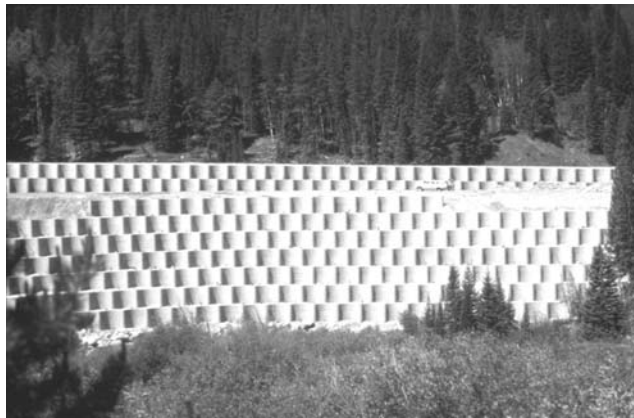

(e)



(f)

Figure 5-33. Example of MSE wall aesthetics.

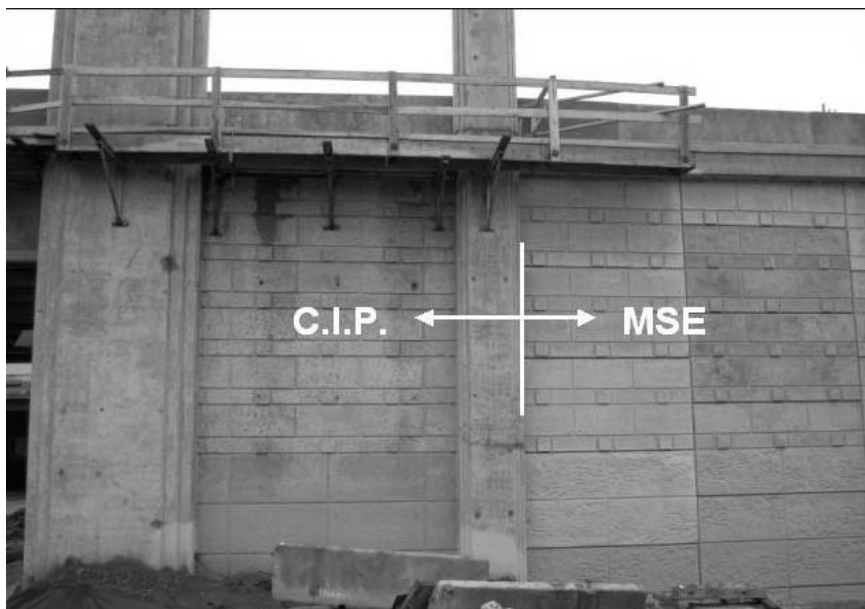

Figure 5-34. Examples of cast-in-place abutment to MSE wall panel transitions, (a) no transition between C.I.P. and precast panels and difficult to match lines, (b) a false column between C.I.P. and precast panels masks lines that may not match.

CHAPTER 6

DESIGN OF MSE WALLS WITH COMPLEX GEOMETRICS

The basic design methods outlined in Chapter 4 consider MSE structures with simple geometries with reinforcement layers of the same length supporting either a horizontal backfill or a surcharge slope. Although most MSE structures fall into this category, structures with more complex geometries or significant external loads are feasible and require consideration during the selection process. They include:

- Bridge abutments with MSE walls
- Superimposed (tiered) MSE walls
- MSE Walls with uneven length reinforcements (trapezoidal walls)
- Back-to-back MSE (BBMSE) walls
- Shored MSE (SMSE) walls for steep terrains and low volume roads
- Stable feature MSE (SFMSE) walls

Schematics of these complex cases are illustrated in Figure 6-1.

The shape and location of the maximum tensile forces line are generally altered by both the geometry and the loads applied on the complex MSE wall structure. It is possible to assume an approximate maximum tensile force line for each. However, supporting experience and analysis are more limited than for rectangular reinforced soil walls.

For complex or compound structures, it is always difficult to separate internal stability from external stability because the most critical slip-failure surface may pass through both reinforced and unreinforced sections of the structure. For this reason, both global and compound stability analyses are required for these types of complex structures. The current method for performing these analyses is to use an ASD reinforced soil slope stability computer method, as detailed in Chapter 9. An alternative method is to adapt the simple modification to the global and compound stability analyses for the LRFD procedure as discussed in Chapter 4.

The following sections give guidelines for each complex case identified in Figure 6-1.

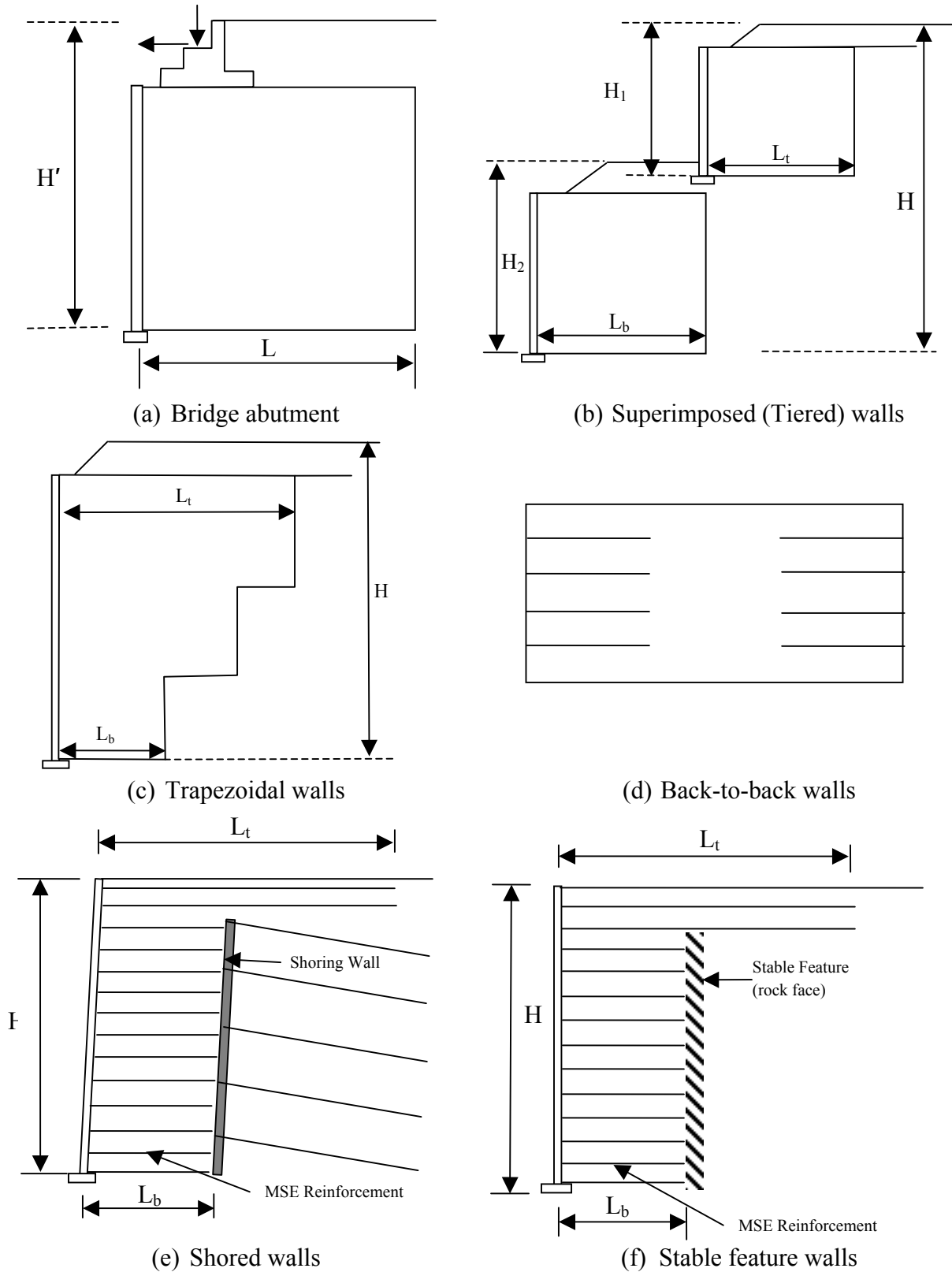

Figure 6-1. Types of complex MSE structures.

6.1 BRIDGE ABUTMENTS WITH MSE WALLS

Bridge abutments have been designed to support the bridge superstructure on a spread foundation constructed directly on the reinforced soil zone, or on a deep foundations constructed through the reinforced soil zone.

The configuration wherein bridge superstructure is supported on a spread footing on top of the reinforced soil zone may be more economical compared to abutments supported by deep foundation through the reinforced soil zone, and should be considered when the projected settlement of the foundation and reinforced volume is rapid/small or essentially complete, prior to the erection of the bridge beams. Based on field studies of actual structures, AASHTO (2007) suggests, that tolerable angular distortions (i.e., limiting differential settlements) between abutments or between piers and abutments be limited to the following angular distortions (in radians):

- 0.008 for simple spans, and
- 0.004 for continuous spans

This criteria, suggests that for a 100 ft (30 m) span for instance, differential settlements of 4.8 in. (120 mm) for a continuous span or 9.6 in. (240 mm) for a simple span, would be acceptable, with no ensuing overstress and damage to superstructure elements. On an individual project basis differential settlements of smaller amounts may be required from functional or performance criteria. Settlements well within the tolerable range can often be achieved with MSEW abutments on spread footings.

6.1.1 MSEW Abutments on Spread Footings

Where fully supporting the bridge loads, MSEW bridge abutments are designed by considering them as rectangular walls with surcharge loads at the top. The base width of the bridge support spread footing, b_f , and the location of the toe of the footing with respect to the back face of the walls panels, c_f , is commonly such that $b_f + c_f$ is greater than $H/3$. In this case, the shape of the maximum tensile force line, i.e., the critical failure surface, has to be modified to extend to the back edge of the spread footing. The variation of K_r/K_a and F^* also need to be modified. Figure 6-2 shows definitions of various parameters including measurements of heights and depths.

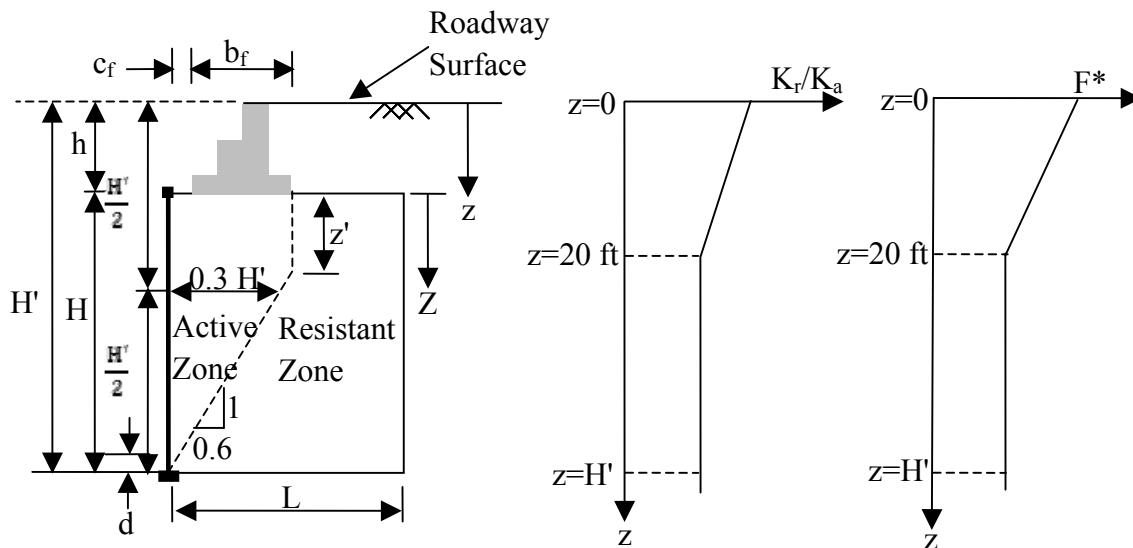

Notes:

- d is the depth of embedment
- Z is measured below bottom of footing; z is measured from top of spread footing
- H is measured from top of leveling pad to bottom of bridge support spread footing
- h is height of the wall as measured from bottom of bridge support spread footing to finished roadway surface
- H' is height of wall as measured from top of leveling pad to finished roadway surface
- $z = Z + h$; $z' = H - (c_f + b_f)/0.6$
- Within height z' the length of the reinforcement in the active zone is $L_a = c_f + b_f$

Figure 6-2. Geometry definition, location of critical failure surface and variation of K_r and F^* parameters for analysis of a MSEW abutment on spread footing.

Although MSEW abutments on spread footings have historically almost always used inextensible, steel reinforcements, they can also be used with extensible reinforcements. However, similar shifts in the maximum tension line to the back of the footing have been observed for extensible reinforcement. Therefore, the maximum tensile force line should also be modified for extensible reinforcement if the back edge of the footing extends beyond a distance of $H^* \tan(45^\circ - \phi^\circ/2)$ from the wall face. These maximum tensile force lines should be compared with the critical failure surface from compound stability analysis and the more conservative profile of the failure surface should be selected.

Successful experience with construction of MSEW abutments on spread footings has suggested that the following additional details be implemented:

- Require a minimum offset from the front of the facing to the centerline of the bridge bearing of 3.5 ft (1 m).
- Require a minimum clear distance, c_f , of 6 in. (150 mm) between the back face of the facing panels and the front edge of the footing.
- In areas that are susceptible for frost, the frost effect can develop from both the top of the wall as well as the front of the wall. Where significant frost penetration is anticipated, place the abutment footing on a bed of non-frost susceptible compacted coarse aggregate (e.g., No. 57 as specified in AASHTO M 43). The thickness of the aggregate bed should be minimum 3 ft (1 m) or 1 ft (0.3 m) below deepest anticipated frost penetration depth, whichever is greater. Separation geotextile should be provided at the interface of No. 57 coarse aggregate and the surrounding fills (reinforced, retained and above the footing base). Adjoining sections of the separation geotextile should be overlapped by a minimum of 1 ft (0.3 m).
- For the analysis of the spread footing on top of the reinforced soil zone, use the following values of bearing resistance of the reinforced soil zone
 - For service limit state, bearing resistance = 4 ksf (200 kPa) to limit the vertical movement to less than approximately 0.5 in. (12.5 mm)
 - For strength limit state, factored bearing resistance = 7 ksf (335 kPa)
(Note: AASHTO does not provide a value of factored bearing resistance at strength limit state and the recommended value is based on the authors' experience.)
- Use the maximum horizontal force at top reinforcement level below the abutment for the design of connections of the panels at all reinforcement levels.
- Extend the density, length and cross-section of reinforcements of the abutments to wingwalls, for a horizontal distance which is greater of the following:
 - 50 percent of the maximum height, H , of the abutment wall face.
 - $c_f + b_f + 3$ ft (1 m) where c_f and b_f are as shown in Figure 6-2
- There will be 2-way soil reinforcement within the length of reinforcement perpendicular to the abutment face. It is preferable that reinforcement is not placed on top of each other in the zone of 2-way reinforcement. The overlapping reinforcement should be separated by 3 to 6 in. (75 to 150 mm) of soil or some multiple of compacted fill height. This may be achieved by appropriately adjusting the steps of the leveling pad between the abutment face wall and the wing walls. This practice is especially recommended where a corrosion monitoring program is implemented in the abutment area (Elias et al., 2009).

- To prevent adverse stress concentrations at the reinforcement connections, the minimum vertical clearance between the bottom of the bridge support spread footing and the top level of reinforcement should be 1 ft (0.3 m).
- Due to the relatively high bearing pressures near the panel connections, the adequacy and nominal capacity of panel connections should be determined by conducting pullout and flexural tests on full-sized panels.
- The seismic design forces should also include seismic forces transferred from the bridge through bearing supports which do not slide freely (e.g., elastomeric bearings).

In the LRFD context, the design of a MSEW abutment on spread footing requires careful separation of various load types. This results in a complex set of inter-related equations which are best illustrated by a worked example. Example E4 presents a comprehensive step-by-step illustration of both external and internal stability of a MSEW abutment on spread footing. The reader should become familiar with Example E5 because the principles and computations used in the example problem can also be applied to different complex geometries.

6.1.2 MSEW Abutments on Stub Footings Supported by Deep Foundations through Reinforced Wall Fill

For cases where MSEW abutments on spread footings may not be viable based on considerations of unacceptable post-construction settlements or other reasons, the bridge superstructure is placed on stub footings supported by deep foundations such as driven piles or drilled shafts. In this configuration, vertical loads are not considered in analysis since they are transmitted to an appropriate bearing stratum by deep foundations. However, the horizontal bridge and abutment backwall forces must be resisted by methods dependent on the type of abutment support, namely:

- **For conventional abutments**, the horizontal forces must be resisted by extending soil reinforcement from the back edge of the abutment footing (cap). The resistance is provided by the interaction between the soil and reinforcement over the full length of the reinforcement. A typical detail is shown in Figure 6-3. Alternatively, the horizontal forces may be resisted by the lateral resistance of the deep foundation or by other means.

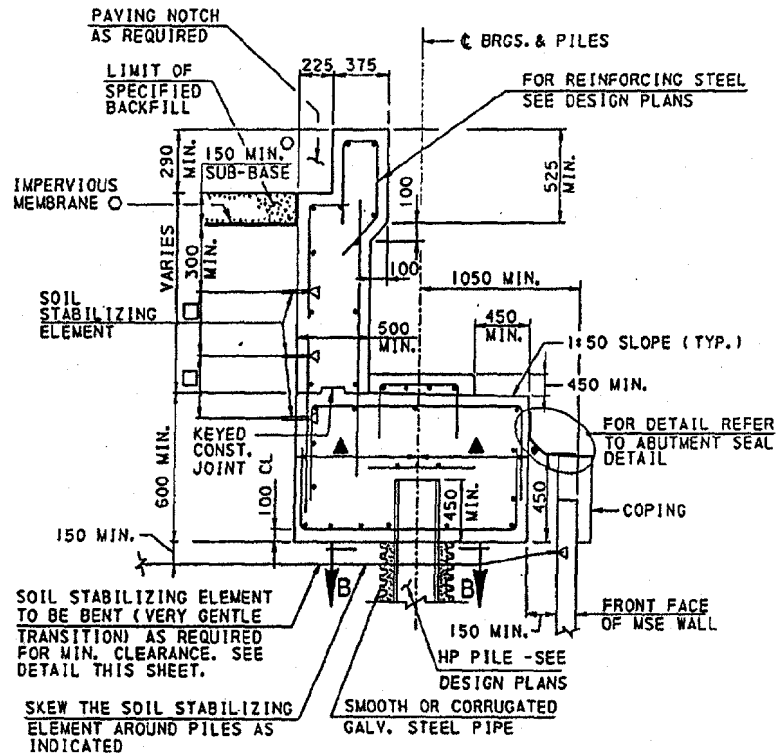
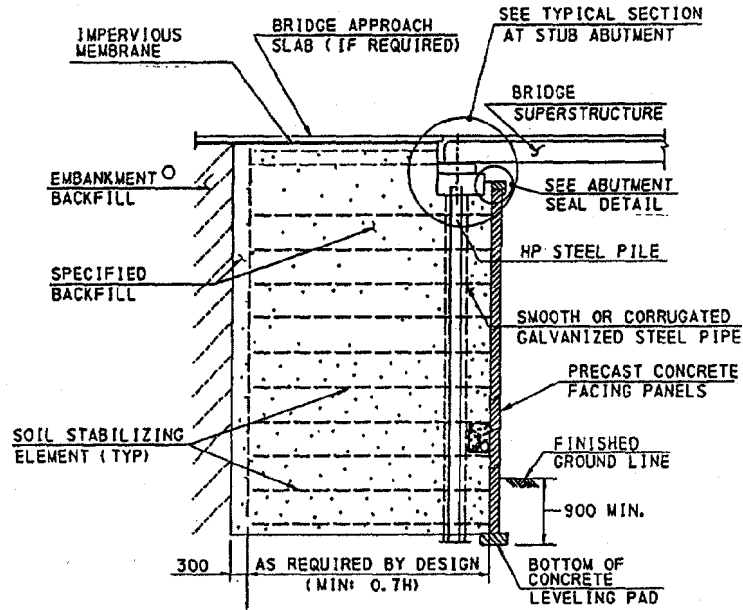

Note: All dimensions are in mm [1 in. = 25.4 mm]

Figure 6-3. Details of a typical pile supported MSE abutment.

- **For integral abutments**, the horizontal forces and its distribution with depth may be developed using a lateral load (p)-lateral deflection (y), i.e., p-y methods. These horizontal forces are added as a supplementary force to be resisted by the reinforcements. These forces will vary depending on the following:
 - magnitude of the horizontal loads and moments,
 - diameter and spacing of deep foundations, and
 - clear distance between the back face of wall panels and front of the deep foundation elements.

Several agencies have constructed integral abutments in front of MSE walls as discussed in Section 6.1.3 in order to avoid applying a lateral stress to soil behind the abutment.

Figure 6-4 shows a typical supplemental lateral pressure that must be considered in the internal stability analysis. This lateral pressure is addressed in a fashion similar to the inverted triangular lateral pressure distribution shown in Figure E5-2 of Example Problem E5. The effect of the roadway fill and the live load surcharge above the MSE wall is also addressed in a fashion similar to that for the same features in Example E5. The balance of the computations remains identical to those in Chapter 4.

Based on successful experience of the authors with abutment construction of MSE walls with deep foundations through the reinforced fill, following are suggested additional details, as applicable:

- Where significant settlement of the embankment is anticipated, provide casings (e.g., sonotubes or corrugated metal pipes) in the reinforced soil zone to permit construction of deep foundations after the MSE wall is constructed and settlement has occurred. In the case of driven piles it may be possible to isolate the piles from the casings by filling the annulus with loose sand just prior to construction of the footing at top of the piles. In the case of drilled shafts it may not be possible to isolate the shaft from the casing in an economical manner unless another internal casing is used.
- In the case where deep foundations are constructed prior to MSE wall construction, and negative skin friction, i.e., downdrag force, is anticipated, provide a casing around the deep foundation element, through the reinforced fill. The casing is filled with sand just prior to the construction of the footing at top of the deep foundation element. Alternatively, a bond breaker can be used on the deep foundation element when negative skin friction, i.e., downdrag force, is anticipated.

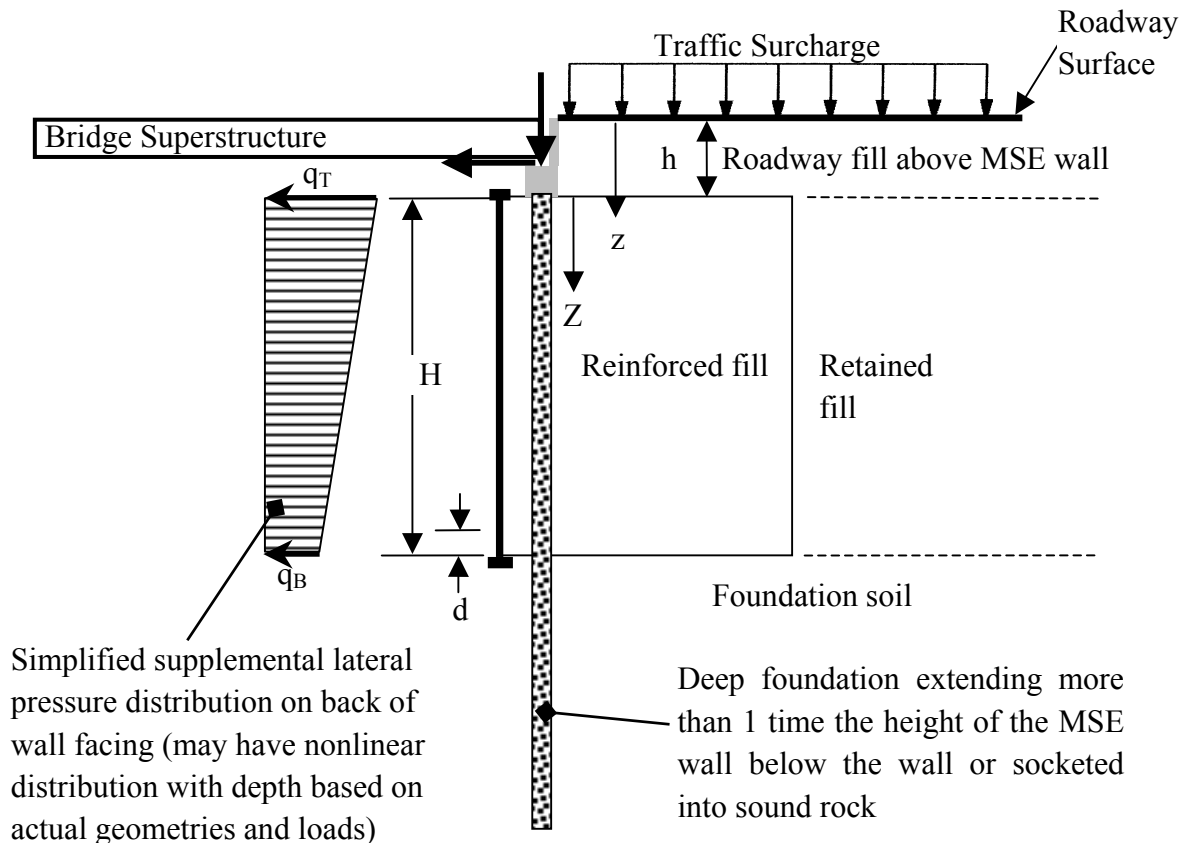

Notes:

- d is the depth of embedment
- H is measured from top of leveling pad to top of coping
- z is measured below finished grade behind footing
- The K_r/K_a and F^* values are assumed to start at $z = 0$, i.e., below the finished grade behind the footing.

Figure 6-4. Geometry definition and typical supplemental lateral pressure distribution from deep foundation on MSE wall face.

- In the case where deep foundations are constructed prior to MSE wall construction and/or the deep foundation element is not isolated from the casing as noted above, the horizontal stresses as shown in Figure 6-4 must be included in the analysis of MSE wall. If the deep foundations are constructed through casings and isolated from the casings, the horizontal stresses may be neglected in the design of the MSE wall. However, it must be realized that this configuration leads to a longer unsupported length of the deep foundation that may result in undesirable movements at the bridge seat level in addition to increased size of the deep foundation element.

- For driven piles extending through the reinforced soil zone, require a minimum offset from the back face of the wall panels and the front of the driven pile elements as 1.5 ft (0.5 m).
- For drilled shaft extending through the reinforced soil zone, require a minimum offset from the back face of the wall panels and the front of drilled shaft elements as 3 ft (1 m). This criterion provides the necessary clear space to achieve proper compaction of the soil in this area. Thus, for example, if drilled shafts with a maximum dimension of 2 ft (0.61 m) are used then the minimum clearance is 3 ft (1 m). For walls where reinforcements will be splayed (e.g., steel strip reinforcements), require a minimum offset from the back face of the wall panels and the front of deep foundation elements as the greater of 3 ft (1 m) or 1 times the diameter of the deep foundation. Thus, for example, if a drilled shaft of 4 ft (1.2 m) diameter is used then the minimum clearance is 4 ft (1.2 m). These criteria provides the necessary clear space to achieve proper compaction of the soil in this area and adequate distance for splaying of reinforcements within the acceptable limits noted in Chapter 5.
- Provide soil reinforcements in the soil behind the abutment footing (cap) as shown in Figure 6-3.

Interference between Soil Reinforcements and Deep Foundations

Design of MSE walls with deep foundations needs careful consideration of the interference between the soil reinforcements and the deep foundation element(s). Where deep foundation elements interfere with the reinforcements, specific methods for field installation must be developed and presented on the plans. **Simple cutting and then bending of the reinforcements during construction should not be allowed.** Guidance for navigating soil reinforcement around vertical obstructions is presented in Chapter 5. Soil cover as recommended in Section 5.4.1 of Chapter 5 between dissimilar metals should be implemented as appropriate.

6.1.3 Alternative Configuration of MSE Walls at Bridge Abutments

An alternative to construction of MSEW abutments that use deep foundations through reinforced backfill is to construct the MSE walls behind abutment foundations that are constructed. In this configuration, the foundations are not constructed within or on top of reinforced fills. Rather the MSE walls supports only the approach fills while the abutments are constructed in configuration of piers. Special details (e.g., bridge approach slabs) are required for this configuration to integrate the MSE walls with the bridge abutment. The major advantage of this type of abutment configuration is that the construction of the foundations for the abutments can be performed independently of the MSE wall construction and that better construction control can be exercised for MSE walls since there are no obstructions through the reinforced backfill.

Based on successful experience of the authors with construction of an abutment configuration with MSE wall behind the abutment foundations, following are suggested additional details, as applicable:

- Require that the bridge superstructure be placed after the construction of the MSE walls so that most of the possible foundation deformations have occurred.
- Construct the foundations prior to construction of the MSE wall, but construct the abutment columns after the construction of the MSE wall. In this construction sequence, the foundation deformation due to the construction of the adjacent MSE wall can be compensated for by adjusting the connection of the abutment structure rather than running the risk of abutment structure deforming to the extent that it does not fit with the bridge superstructure at the beam seat level.
- Consider construction of a false wall in front of the abutment substructure, i.e., the element between the foundation and the superstructure. This false panel serves to protect the abutment elements against vehicular impact as well as protecting vehicle occupants. The false wall may be structurally connected to the abutment substructure or an independent wall with a separation of 3 to 6 in. (75 mm to 150 mm) with the decision based on the design of the abutment substructure and its ability to absorb vehicular impacts.
- For integral abutments with a wall supported on deep foundations, a wrapped or wire faced MSE wall can be constructed behind the abutment wall, using the abutment as an offset form with a spacer to maintain the distance between the MSEW and the abutment wall as shown in Figure 6-5.

6.1.4 Protection of MSE Wall at Abutments

At abutment locations, the permeation of water through expansion joints into the MSE wall results in a number of seepage problems as discussed in Chapter 5 including the potential for salt-laden runoff, which could result in a chloride rich, corrosive environment near the face panel connection for a significant percentage of the wall height. To minimize this problem, seepage should be controlled as shown on Figure 6-6.

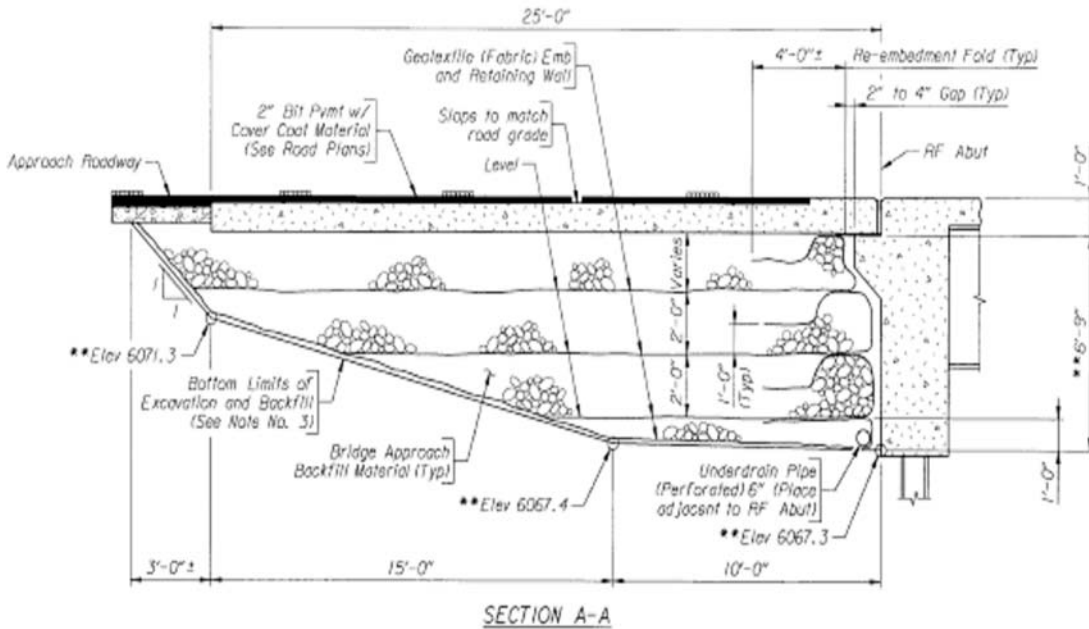
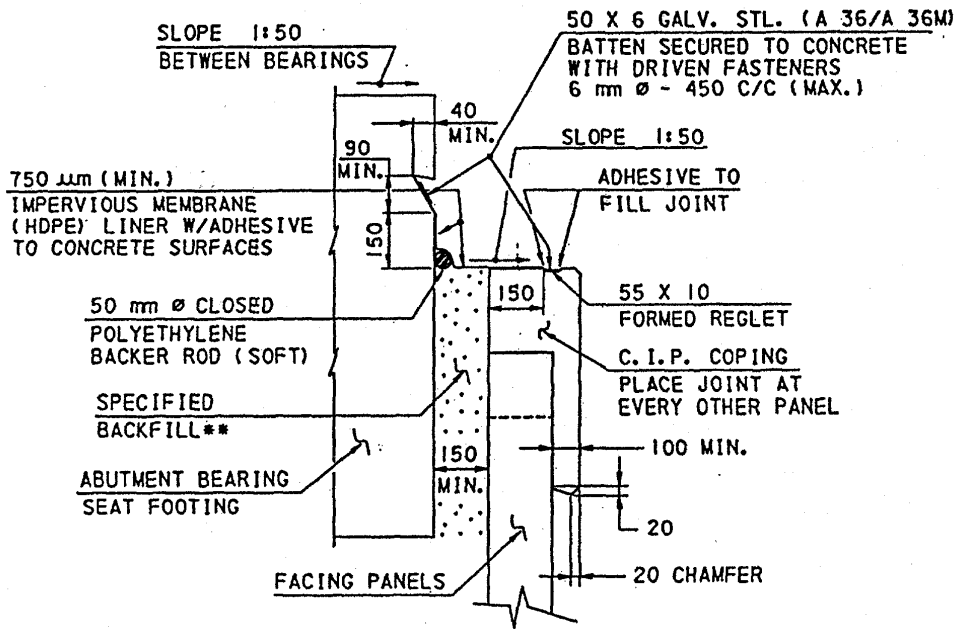

Figure 6-5. Example of use of a geosynthetic wrapped face wall behind an integral abutment.



Note: All dimensions are in mm [1 in. = 25.4 mm]

Figure 6-6. Example abutment seat detail.

6.2 SUPERIMPOSED (TIERED) MSE WALLS

For tall walls consideration should be given to superimposed (tiered) walls from the viewpoint of constructability. Reconfiguring a tall wall in superimposed walls with smaller heights permits a fresh start with a new leveling pad, reduces vertical stress on facing elements, and permits better control of vertical alignment of the wall face. Analytically, depending on the offsets between the superimposed walls, another beneficial effect might be an overall (equivalent) sloped wall face that results in lesser lateral force on the whole wall system.

6.2.1 2-Tier Superimposed Walls

Figure 6-7 shows a configuration of a 2-tier superimposed MSE wall system. The design of superimposed MSE walls requires two analyses as follows:

- (1) A design using simplified design rules for calculating external stability and locating the internal failure plane for internal stability as shown in Figure 6-7.
- (2) A slope stability analysis, including both compound and global stability using a reinforced soil global stability computer program outlined in Chapter 4. This is an essential computation.

The definition of wall heights, H_1 and H_2 , and offset D between walls for a 2-tier superimposed wall configuration is shown in Figure 6-7. Using the definitions in Figure 6-7, for **preliminary design**, the following minimum values for reinforcement length, of L_1 and L_2 , should be used for offsets (D) greater than $[1/20 (H_1 + H_2)]$:

$$\text{Upper wall: } L'_1 \geq 0.7 H_1$$

$$\text{Lower wall: } L'_2 \geq 0.6 H \text{ where } H = H_1 + H_2$$

Based on the definitions in Figure 6-7, following are basic design guidelines:

- Where the offset distance (D) is greater than $H_2 \tan (90-\phi_r)$, walls are not considered superimposed and are independently designed from an internal stability viewpoint,
- For a small upper wall offset; $D \leq [1/20 (H_1 + H_2)]$, it is assumed that the failure surface does not fundamentally change and it is simply adjusted laterally by the offset distance D . The walls should be designed as a single wall with a height H .

In both of the above cases, compound and global stability should be checked.

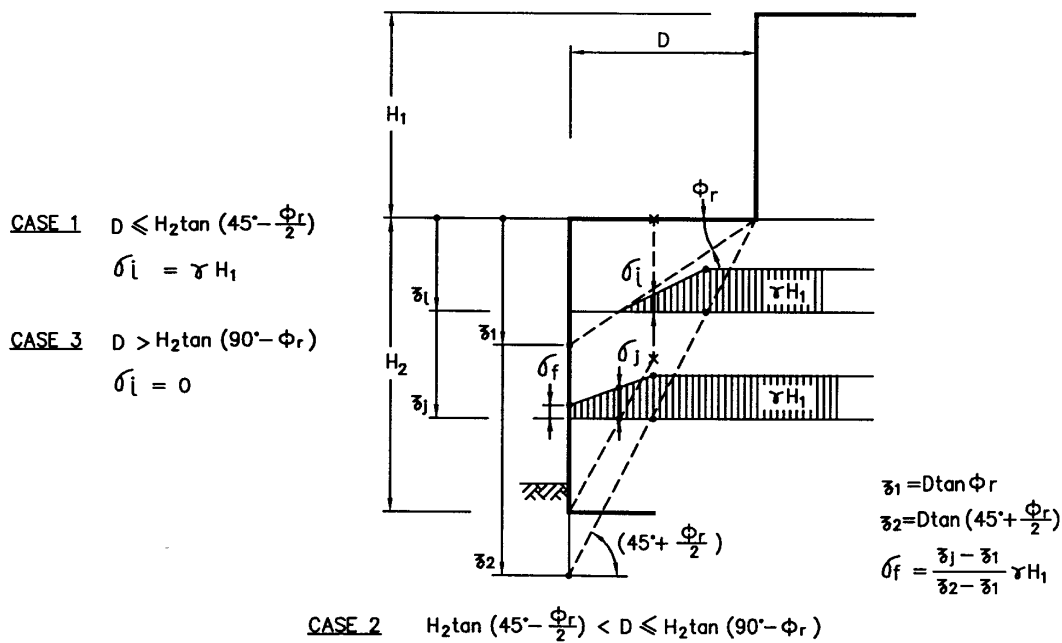
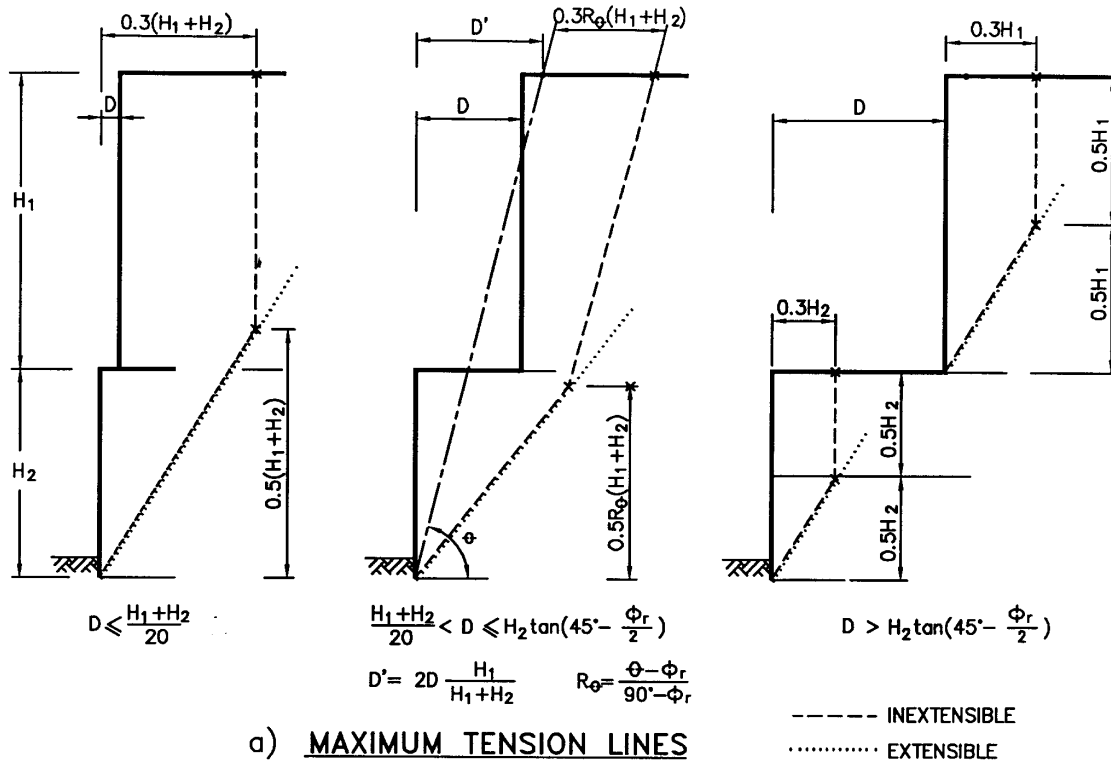

Figure 6-7. Design rules for a 2-tier superimposed MSE wall system.

The stability analysis for a 2-tier superimposed MSE wall system is performed as follows:

- External stability calculations for the upper wall are conventionally performed as outlined in Chapter 4. For the lower wall, consider the upper wall as a surcharge (Load type “ES”) in computing bearing pressures. In lieu of a conventional external sliding stability computation, perform a wedge type slope stability analysis with failure surfaces along and exiting at the base as well as below the base. The overall stability should be investigated at the Service I load combination and a sliding resistance factor of 0.65.
- For calculating the internal stability, the maximum tensile force lines are as indicated in figure 6-7a. These relationships are somewhat empirical and geometrically derived.
- For intermediate offset distances, see Figure 6-7a for the location of the failure surface and consider the vertical pressures in Figure 6-7b for internal stress calculations.
- For large setback distances, $[D \geq H_2 \tan (90-\phi_r)]$, the maximum tensile force lines are considered independently, without regard to the geometry of the two superimposed walls. For internal stability computations, the upper wall is neglected.
- The balance of the computations remains identical as in Chapter 4.

6.2.2 Superimposed walls with more than 2-tiers

The criteria for 2-tier wall presented in Figure 6-7 can be extended to walls with more than two tiers. For such configurations, the global and compound stability analysis becomes even more critical. Methods outlined in Chapter 4 may be used for evaluating the global and compound stability. For internal stability analysis, Wright (2005) and Leschinsky and Han (2004) found that the criteria for additional vertical stress in Figure 6-7b may be used for walls with more than 2-tiers provided that only the immediately overlying tier is considered to contribute to the increase in vertical stress on the lower tier. As an alternative, Wright (2005) presents an elastic solution based on an assumption of “rigid” walls for estimating additional vertical stresses in a given tier of a multi-tier wall due to the effect of all overlying wall tiers. Regardless of the approach used for estimating the increase in vertical stresses for evaluation of internal stability, the analysis of tiered walls should proceed from the top wall to the bottom wall so that the stresses are properly accumulated and accounted for in the design of the bottom-most wall. For preliminary design, the length of the reinforcement of the bottom-most tier can be assumed to be 0.6 times the total height of the wall system.

6.3 MSE WALLS WITH UNEVEN REINFORCEMENT LENGTHS (TRAPEZOIDAL WALLS)

Use of this type of reinforcement geometry should be considered only if the base of the MSE structure is in rock or *competent foundation material*, i.e., foundation materials which will exhibit minimal post construction settlements. Examples of competent foundation materials include materials with SPT N_{60} value greater than 50 and sound rock.

The design of these walls requires two analyses as follows:

1. A design using simplified design rules for determining internal and external stability.
2. A slope stability analysis performed using a reinforced soil stability program checking both global (i.e., circular and wedge type analysis) and compound failure planes.

Simplified design rules for these structures are as follows:

- As shown in Figure 6-8, the wall is represented by a rectangular block (L_o , H) having the same total height and the same cross-sectional area as the stepped section for external stability calculations.
- The maximum tensile force line is the same as in rectangular walls (bilinear or linear according to the extensibility of the reinforcements).
- Minimum base length (L_3) of 0.4H or 8 ft (2.5 m) whichever is greater, with the difference in length in each zones being less than 0.15 H.

For internal stability calculations, the wall is divided in rectangular sections and for each section the appropriate L (L_1 , L_2 , L_3), is used for pullout calculations, using methods developed in Chapter 4.

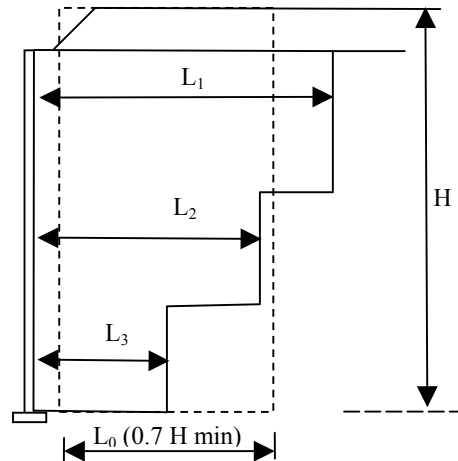

Figure 6-8. Dimensioning of MSE wall with uneven reinforcement lengths.

6.4 BACK-TO-BACK MSE (BBMSE) WALLS

Back-to-back walls are often used for highway ramps. For walls which are built back-to-back as shown in Figure 6-9, a modified value of lateral pressure influences the external stability calculations. As indicated in Figure 6-9, two cases can be considered and are discussed below.

- Case I

For Case I, the overall base width is large enough so that each wall behaves and can be designed independently. In particular, there is no overlapping of the reinforcements. Theoretically, if the distance, D , between the two walls is shorter than $D = H_1 \tan(45^\circ - \phi^\circ/2)$ where H_1 is the taller of the parallel walls, then the active wedges at the back of each wall cannot fully spread out and the active thrust is reduced. However, for design it is assumed that for values of $D > H_1 \tan(45^\circ - \phi^\circ/2) \approx 0.5H_1$ then full active thrust is mobilized.

- Case II

For Case II, there is an overlapping of the reinforcements such that the two walls interact. When the overlap, L_R , is greater than $0.3H_2$, where H_2 is the shorter of the parallel walls, no active earth thrust from the backfill needs to be considered for external stability calculations.

For intermediate geometries between Case I and Case II, the active earth thrust may be linearly interpolated from the full active case to zero.

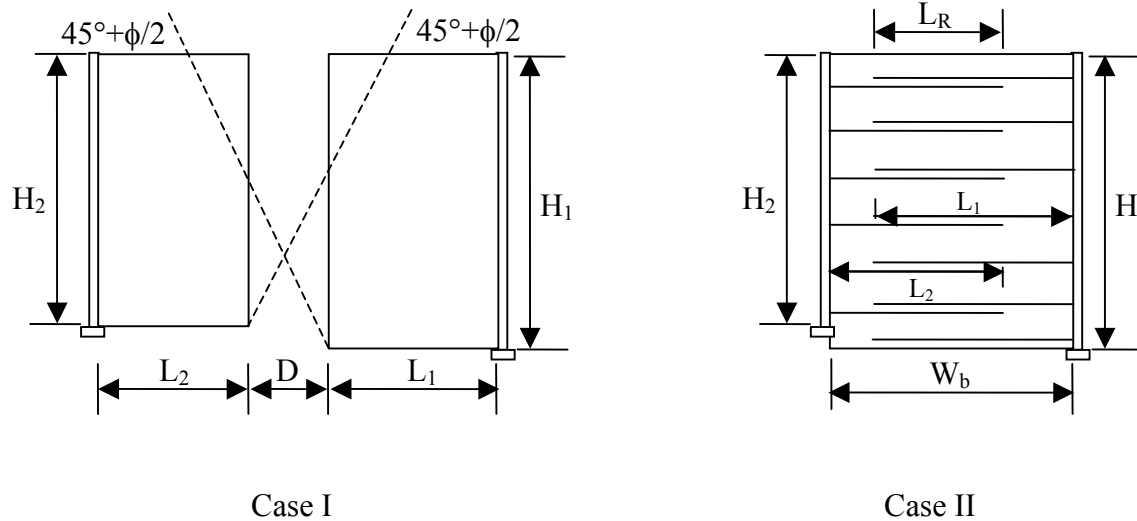

Figure 6-9. Back-to-back MSE walls.

For Case II geometries with overlaps (L_R) greater than $0.3H_2$, the following guidelines should be used:

- $L_1/H_1 \geq 0.6$ where L_1 and H_1 is the length of the reinforcement and height, respectively, of the taller wall.
- $L_2/H_2 \geq 0.6$ where L_2 and H_2 is the length of the reinforcement and height, respectively of the shorter wall.
- $W_b/H_1 \geq 1.1$ where W_b is the base width as shown in Figure 6-9 and H_1 is the height of the taller wall.

The above guidelines are valid for static load conditions or in areas where the seismic horizontal accelerations at the foundation level are less than 0.05g. Back-to-back walls in seismically active areas should be designed based on a more detailed analysis that includes effects of potential non-uniform distribution of seismic and inertial forces within the wall.

For back-to-back walls designers might be tempted to use single layers of reinforcements that are connected to both wall facings. This alternative creates an unyielding structure creating an at rest stress state (K_0) from the top to the bottom of the wall, resulting in much higher reinforcement tensions than previously used in the design method in this manual. The design must include the increases in lateral stress in the determination of the tension in reinforcement and connection and in the design of facing elements. Additionally compaction may induce higher stress at the connection, which must be accounted for in the lateral earth pressure

calculations. Furthermore, difficulties in maintaining wall alignment could be encountered during construction, especially when the walls are not in a tangent section. The exception is the use of geosynthetic wrapped faced walls, where alignment with connections is not an issue. However, while there is a potential for stress relief due to extensible reinforcements, very few instrumented structures have been constructed and therefore even in the case of geosynthetic reinforcements K_o should conservatively be used to calculate the tension in the reinforcements unless numerical modeling is performed to evaluate the anticipated stress state and instrumentation is used to confirm the actual stress conditions.

6.5 SHORED MSE WALLS FOR STEEP TERRAINS AND LOW VOLUME ROADS

In steep terrains MSE wall construction necessitate excavation to establish a flat bench to accommodate the soil reinforcements with a minimum length of greater than 8 ft (2.5 m) or 70% of the height of the wall. Additionally, the required depths of embedment are proportional to the steepness of the slope below the wall toe. In some cases, the excavation required for construction of a MSE wall becomes substantial, and unshored excavation for the MSE wall is not practical, particularly if traffic must be maintained during construction of the MSE wall. Shoring, most often in the form of soil nail walls, has been employed to stabilize the backslope (or back-cut), with a MSE walls being designed and constructed in front of it. Figure 6-10 shows a generic cross-section of this configuration. In this configuration, if the shoring wall is designed as a **permanent** wall it can significantly reduce the long-term lateral pressures on the MSE wall. Such MSE wall configuration is known as a shored MSE or SMSE wall. Details of SMSE walls systems are presented in FHWA-CFL/TD-06-001 (Morrison et al., 2006).

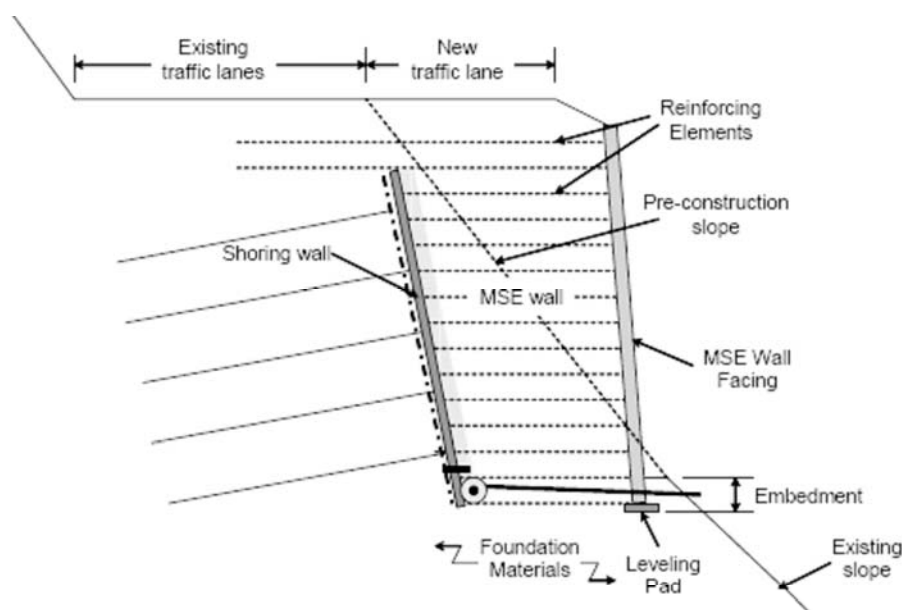
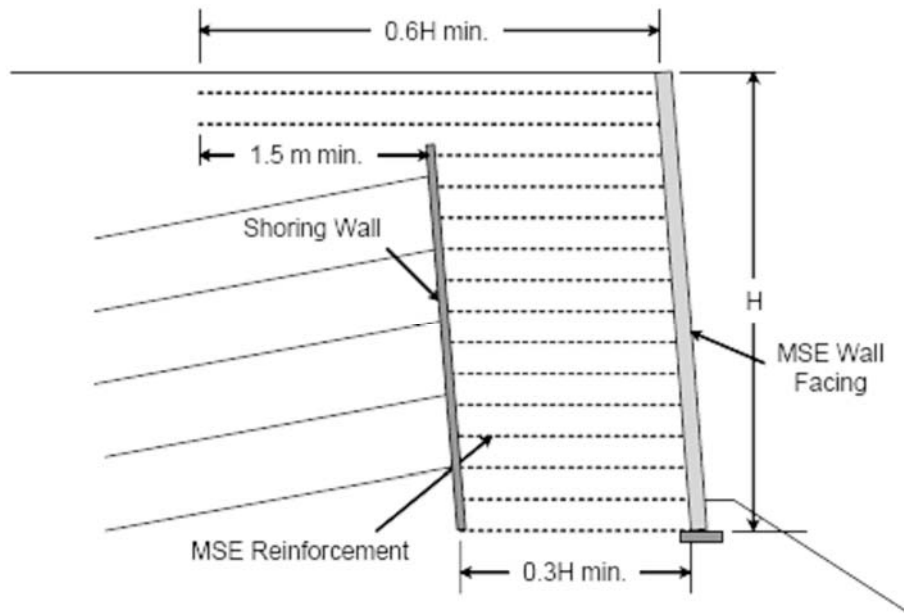

Figure 6-10. Generic cross-section of a shored MSE (SMSE) wall system for steep terrains (Morrison et al., 2006).

For successful implementation of the SMSE walls, the following guidelines should be implemented. These guidelines are valid for static load conditions or in areas where the seismic horizontal accelerations at the foundation level are less than 0.05g. SMSE walls in seismically active areas should be designed based on a more detailed analysis that includes effects of potential non-uniform distribution of seismic and inertial forces within the wall system (both the MSE and the shoring components). Finally, it should be recognized that these walls were developed for low volume roads in mountains and are not recommended in urban areas for roadway widening applications because of the relatively high risk for tension cracks under dynamic effects of traffic at the interface between an existing wall and new MSE wall.

- The shoring wall should be designed as a **permanent** wall whose design life is equal to or greater than that for the MSE wall. For design of shoring systems using ground anchors and soil nail walls, see Sabatini et al. (1999) and Lazarte et al., (2003), respectively.
- Ensure that the drainage features of the MSE wall system and the permanent shoring wall behind it are integrated so that there are no lateral pressures due to hydrostatic conditions in either wall. Note, as discussed in Chapter 5, thin vertical drains behind the face of the soil nail wall do not necessarily fully relieve hydrostatic stress. Thus, some level of hydrostatic stress based on flow net analysis should be included in the design or horizontal drains and should be considered in the design of SMSE walls.
- Figure 6-11 presents the minimum recommended geometry of a SMSE system. The minimum length of the reinforcement is $0.3H$ or 5 ft (1.5 m) whichever is greater. Where adequate construction space is available (or can be made temporarily available with permanent underground easement), it is recommended that the upper two layers of reinforcement are extended to a minimum length of $0.6H$ or a minimum of 5 ft (1.5 m) beyond the shoring wall interface, whichever is greater, as illustrated in Figure 6-11a. This feature limits the potential for tension cracks to develop at the shoring/MSE wall interface, and resists lateral loading effects. Extension of the upper two layers is intended to result in a wall cross-section as depicted in Figure 6-11a, where the height of the shoring wall is at least $2/3$ of the MSE wall height, H . These guidelines should only be applied to wall designs that meet this constraint over the majority of their length. Walls with short shoring walls, i.e., heights less than $2/3H$ over most of their length are outside the scope of these guidelines. It should be noted that near the ends of the retaining wall the height usually tapers, and the shoring wall height may be less than $2/3$ of the MSE height for a short distance. However, application of these guidelines will result in MSE reinforcements not less than 10 ft (3 m) long at the top of the MSE wall (5 ft (1.5 m) minimum *plus* 5 ft (1.5 m) minimum).



(a)

$L_b = \text{Greater of } 0.3H \text{ or } 5 \text{ ft}$

$1 \text{ m} = 3.28 \text{ ft}$

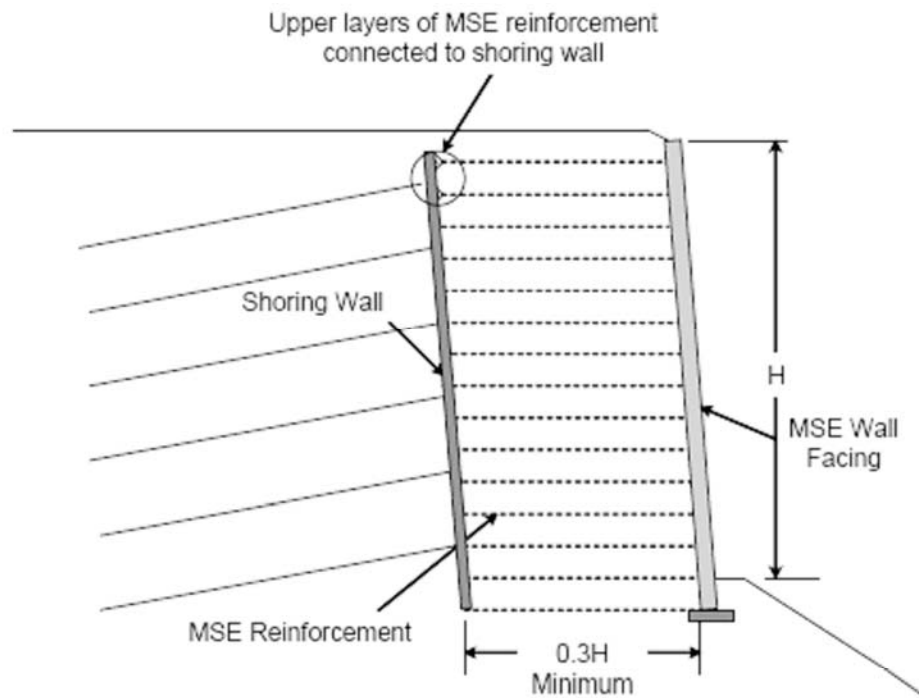

(b)

$L_b = \text{Greater of } 0.3H \text{ or } 5 \text{ ft}$

Figure 6-11. Minimum recommended geometry of a shored MSE wall system in steep terrains, (a) with extension of upper two rows of reinforcement, and (b) with the upper two rows connected to the shoring wall (Morrison et al., 2006).

- Where the shoring wall is less than 2/3 of the height of the MSE wall, as may occur as the wall ends taper, the engineer should check to assure that reinforcement lengths in the upper part of the MSE mass is greater than the conventional 0.7H as discussed in Chapter 4. Generally, this will be satisfied, as long as the total retaining wall height in such sections is less than about 14 ft (4 m).
- If extension of the upper reinforcements is not feasible, a positive mechanical connection between the upper two or more reinforcements and the shoring wall is recommended as shown in Figure 6-11b. Incorporation of interface connections may limit differential movement between the shoring wall and MSE wall components, as a result limiting development of a tension crack, especially if the slack in the MSE reinforcements can be effectively removed. This could potentially be accomplished through the fastening mechanism or by surcharge loading. **Extension of the upper MSE reinforcements is considered superior to mechanical connection of the reinforcements and is recommended by the authors.**
- The critical failure surfaces for SMSE walls with extensible and inextensible reinforcements are presented in Figure 6-12. The critical failure surface is approximated using Rankine's active earth pressure theory within the reinforced soil mass, assuming that the remaining portion lies along the shoring/MSE interface. The critical failure surfaces are consistent with those presented in Chapter 4 (except pullout calculations). Design for internal stability conservatively neglects the additional retaining benefits provided by longer upper reinforcement layers shown in Figure 6-10a or the resistance from connections shown in Figure 6-11b.
- For SMSE walls, lateral pressures are essentially the result of reaction of reinforced soil mass against the shoring wall, and are thus internal to the MSE mass. At each reinforcement level, the horizontal stress, σ_h , along the potential failure line is computed using exactly the procedures in Chapter 4. If superimposed concentrated vertical loads are present then the increment of vertical stress ($\Delta\sigma_v$) maybe computed by a modified version of the 2:1 method as shown in Figure 6-13.

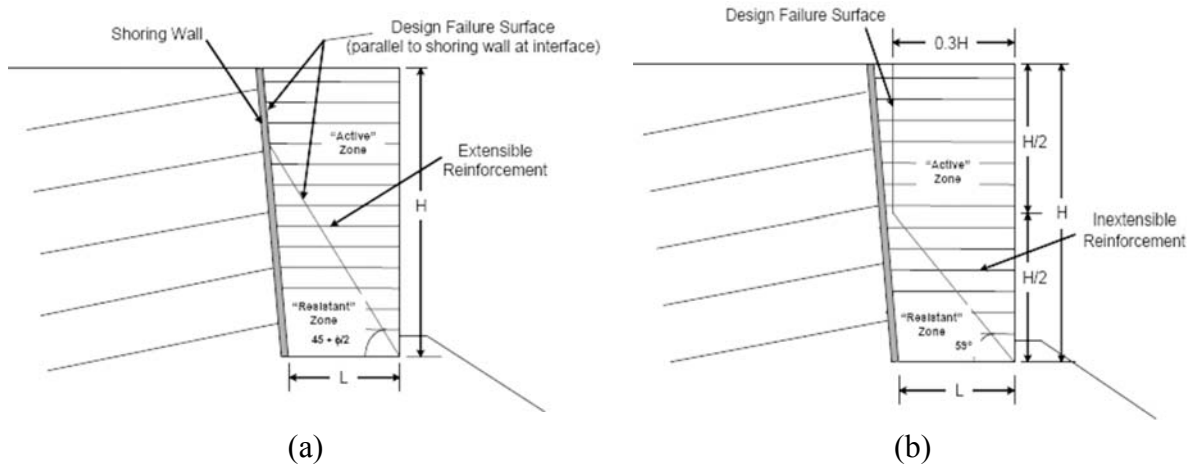
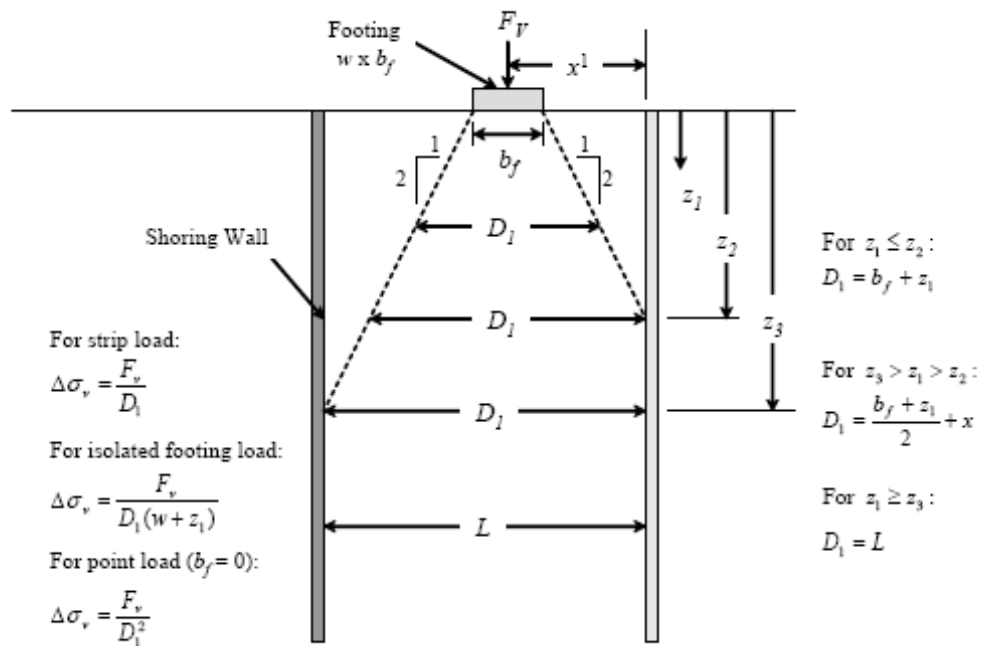

Figure 6-12. Location of potential failure surface for internal stability design of shored MSE walls (a) extensible reinforcements, (b) inextensible reinforcements (Morrison et al., 2006).



Notes:

1. The measurement of x may be from either the face of the MSE wall or the shoring wall, depending on the location of the load footing and the slopes of the various walls.
2. The figure is applicable to MSE walls constructed without a batter, and where the load footing does not straddle the shoring wall. When wall batters are employed, as is generally recommended, the vertical stresses can be estimated by geometrically calculating D_1 at each reinforcement depth. In the case where the footing straddles the shoring wall, D_1 is always greater than z_2 , as defined in the figure.

Figure 6-13. Distribution of stress from concentrated vertical load for internal and external stability calculations (Morrison et al., 2006).

- Internal design differs from design of a conventional MSE wall with regard to pullout of the reinforcements. Conventional MSE design requires that each layer of reinforcement resist pullout by extending beyond the estimated failure surface as indicated in Chapter 4. In the case of a SMSE wall system, only the lower reinforcement layers (i.e., those that extend into the resistant zone) are designed to resist pullout for the entire “active” MSE mass. The relevant equations of T_{MAX} and pullout resistance are given in Figure 6-14. The tensile resistance of the reinforcement as well as the connection strength is evaluated in accordance with the procedures in Chapter 4.
- External stability design of the MSE component of a SMSE wall should address bearing capacity and settlement of foundation materials based strength limit state and service limit state considerations. Limiting eccentricity (i.e., overturning) and sliding are not included as failure mechanisms due to stabilization provided by the shoring wall. Hydrostatic forces are eliminated by incorporating internal drainage into the design. Procedures for evaluating bearing capacity and settlement analysis are the same as those in Chapter 4.
- As part of the design of the individual MSE wall and shoring components, stability internal to these individual components will have been achieved. However, a global stability evaluation of the SMSE wall system as a compound structure must also be evaluated. Various failure modes are shown in Figure 6-15. Although, all failure five failure modes shown in Figure 6-15 must be evaluated, the most critical failure mechanisms are along the shoring/MSE interface (Mode 4 in Figure 6-15) and global stability external to the SMSE wall system must be evaluated (Mode 1 in Figure 6-15). Morrison et al. (2006) present suggestions for global stability analyses and measures to improve stability. Stability analyses for the SMSE wall system should use conventional (i.e., ASD) limit equilibrium analysis methods. As with any earth stability evaluation, selection of appropriate material parameters is of utmost importance in obtaining a realistic evaluation. In addition, the compound nature of the SMSE wall system requires defining other factors such as drainage issues which affect its behavior.

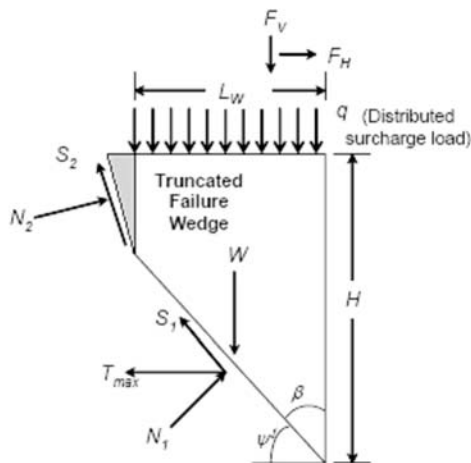

Notes:

1. For extensible reinforcements, $\psi = 45 + \phi/2$; for inextensible reinforcements, $\psi = 59$ degrees.
2. Assume tension crack development and neglect forces N_2 and S_2 .
3. Assume upper wedge (shown as gray) is in equilibrium.

Case 1: For $L_w < H \tan \beta$

$$T_{\max} = \frac{L_w \left[\gamma \left(H - \frac{L_w}{2 \tan \beta} \right) + q \right] + F_V}{\tan(\phi' + \beta)} + F_H$$

Case 2: For $L_w = 0.3H$

$$T_{\max} = \frac{3H \left[\gamma \left(H - \frac{3H}{20 \tan \beta} \right) + q \right] + F_V}{10 \tan(\phi' + \beta)} + F_H$$

Case 3: For $L_w \geq H \tan \beta$

$$T_{\max} = \frac{H \tan \beta (\gamma H + 2q) + 2F_V}{2 \tan(\phi' + \beta)} + F_H$$

Notes:

1. The loads F_V , F_H and W should be multiplied by the appropriate load factors when evaluating the strength and service limit state load combinations.
2. The pullout resistance of the MSE wall component of a SMSE wall system is considered adequate if $T_{\max} \leq \phi_p \Sigma F_{p0}$ where ΣF_{p0} is the summation of the pullout resistances from all layers of reinforcement based on the length of the reinforcement beyond the active zone and ϕ_p is the resistance factor as follows:
 - a. $\phi_p = 0.90$ for $L/H > 0.4$
 - b. $\phi_p = 0.65$ for $L/H \leq 0.4$

Figure 6-14. Computation for T_{\max} and evaluation of pullout resistance (after Morrison et al., 2006).

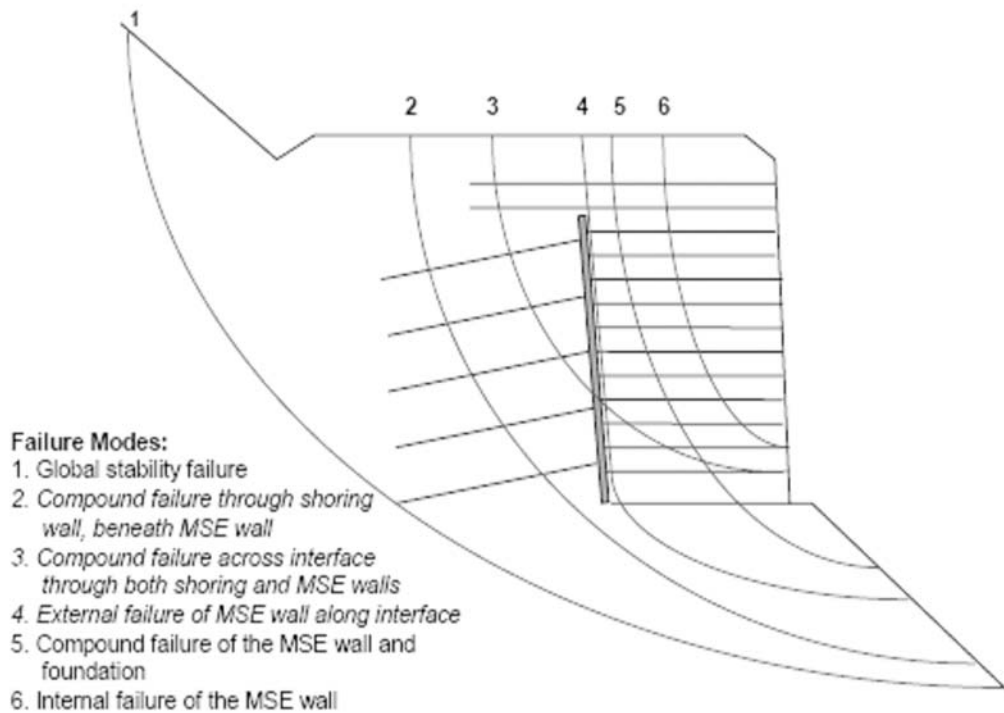

Figure 6-15. Example global stability and compound failure surfaces (Morrison et al., 2006).

6.6 STABLE FEATURE MSE (SFMSE) WALLS

MSE walls can be considered in front of apparently stable features such as a rock face as shown in Figure 6-16. Depending on the space between the MSE wall face and the stable feature, the behavior of the SFMSE wall may be similar to that of a SMSE wall. Following are some guidelines for such cases:

- Establish that the feature behind the proposed SFMSE wall line is stable and will be stable during the design life of the SFMSE wall. The feature should be stabilized to the extent necessary to be compatible with the design life of the SFMSE wall that is being proposed at that particular location.
- Evaluate the deformation and strength behavior of the feature (rock face or existing wall) under additional stresses behind it. Hydrostatic pressure and or other lateral pressures may contribute to the instability of a rock cut in front of which a SFMSE wall is being proposed. The stability analysis should include an evaluation of potential lateral movements under anticipated additional loadings on the existing feature.

- Perform a deformation analysis of the foundation under the SFMSE wall and evaluate the effect of the estimated deformations on the facilities above the top of the wall and in particular at and immediately above the interface between the existing feature and the SFMSE wall.
- Evaluate the effect of the increased stresses at the base of the MSE wall on the settlement of the existing feature. If the existing feature is a retaining wall then it might experience detrimental settlement in the immediate and long-term as well as downdrag forces at the interface between the MSE wall and the existing feature.
- Ensure that the drainage features of the SFMSE wall system and the stable feature behind it are integrated so that there are no lateral pressures due to hydrostatic conditions.
- For SFMSE wall systems, the configuration in Figure 6-16 is recommended wherein at least the top two reinforcements are extended over the top of the stable feature rather than being mechanically connected to the stable feature. For roadway widening projects where the stable feature may be an existing wall, it is recommended that the top of the wall be trimmed as necessary to accommodate the top layers of reinforcements and mitigate long-term maintenance issues.
- Extend all soil reinforcement layers above the top of the stable feature a distance back of L_t , per Figure 6-15, with a minimum of two layers as previously noted.
- Establish the reinforcement layout based on the T_{MAX} values obtained using the guidance provided in Figure 6-14 and other guidance provided in Section 6.5. The minimum clearance between the top of the stable feature and the reinforcement layer above it should be 6 in. (150 mm) to prevent adverse stress concentrations in this area and contact between dissimilar materials.
- Global stability analysis should be performed as the MSE wall will increase driving forces. Global analysis is especially needed where structures are constructed with a slope at the toe or on soft ground. All failure modes similar to those shown in Figure 6-15 should be evaluated.

The above guidelines are valid for static load conditions or in areas where the seismic horizontal accelerations at the foundation level are less than 0.05g. SFMSE walls in seismically active areas should be designed based on a more detailed analysis that includes effects of potential non-uniform distribution of seismic and inertial forces within the wall system (both the MSE and the stable feature components). Finally, these types of walls are not recommended in urban areas for

cases such as roadway widening because of the relatively high risk for tension cracks under dynamic effects of traffic at the interface between the existing feature such as a wall and new MSE wall.

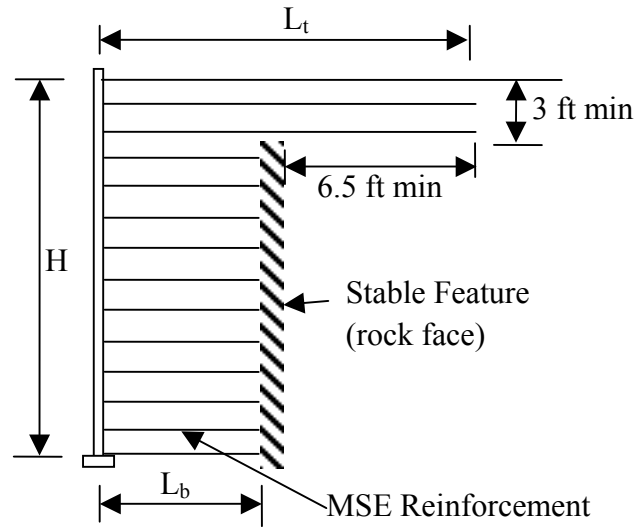

$$1 \text{ m} = 3.28 \text{ ft}$$

$$L_t = 0.8 H \text{ min}; L_b = \text{Greater of } 0.3H \text{ or } 5 \text{ ft}$$

Figure 6-16. Minimum recommended geometry of a stable feature MSE (SFMSE) wall system.

CHAPTER 7

DESIGN OF MSE WALLS FOR EXTREME EVENTS

As per AASHTO (2007) an extreme event is one whose recurrence interval can be thought to exceed design life. AASHTO (2007) has two limit states to deal with such events. These limit states are labeled Extreme Event I and Extreme Event II. In the context of MSE walls, the extreme events with the applicable limit state shown in parentheses that require consideration in the design process are as follows:

- Seismic events (Extreme Event I)
- Vehicular impact events (Extreme Event II)
- Superflood events and scour (Extreme Event II)

This chapter addresses each of the above extreme events along with a review of the applicable limit state, i.e., Extreme Event I or Extreme Event II.

7.1 SEISMIC EVENTS

Seismic events are analyzed under Extreme Event I limit state as per AASHTO (2007¹). Seismic events tend to affect both external and internal stability of MSE walls. Guidance for seismic analysis presented in this section is based on Anderson et al. (2008) and Kavazanjian (2009) and represents updated procedures to those in AASHTO (2007).

7.1.1 External Stability

The external stability uses a displacement based approach. The recommended design methodology is presented in the following steps.

- Step 1** Establish an initial wall design based on static loading using information in Chapters 4, 5 and 6.
- Step 2** Establish the seismic hazard using Article 3.10.2 of AASHTO (2007). Using the 1,000-yr return period seismic hazard maps in AASHTO (2007), estimate the following site-specific values:
- The site peak ground acceleration (PGA), and
 - Spectral acceleration at 1-second, S_1

¹ AASHTO 4th Edition 2007 including 2008 and 2009 Interims. 2008 Interims contain significant seismic revisions.

Step 3 For the project under consideration, establish the Site Effects in accordance with Article 3.10.3 of AASHTO (2007). This includes the determination of Site Class as per Article 3.10.3.1 of AASHTO (2007) and Site Factors, F_{pga} and F_v from Tables 3.10.3.2-1 and 3.10.3.2-3, respectively, of AASHTO (2007). The procedure described herein is applicable to Site Classes A, B, C, D and E. For all sites in Site Class F, site-specific geotechnical investigations and dynamic site response analysis should be performed.

Step 4 Determine the maximum accelerations, k_{max} , and peak ground velocity (PGV) as follows:

$$k_{max} = F_{pga} (PGA) \quad (7-1)$$

$$PGV \text{ (in/sec)} = 38F_v S_1 \quad (7-2)$$

where F_{pga} and F_v are site factors determined in Step 3 and PGA and S_1 are site peak ground acceleration and spectral acceleration at the 1-second period, respectively, as obtained in Step 2.

Step 5 Using a wall height dependent reduction factor, α , obtain an average peak ground acceleration, k_{av} , within the reinforced soil zone as follows:

$$k_{av} = \alpha k_{max} \quad (7-3)$$

where the value of α is based on the Site Class of the foundation soils as follows:

- For Site Class C, D and E (i.e., soils)

$$\alpha = 1 + 0.01H \left[0.5 \left(\frac{F_v S_1}{k_{max}} \right) - 1 \right] \quad (7-4)$$

where H is the wall height in feet at the wall face as shown in Figure 7-1.

- For Site Class A and B foundation conditions (i.e., hard and soft rock), the values of α determined by Equation 7-4 should be increased by 20 percent.

For practical purposes, walls less than approximately 20 ft in height and on very firm ground conditions (i.e., Site Class B or C), $k_{av} \approx k_{max}$. For wall heights greater than 100 ft, site-specific geotechnical investigations and dynamic site response analysis should be performed.

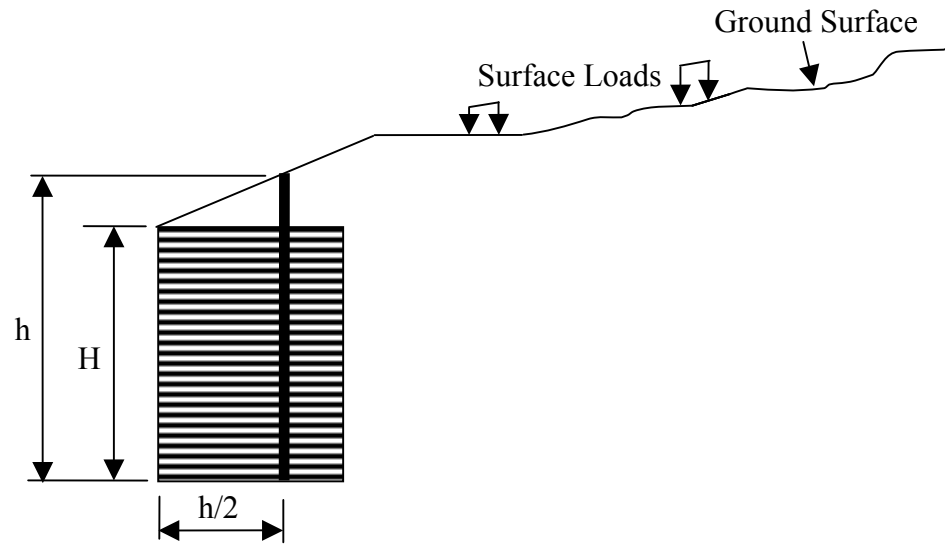

$$h = H + \frac{\tan I(0.5H)}{(1 - 0.5 \tan I)} ; \text{ where } I \text{ is the backfill slope angle}$$

$h/2$ is measured from back of wall facing

Figure 7-1. Definition of heights for seismic analyses.

Step 6 Determine the total (static + dynamic) thrust P_{AE} using one of the following two methods:

Method 1: Mononobe-Okabe (M-O) formulation

$$P_{AE} = 0.5(K_{AE})\gamma_b h^2 \quad (7-5)$$

where h is the wall height along the vertical plane within the reinforced soil mass as shown in Figure 7-1, γ_b is the unit weight of the retained fill and K_{AE} is obtained as follows:

$$K_{AE} = \frac{\cos^2(\phi'_b - \xi - 90 + \theta)}{\cos \xi \cos^2(90 - \theta) \cos(\delta + 90 - \theta + \xi) \left[1 + \sqrt{\frac{\sin(\phi'_b + \delta) \sin(\phi'_b - \xi - I)}{\cos(\delta + 90 - \theta + \xi) \cos(I - 90 + \theta)}} \right]^2} \quad (7-6)$$

where,

$$\xi = \tan^{-1} \left(\frac{k_h}{1 - k_v} \right) \text{ with } k_h = \text{horizontal seismic coefficient and } k_v = \text{vertical seismic}$$

coefficient

δ = angle of wall friction = lesser of the angle of friction for the reinforced soil mass (ϕ'_r) and the retained backfill (ϕ'_b)

I = the backfill slope angle = β (see Figure 4-3) {Note: use GLE for broken back slopes, see Comment 2 below}

ϕ'_b = angle of internal friction for retained backfill

θ = the slope angle of the face (see Figure 4-5 in Chapter 4)

To use the Mononobe-Okabe formulation, two seismic coefficient, k_h and k_v , must be defined. It is assumed that these coefficients are applied simultaneously and uniformly to all parts of the structure, i.e., to the reinforced and retained fill. Typically, the vertical seismic coefficient, k_v , is assumed to be zero. The horizontal seismic coefficient, k_h is taken to be equal to k_{\max} determined in Step 2.

The total thrust, P_{AE} , calculated as per Equation 7-5 is assumed to act at $h/2$, i.e., mid-height of the vertical plane of height h shown in Figure 7-1. Therefore, the stress due to thrust P_{AE} is assumed to be distributed uniformly over the height h .

Comments on use of M-O formulation:

1. For backfills that are sloped at 3H:1V or steeper, it may not be possible to obtain a solution for a certain combination of variables in the M-O formulation. This is because the term $\sin(\phi - \xi - I)$ in Equation 7-6 may become negative and represents a limiting condition since at $I = \phi - \xi$ an unstable slope condition occurs (i.e., FS=1 wherein the failure surface coincides with the slope surface. As the limiting condition is approached the earth pressures based on M-O formulation become unrealistically large.
2. M-O formulation is strictly applicable to homogeneous cohesionless soils and may not yield realistic solutions for more complex cases involving (a) soils which derive their shear strength from both cohesion and friction, i.e., $c-\phi$ soils, (b) non-uniform backslope profiles, and (c) complex surface loadings.

For the cases where M-O formulation leads to unrealistic results, it is recommended that numerical procedures using the same principles of M-O formulation may be used, such as the well-known graphical Culmann method or Coulomb's trial wedge method. However, the more versatile approach for such cases is to utilize the conventional slope stability programs as described in Method 2.

Method 2: Generalized Limit Equilibrium (GLE) slope stability

- a. Define the wall geometry, nominal surface loadings (i.e., loadings with load factor = 1.0), groundwater profile, and design soil properties. The plane where the earth pressure needs to be calculated should be modeled as a free boundary. This boundary is a vertical plane located at a distance of $h/2$ from the back of the wall facing as shown in Figure 7-2.
- b. Choose an appropriate slope stability analysis method. Spencer's method generally yields good results because it satisfies the equilibrium of forces and moments.
- c. Choose an appropriate sliding surface search scheme, e.g., circular, linear, bi-linear, block, etc.
- d. For seismic analysis, use $k_h = k_{av}$ and $k_v = 0$.
- e. Apply the earth pressure as a boundary force, P_{AE} , on the face of vertical plane of height h as shown in Figure 7-2. The angle of the applied force with respect to horizontal depends on assumed friction angle between the wall and soil which is lesser of the angle of friction for the reinforced soil mass (ϕ'_r) and the retained backfill (ϕ'_b). Different application points between $h/3$ and $2h/3$ from the base need to be examined to determine the maximum value of P_{AE} . Change the magnitude of the applied load until a capacity:demand ratio (CDR) of 1.0 is obtained i.e., the load and the resistance are balanced. Thus, the force corresponding to a CDR of 1.0 is equal to the total thrust on the retaining structure.
- f. Verify design assumptions and material properties by examining the loads on individual slices in the output.
- g. Once the maximum value of total thrust, P_{AE} , is determined, apply the force at mid height ($h/2$) as shown in Figure 7-2 for analysis in following steps.

Step 7. Determine the horizontal inertial force, P_{IR} , of the total reinforced wall mass as follows:

$$P_{IR} = 0.5(k_{av})(W) \quad (7-7)$$

where W is the weight of the full reinforced soil mass and any overlying permanent slopes and/or permanent surcharges within the limits of the reinforced soil mass. The inertial force is assumed to act at the centroid of the mass used to determine the weight W .

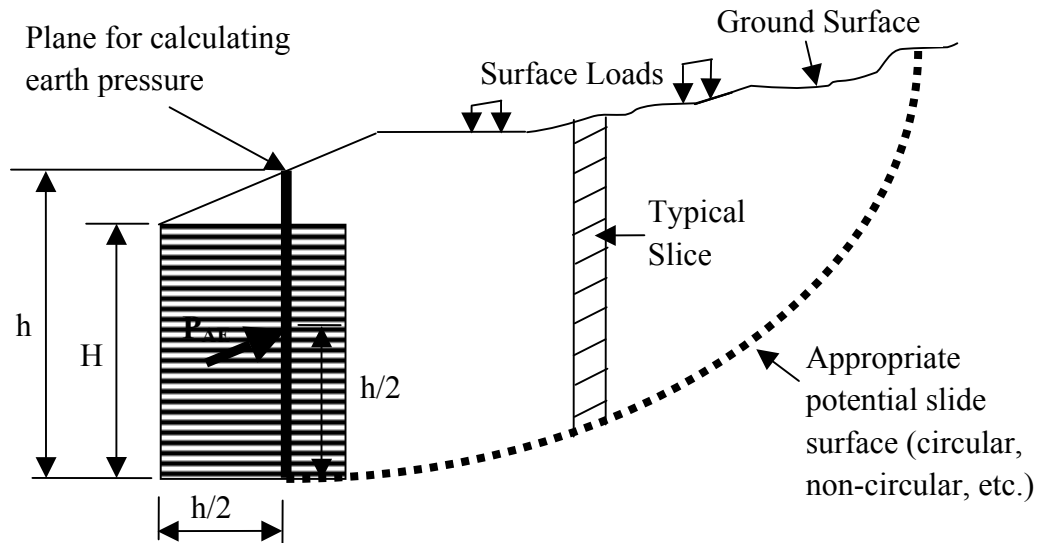

Figure 7-2. Use of a slope stability approach to compute seismic earth pressure.

Step 8 Check the sliding stability using a resistance factor, ϕ_{τ} , equal to 1.0 and the full, nominal weight of the reinforced zone and any overlying permanent surcharges. If the sliding stability is met, the design is satisfactory and go to Step 11. If not, go to Step 9.

Compute the total horizontal force, T_{HF} , is as follows:

- For M-O method:

$$T_{HF} = \text{Horizontal component of } P_{AE}(\cos \delta) + P_{IR} + \gamma_{EQ}(q_{LS})K_{AE}H + \text{other horizontal nominal forces due to surcharges (with load factor =1.0)}$$

where, γ_{EQ} is the load factor for live load in Extreme Event I limit state and q_{LL} is the intensity of the live load surcharge.

- For GLE method:

$$T_{HF} = \text{Horizontal component of } P_{AE} \text{ (since all surcharges are included in the slope stability analysis)} + P_{IR}$$

Compute the sliding resistance, R_{τ} , as follows:

$$R_{\tau} = \Sigma V (\mu)$$

where μ is the minimum of $\tan\phi'_r$, $\tan\phi'_f$ or (for continuous reinforcement) $\tan\phi$ as discussed in Section 4.5.6.a and ΣV is the summation of the vertical forces as follows:

$$\Sigma V = W + P_{AE}\sin\delta + \text{permanent nominal surcharge loads within the limits of the reinforced soil mass}$$

The sliding stability capacity to demand ratio (CDR) is calculated as follows:

$$CDR_{\text{sliding}} = R_{\tau} / T_{HF}$$

If $CDR_{\text{sliding}} > 1$, the design is satisfactory and go to Step 11 otherwise go to Step 9.

Step 9 Determine the wall yield seismic coefficient, k_y , where wall sliding is initiated. This coefficient is obtained by iterative analysis as follows:

- Determine values of P_{AE} as a function of the seismic coefficient k ($< k_{\text{max}}$) as shown in Figure 7-3a.
- Determine horizontal driving and resisting forces as a function of k (using spreadsheet calculations) and plot as a function of k as shown in Figure 7-3b. The value of k_y corresponds to the point where the two forces are equal, i.e., the CDR against sliding equals 1.0.

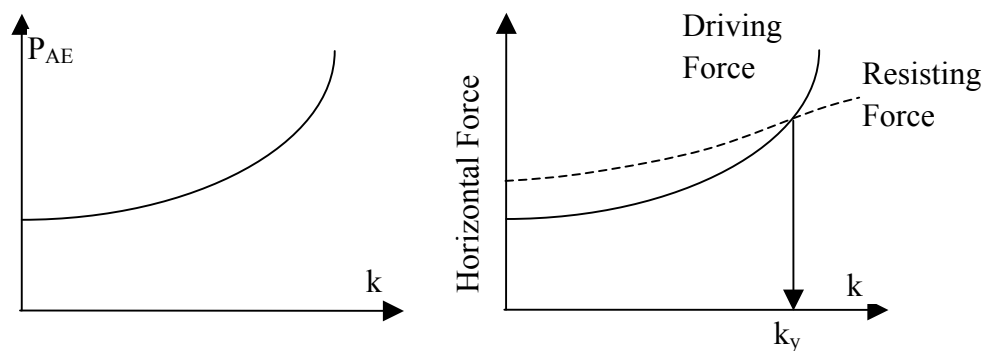

Figure 7-3. Procedure for determination of k_y (Anderson et al., 2008).

Step 10 Determine the wall sliding displacement, d , in inches based on the following relationships between d , k_y/k_{max} , k_{max} , and PGV based on whether the site is located in Western United States (WUS) or Central and Eastern United States (CEUS) as per Figure 7-4:

- For WUS soil and rock sites and CEUS soil sites

$$\log(d) = -1.51 - 0.74\log(k_y/k_{max}) + 3.27\log(1 - k_y/k_{max}) - 0.80\log(k_{max}) + 1.59\log(\text{PGV}) \quad (7-8)$$

- For CEUS rock sites

$$\log(d) = -1.31 - 0.93\log(k_y/k_{max}) + 4.52\log(1 - k_y/k_{max}) - 0.46 \log(k_{max}) + 1.12\log(\text{PGV}) \quad (7-9)$$

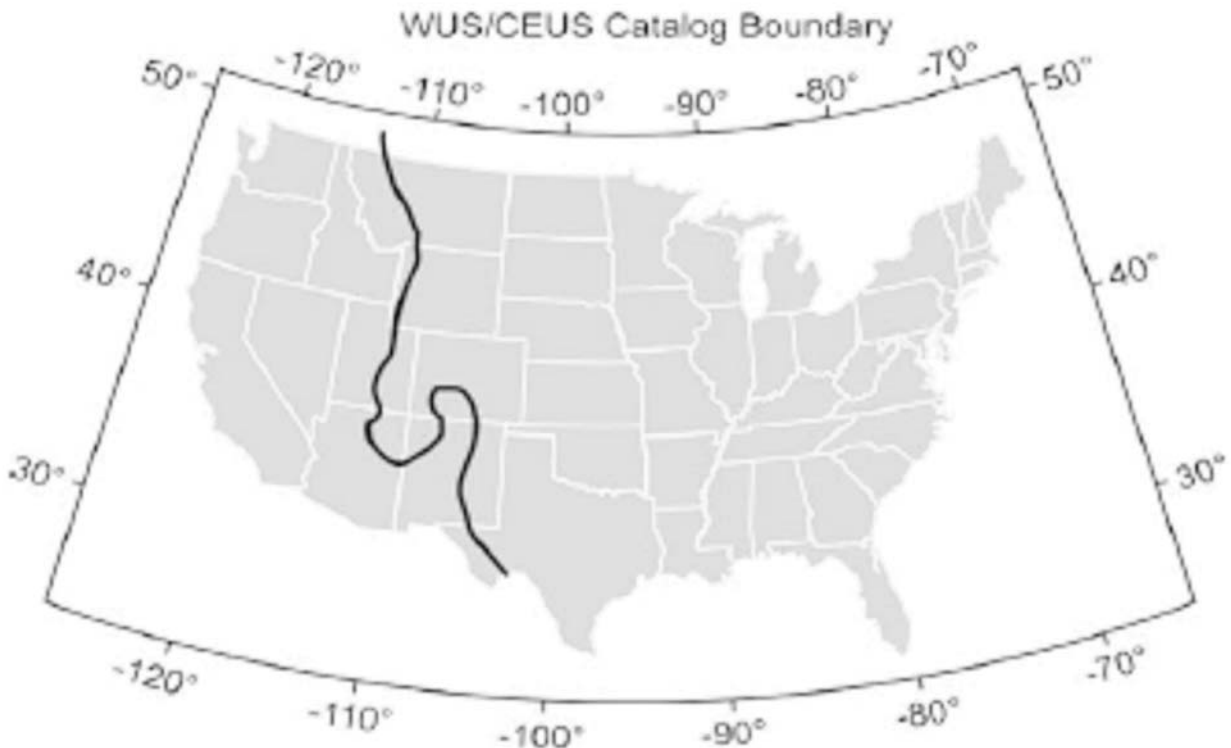

Figure 7-4. Boundary between WUS and CEUS (Anderson et al. 2008).

Step 11 Evaluate the limiting eccentricity and bearing resistance using the same principles discussed in Chapter 4. Include all applicable loads for Extreme Event I. If M-O method is used then add other applicable forces to P_{AE} . If GLE method is used then no additional forces need to be added to P_{AE} since the slope stability analysis includes all applicable forces. Check the limit states using the following criteria:

1. For limiting eccentricity, for foundations on soil and rock, the location of the resultant of the applicable forces should be within the middle two-thirds of the wall base for $\gamma_{EQ} = 0.0$ and within the middle eight-tenths of the wall base for $\gamma_{EQ} = 1.0$. Interpolate linearly between these values as appropriate.
2. For bearing resistance compare the effective uniform bearing pressure to the nominal bearing resistance that is based on the full width of the reinforced zone. A resistance factor of 1.0 is used per Article 10.5.5.3.3 (AASHTO, 2007).

Step 12 If Step 11 criteria are not met, adjust the wall geometry and repeat Steps 6 to 11 as needed.

Step 13 If Step 11 criteria are met, assess acceptability of sliding displacement, d . The amount of displacement which is tolerable will depend on the nature of the wall and what it supports, as well as what is in front of the wall. Typical practice is to limit the lateral displacement in the range of 2.0 in. (50 mm) to 4.0 in (100 mm) assuming that structures on top or at toe of the wall can tolerate such displacements.

7.1.2 Internal Stability

For internal stability, the active wedge is assumed to develop an internal dynamic force, P_i , that is equal to the product of the mass in the active zone and the wall height dependent average seismic coefficient, k_{av} . Thus, P_i is expressed as follows:

$$P_i = k_{av} W_a \quad (7-10)$$

where W_a is the soil weight of the active zone as shown by shaded area in Figure 7-5 and k_{av} given by Equation 7-3. The force P_i is assumed to act as shown in Figure 7-5. If the weight of the facing is significant then include it in W_a computation.

The supplementary inertial force, P_i , will lead to dynamic increases in the maximum tensile forces in the reinforcements. Reinforcements should be designed to withstand horizontal forces generated by the internal inertia force, P_i , in addition to the static forces. During the internal stability evaluation, it is assumed that the location and the maximum tensile force lines do not change during seismic loading.

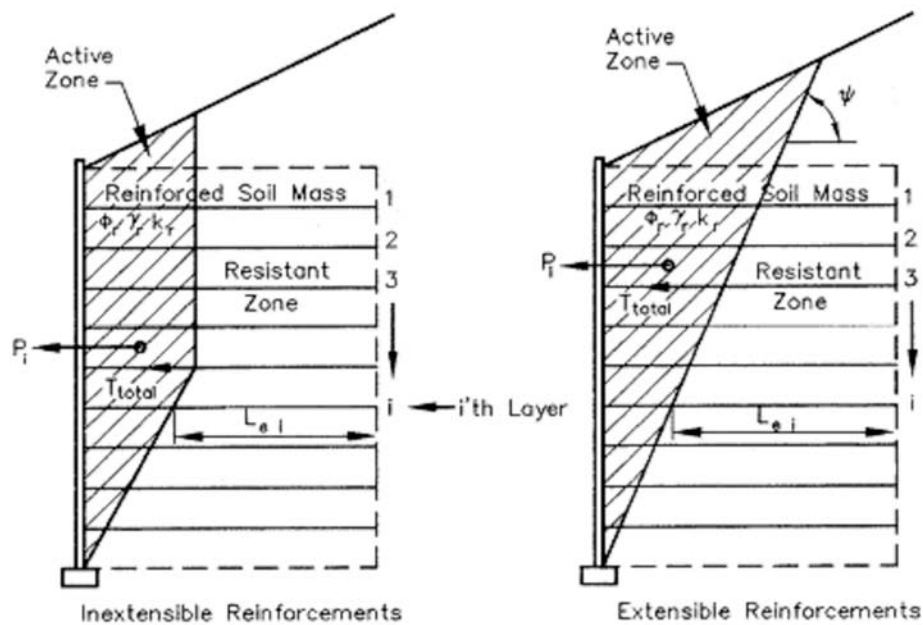

Figure 7-5. Seismic internal stability of a MSE wall.

The inertial force is distributed to the reinforcements equally as follows:

$$T_{md} = \frac{P_i}{n} \quad (7-11)$$

where:

- T_{md} = factored incremental dynamic inertia force at layer i
- P_i = internal inertia force due to the weight of backfill within the active zone, i.e., the shaded area in Figure 7-5
- n = number of soil reinforcement layers within the reinforced soil zone,

The load factor for seismic forces is equal to 1.0. Therefore, the total factored load applied to the reinforcement on a load per unit of wall width basis is determined as follows:

$$T_{total} = T_{max} + T_{md} \quad (7-12)$$

where T_{max} is the factored static load applied to the reinforcements determined using the appropriate equations in Chapters 4 and 6. The reinforcement must be designed to resist the dynamic component of the load at any time during its design life. This includes consideration of both tensile and pullout failures as discussed next.

7.1.2.a Tensile Failure

Design for static loads requires the strength of the reinforcement at the end of the design life to be reduced to account for corrosion for metallic reinforcement, and for creep and other degradation mechanisms for geosynthetic reinforcements. The adjustment for metallic corrosion losses are exactly the same described in Chapter 4 for static analysis. For metallic reinforcements, use the following resistance factors while evaluating tensile failure under combined static and earthquake loading (per Table 11.5.6-1 of AASHTO {2007}):

- Strip reinforcements: 1.00
- Grid reinforcements: 0.85

In contrast, the procedures for geosynthetic do not require a creep reduction for the short duration seismic loading condition and only reductions for geosynthetic degradation losses are required. Strength loss in geosynthetics due to creep requires long-term, sustained loading. The dynamic component of load for seismic design is a transient load and does not cause strength loss due to creep. Therefore, the resistance of the reinforcement to the static component of load, T_{max} , must be handled separately from the dynamic component of load, T_{md} . The strength required to resist T_{max} must include the effects of creep, but the strength required to resist T_{md} should not include the effects of creep. Thus, for geosynthetic reinforcement rupture, the reinforcement is designed to resist the static and dynamic components of the load determined as follows:

For the static component:

$$S_{rs} \geq \frac{T_{max} RF}{\phi R_c} \quad (7-13)$$

For the dynamic component:

$$S_{rt} \geq \frac{T_{md} RF_{ID} RF_D}{\phi R_c} \quad (7-14)$$

where:

- ϕ = resistance factor for combined static/earthquake loading = 1.20 from Table 11.5.6-1 of AASHTO (2007)
- S_{rs} = ultimate reinforcement tensile resistance required to resist static load component
- S_{rt} = ultimate reinforcement tensile resistance required to resist dynamic load component
- R_c = reinforcement coverage ratio

- RF = combined strength reduction factor to account for potential long-term degradation due to installation damage, creep, and chemical aging, equal to $RF_{CR} \times RF_{ID} \times RF_D$ (see Chapter 3)
- RF_{ID} = strength reduction factor to account for installation damage to reinforcement
- RF_D = strength reduction factor to prevent rupture of reinforcement due to chemical and biological degradation

Using the above equations, the required ultimate tensile resistance of the geosynthetic reinforcement is determined as follows:

$$T_{ult} = S_{rs} + S_{rt} \quad (7-15)$$

7.1.2.b Pullout Failure

For pullout of steel or geosynthetic reinforcement, the following equation is used:

$$L_e \geq \frac{T_{total}}{\phi(0.8F^* \alpha \sigma_v CR_c)} \quad (7-16)$$

where:

- L_e = length of reinforcement in resisting zone
- T_{total} = maximum factored reinforcement tension from Equation 7-12
- ϕ = resistance factor for reinforcement pullout = 1.20 from Table 11.5.6-1 of AASHTO (2007)
- F^* = pullout friction factor
- α = scale effect correction factor
- σ_v = unfactored vertical stress at the reinforcement level in the resistant zone
- C = overall reinforcement surface area geometry factor
- R_c = reinforcement coverage ratio

For seismic loading conditions, the value of F^* , the pullout resistance factor, is reduced to 80 percent of the value used for static design, unless dynamic pullout tests are performed to directly determine the F^* value.

7.1.3 Facing Reinforcement Connections

Facing elements are designed to resist the total (static + seismic) factored load, i.e., T_{total} . Facing elements should be designed in accordance with applicable provisions of Sections, 5, 6, and 8 of AASHTO (2007) for reinforced concrete, steel, and timber, respectively.

For segmental concrete block faced walls, the blocks located above the uppermost reinforcement layer should be designed to resist toppling failure during seismic loading.

For geosynthetic connections subjected to seismic loading, the factored long-term connection strength, ϕT_{ac} , must be greater than T_{total} (i.e., $T_{max} + T_{md}$). If the connection strength is partially or fully dependent on friction between the facing blocks and the reinforcement (e.g., MBW facing), the connection strength to resist seismic loads should be reduced to 80 percent of its static value as follows:

For the static component of the load:

$$S_{rs} \geq \frac{T_{max} RF_D}{0.8 \phi (CR_{cr}) R_c} \quad (7-17)$$

For the dynamic component of the load:

$$S_{rt} \geq \frac{T_{md} RF_D}{0.8 \phi (CR_u) R_c} \quad (7-18)$$

where:

- S_{rs} = ultimate reinforcement tensile resistance required to resist static load component
- T_{max} = applied load to reinforcement
- RF_D = reduction factor to prevent rupture of reinforcement due to chemical and biological degradation from Chapter 3
- ϕ = resistance factor = 1.20 applied to both the static and the dynamic components, from Table 11.5.6.4-1 of AASHTO (2007)
- CR_{cr} = long-term connection strength reduction factor to account for reduced ultimate strength resulting from connection
- R_c = reinforcement coverage ratio
- S_{rt} = ultimate reinforcement tensile resistance required to resist dynamic load component
- T_{md} = factored incremental dynamic inertia force
- CR_u = short-term reduction factor to account for reduced ultimate strength resulting from connection.

For mechanical connections that do not rely on a frictional component, the 0.8 multiplier is removed from Equations 7-17 and 7-18.

The required ultimate tensile resistance of the geosynthetic reinforcement at the connection is:

$$T_{\text{ult-conn}} = S_{rs} + S_{rt} \quad (7-19)$$

The connection capacity of a facing/reinforcement connection system that is fully dependent on the shear resisting devices for the connection capacity will not be significantly influenced by the normal stress between facing blocks. The percentage of connection load carried by the shear resisting devices relative to the frictional resistance to meet the specification requirements should be determined based on past successful performance of the connection system.

For cases where seismic analysis is required as per Section 4 of AASHTO, facing connections in MBW unit faced walls should use shear resisting devices between the facing blocks and soil reinforcement such as shear keys and structural pins (i.e., pins manufactured from material meeting the design life of the structure, e.g., steel and HDPE) and should not be fully dependent on frictional resistance between the soil reinforcement and facing blocks.

For steel reinforcement connections, AASHTO (2007) recommends that the resistance factors for combined static and seismic loads as follows:

- Strip reinforcements: 1.00
- Grid reinforcements: 0.85

7.2 VEHICULAR IMPACT EVENTS

Traffic railing impact loads are analyzed under Extreme Event II limit state as per Article A13.2 (AASHTO, 2007). Traffic railing impact events tend to affect only the internal stability of MSE walls. Guidance for traffic barrier analysis presented in this section is based on NCHRP 22-20 (Bligh et al., 2009), which is an extension of the previous FHWA (Elias et al., 2001) method based on laboratory and full-scale field tests. Guidance for post and beam railings is based upon AASHTO (2007).

7.2.1 Traffic Barriers

The impact traffic load on barriers constructed over the front face of MSE walls, must be designed to resist the overturning moment by their own mass per Article 11.10.10.2 (AASHTO, 2007).

Static Impact Load

The recommended static impact force is 10,000 lb (45 kN) applied on a barrier with a minimum height of 32 in. (810 mm) above the roadway. Bligh et al. (2009) found that a 10,000 lbs (45 kN) static impact load is equivalent to a dynamic TL-4 railing test level of 54,000 lb (240 kN), as illustrated in Figure 7-6.

The wall design should ensure that the reinforcement does not rupture or pullout during the impact event. Where the impact barrier moment slab is cast integrally with a concrete pavement, the additional force may be neglected. The recommended static impact forces for rupture and for pullout are based upon the recent NCHRP 22-20 project (Bligh et al., 2009) and past practice.

Load Combination and Load Factors

The load factors and load combination for an Extreme Event II are summarized in Table 4-1. A load factor, $\gamma_{P-EV} = 1.35$ is used for the static soil load. The traffic surcharge, modeled as an equivalent soil height of 2 ft, also uses the load factor $\gamma_{P-EV} = 1.35$ (and not $\gamma = 0.50$), for internal stability analysis. The static equivalent impact loads are multiplied by a load factor, $\gamma_{CT} = 1.00$.

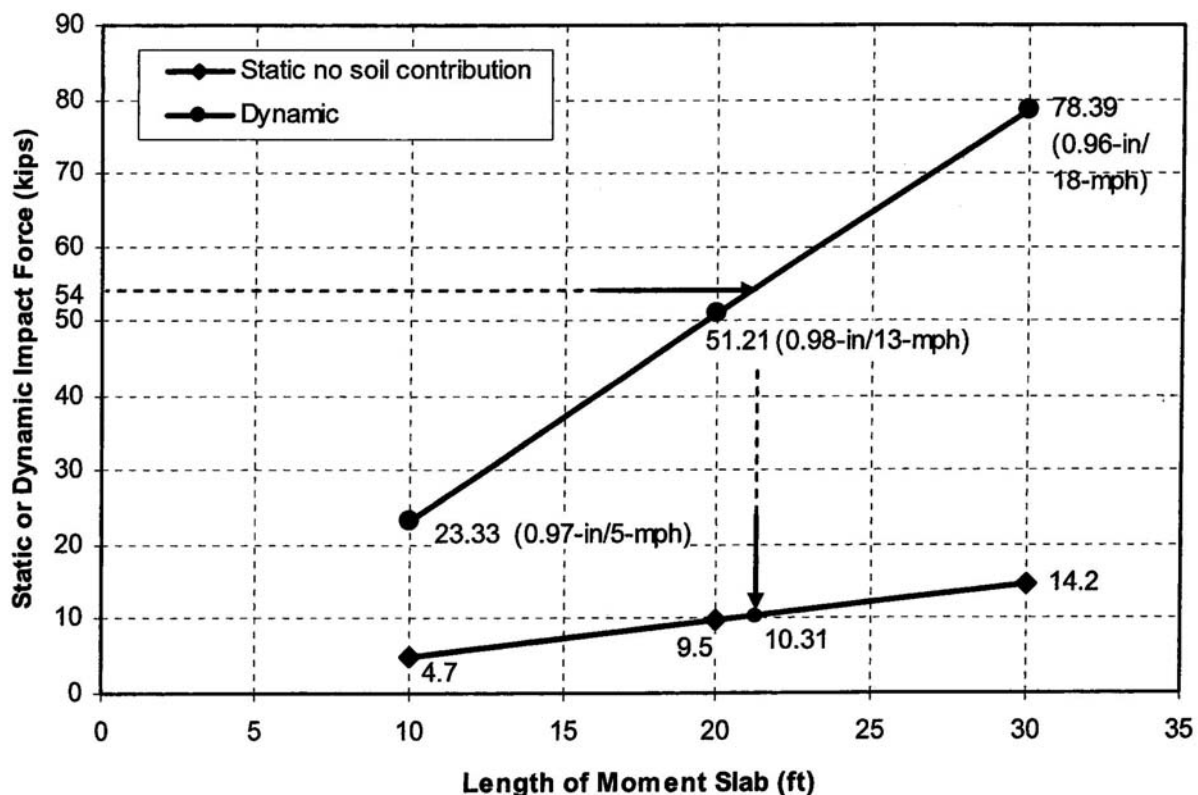

Figure 7-6. Comparison of static and dynamic impact force with 1-inch (25 mm) maximum displacement (Bligh et al., 2009). (1 kip = 4.44 kN; 1 ft = 0.3 m)

Reinforcement Rupture

The static impact force, adds an additional horizontal force to the upper 2 layers of soil reinforcement. It is recommended that the upper layer of soil reinforcement be designed for a rupture impact load equivalent to a static load of 2,300 lb/ft (33.5 kN/m) of wall; and the second layer be designed with a rupture impact load equivalent to a static load of 600 lb/ft (8.8 kN/m). A distribution of stresses, as discussed in Article 11.101.10.2 and illustrated in Figure 3.11.6.3-2 (AASHTO, 2007), is not recommended.

The load factor for impact is equal to 1.0. Therefore, the total factored load applied to the reinforcement on a load per unit of wall width basis is determined as follows:

$$T_{\text{total}} = T_{\text{max}} + T_I \quad (7-20a)$$

where:

T_I = factored impact load at layer 1 or 2, respectively

T_{MAX} = reinforcement tension from static earth and traffic loads

With terms defined, this equation is:

$$T_{\text{total}} = S_V K_r \gamma_r [(Z + h_{\text{eq}}) \gamma_{\text{EV-MAX}}] + t_i (\gamma_{\text{CT}}) \quad (7-20b)$$

where:

t_i = equivalent static load for impact load at layer i , ($t_1 = 2,300$ lb/ft and $t_2 = 600$ lb/ft) and other terms as previously defined (Chapter 4 and/or 7).

An example calculation is presented in Appendix E.6. Note that for geosynthetic reinforcements, the nominal strength used to structurally size the reinforcements to resist the impact load is not increased by eliminating the reduction factor for creep, as was done for internal seismic design in Section 7.2.1. This is recommended because full-scale traffic barrier impact testing with geosynthetic soil reinforcement has not been performed to date.

Reinforcement Pullout

The pullout resistance of the soil reinforcement to the impact load is resisted over the full-length of the reinforcements (i.e., L). The traffic surcharge, modeled as an equivalent soil height of 2 ft, is included in the nominal vertical stress, σ_v , for pullout resistance calculation. Pullout is resisted over a greater length of wall than the reinforcement rupture loads. Therefore, for pullout, it is recommended that the upper layer of soil reinforcement be designed for a pullout impact load

equivalent to a static load of 1,300 lb/ft (19.0 kN/m) of wall; and the second layer be designed with a pullout impact load equivalent to a static load of 600 lb/ft (8.8 kN/m).

Resistance Factors for Tensile and Pullout Resistance

The resistance factors presented in Table 4-7 for “Combined static/traffic barrier impact” are recommended for Extreme Event II impact loading. (Note that AASHTO does not specifically address tensile resistance factors for impact loading.) The tensile and connection rupture resistance factors are a function of the type of reinforcement.

A pullout resistance factor of 1.00 is recommended for metallic and geosynthetic reinforcements. (Note that AASHTO does not specifically address pullout resistance factors for impact loading.)

Barrier, Coping, and Moment Slab Design

Example traffic barriers are illustrated in Figure 5-2. Typically, the base slab length is 20 ft (6 m) and jointed to adjacent slabs with shear dowels. Parapet reinforcement shall be designed in accordance with AASHTO Section 13 Railings. See NCHRP 22-20 report (Bligh et al., 2009) for barrier, coping, and moment loading recommendations. The anchoring slab shall be strong enough to resist the ultimate strength of the standard parapet, and sized to provide adequate resistance to sliding and overturning.

MSE Facing Panel Design

The upper facing panel must be separated from the barrier slab with 1 to 2 in. (25 to 50 mm) of expanded polystyrene (see Figure 5-2(b)). The distance should be adequate to allow the barrier and slab to resist the impact load in sliding and overturning without loading the facing panel. Separation between the precast facing and cast-in-place resistance slab is required to prevent stressing on the facing panels due to slab curing and shrinking.

7.2.2 Post and Beam Railings

Flexible post and beam barriers, when used, shall be placed at a minimum distance of 3.0 ft (0.9 m) from the wall face, driven 5.0 ft (1.5 m) below grade, and spaced to miss the reinforcements where possible. If the reinforcements cannot be missed, the wall shall be designed accounting for the presence of an obstruction. Each of the upper two rows of reinforcement shall be designed for an additional horizontal load of 150 lb/ft (2.2 kN/m) of wall, for a total additional load of 300 lb/ft (4.4 kN/m).

7.3 SUPERFLOOD EVENTS AND SCOUR

The stability of walls and abutments in areas of turbulent flow must be addressed in design. Wall design should be based on the total scour depths estimated per Article 2.6.4.4.2 (AASHTO, 2007). Scour should be investigated for two flood conditions:

- Design Flood
- Check Flood

The design flood (storm surge, tide, or mixed population flood) is the more severe of the 100-year event or an overtopping flood of lesser recurrence interval. Stability design of the wall should be assessed assuming that the streambed material above the total scour line has been removed. This should be analyzed as a strength limit state.

The check flood (storm surge, tide, or mixed population flood) is the more severe of the 500-year event or an overtopping flood of lesser recurrence interval. Stability design of the wall should be assessed assuming that the streambed material above the total scour line has been removed. This is an extreme event, and the extreme event limit state applies. Resistance factors for this extreme limit state may be taken at 1.0, per Articles 10.6.4 and 10.5.5.3.3 (AASHTO, 2007).